

# COMPENDIUM EMC

*European Mathematical Cup*

2012 - 2025

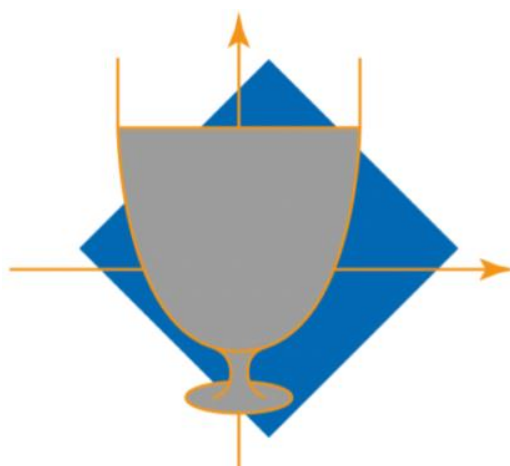

**Gerard Romo Garrido**

Toomates Colección vol. 104



# Toomates Colección

Los libros de **Toomates** son materiales digitales y gratuitos. Son digitales porque están pensados para ser consultados mediante un ordenador, tablet o móvil. Son gratuitos porque se ofrecen a la comunidad educativa sin coste alguno. Los libros de texto pueden ser digitales o en papel, gratuitos o en venta, y ninguna de estas opciones es necesariamente mejor o peor que las otras. Es más: Suele suceder que los mejores docentes son los que piden a sus alumnos la compra de un libro de texto en papel, esto es un hecho. Lo que no es aceptable, por inmoral y mezquino, es el modelo de las llamadas "licencias digitales", "licencias de uso" y en general cualquier forma de "pago por el acceso a los materiales didácticos", con las que algunas empresas pretenden cobrar a los estudiantes, una y otra vez, por acceder a los mismos contenidos (unos contenidos que, además, son de una bajísima calidad). Este modelo de negocio es miserable, pues impide el compartir un mismo material, incluso entre dos hermanos, pretende convertir a los estudiantes en un mercado cautivo, exige a los estudiantes y a las escuelas costosísimas líneas de Internet, pretende pervertir el conocimiento, que es algo social, público, convirtiéndolo en un producto de propiedad privada, accesible solo a aquellos que se lo puedan permitir, y solo de una manera encapsulada, fragmentada, impidiendo el derecho del alumno de poseer todo el libro, de acceder a todo el libro, de moverse libremente por todo el libro.

Nadie puede pretender ser neutral ante esto: Mirar para otro lado y aceptar el modelo de pago por acceso a los materiales es admitir un mundo más injusto, es participar en la denegación del acceso al conocimiento a aquellos que no disponen de medios económicos, y esto en un mundo en el que las modernas tecnologías actuales permiten, por primera vez en la historia de la Humanidad, poder compartir el conocimiento sin coste alguno, con algo tan simple como es un archivo "pdf". **El conocimiento no es una mercancía.**

El proyecto Toomates tiene como objetivo la promoción y difusión entre el profesorado y el colectivo de estudiantes de unos materiales didácticos libres, gratuitos y de calidad, que fuerce a las empresas comerciales a competir ofreciendo alternativas de pago atractivas aumentando la calidad de los materiales que ofrecen, (que son muy mediocres) y no mediante retorcidas técnicas comerciales.

Estos libros se comparten bajo una licencia "**Creative Commons 4.0 (Attribution Non Commercial)**": Se permite, se promueve y se fomenta cualquier uso, reproducción y edición de todos estos materiales siempre que sea sin ánimo de lucro y se cite su procedencia. Todos los libros se ofrecen en dos versiones: En formato "**pdf**" para una cómoda lectura y en el formato "**doc**" de MSWord para permitir y facilitar su edición y generar versiones parcial o totalmente modificadas. **¡Libérate de la tiranía y mediocridad de los productos comerciales! Crea, utiliza y comparte tus propios materiales didácticos.**

## Problem Solving (en español):

[Geometría Axiomática](#) [Problemas de Geometría Vol. 1](#) [Vol. 2](#) [Vol. 3](#)  
[Introducción a la Geometría](#) [Álgebra](#) [Teoría de números Vol. 1](#) [Vol. 2](#) [Combinatoria](#)  
[Probabilidad](#) [Trigonometría](#) [Desigualdades](#) [Números complejos](#) [Calculus & Precalculus](#)

## Libros de texto para ESO y bachillerato (en español y en catalán):

[Cálculo infinitesimal ESP](#) [CAT](#) [Álgebra Lineal ESP](#) [CAT](#) [Geometría Lineal ESP](#) [CAT](#)  
[Números Complejos ESP](#) [CAT](#) [Combinatoria y probabilidad ESP](#) [CAT](#) [Estadística ESP](#) [CAT](#)  
[Programación Lineal ESP](#) [CAT](#) [Álgebra ESP](#) [CAT](#) [Trigonometría ESP](#) [CAT](#)  
[Geometría analítica ESP](#) [CAT](#) [Funciones ESP](#) [CAT](#) [Números \(Preálgebra\) ESP](#) [CAT](#)  
[Proporcionalidad ESP](#) [CAT](#) [Medidas geométricas ESP](#) [CAT](#) [Mates amb Excel](#)

## PAU españolas, evaluación diagnóstica y pruebas de acceso:

[Cataluña TEC](#) [Cataluña CCSS](#) [Valencia](#) [Galicia](#) [País Vasco](#) [Balears](#)  
[ACM6EP](#) [ACM4](#) [CFGs](#) [PAP](#)

## Reválidas internacionales:

[Portugal](#) [Italia](#) [Francia](#) [Rumanía](#) [Hungría](#) [Polonia](#) [Pearson Edexcel Int A Level](#)  
[China-Gaokao](#) [China-Zhongkao](#) [Corea-Suneung](#) [Israel-Bagrut](#) [Cambridge Int A Level](#)  
[Cambridge IGCSE](#) [AQA GCSE](#) [International Baccalaureate \(IB\)](#) [Pearson Edexcel IGCSE](#)

## Competiciones matemáticas:

Canguro: [España 1 2 3](#) [Cataluña 1 2 3](#) [Francia](#) [Reino Unido](#) [Austria 1 2](#) [USA](#)  
Canguro Style: [AMC USA 8 10 12](#) [CDP](#) [AMC Australia](#) [Arquimede](#)  
USA: [Mathcounts](#) [AIME](#) [USAJMO](#) [USAMO](#) [TSTST](#) [TST](#) [ELMO](#) [Putnam](#) [HMMT](#)  
España: [OME](#) [OMEFL](#) [OMEEX](#) [OMC](#) [OMEA](#) [OMEM](#) [OMA](#) [OFEM](#)  
Europa: [OMI](#) [BMO](#) [BalkanMO](#) [JBMO](#) [OPM](#) [OMP](#) [OMJ](#) [ONM](#) [Baltic Way](#) [RMM](#) [EMC](#)  
Internacional: [IMO](#) [IGO](#) [SMT](#) [INMO](#) [CMO](#) [EGMO](#) [KMO](#) [KJMO](#)  
AHSME: [Book 1](#) [2](#) [3](#) [4](#) [5](#) [6](#) [7](#) [8](#) [9](#)

## Otros materiales:

Pizzazz! ( [Book A](#) [B](#) [C](#) [D](#) [E](#) [Pre-Algebra](#) [Algebra](#) ), [REOIM](#) , [Llibre3r](#) , [Excalibur](#)

¡Genera tus propias versiones de este documento! Siempre que es posible se ofrecen las versiones editables "MS Word" de todos los materiales para facilitar su edición.

¡Ayuda a mejorar! Envía cualquier duda, observación, comentario o sugerencia a [toomates@gmail.com](mailto:toomates@gmail.com)

¡No utilices una versión anticuada! Todos estos libros se revisan y amplían constantemente. Descarga totalmente gratis la última versión de estos documentos en los correspondientes enlaces superiores, en los que siempre encontrarás la versión más actualizada.

Consulta el [catálogo de libros](http://www.toomates.net) completo en <http://www.toomates.net>

¿Problemas para descargar algún documento? Descarga toda la biblioteca Toomates [Aquí](#) 

Visita mi [Canal de Youtube](https://www.youtube.com/c/GerardRomo): <https://www.youtube.com/c/GerardRomo> 

Visita mi [blog](https://toomatesbloc.blogspot.com/): <https://toomatesbloc.blogspot.com/>

## **Presentation.**

The European Mathematical Cup (abbr. EMC) is a high school mathematics competition organized by the Croatian association Young Gifted Mathematicians Marin Getaldić ([www.mnm.hr](http://www.mnm.hr)) in cooperation with various wonderful professors and university students who help us organize the competition internationally. If you are interested in joining as a local organizer, don't hesitate to contact us.

The EMC usually takes place in December, and we try to arrange for all contestants to participate in the competition in their hometown. After the competition, the local organizers send the scans of students' solutions to us for evaluation. They may also evaluate the solutions themselves. The official results are published on the website as soon as possible after all of the papers have been graded.

The EMC is primarily intended for high school students, but we do also welcome exceptional elementary school students who wish to compete. The competition is divided into two categories: Junior (students younger than 17 on the day of the competition and who have never participated at the IMO) and Senior (other high-school students or exceptional elementary school students). A student who satisfies the criteria to compete in the Junior category can choose to compete in the Senior category instead.

The duration of the competition for both categories is 4 hours. Within that time, the students attempt to solve 4 problems, one from each of the following areas: algebra, combinatorics, geometry and number theory. We attempt to sort the problems by difficulty. Modelled by the rules of other international competitions such as the IMO, the only instruments permitted in the competition are the writing and drawing instruments. The use of formulas, calculators and other instruments is prohibited. In terms of required knowledge, the problems are similar to the IMO problems, albeit the problems of the Junior category are usually more elementary and require less knowledge.

# Índice.

			Estadísticas
	Sample	5	
1	2012	17	
2	2013	26	
3	2014	37	
4	2015	49	
5	2016	62	
6	2017	80	
7	2018	96	
8	2019	116	
9	2020	133	153
10	2021	154	172
11	2022	173	196
12	2023	198	209
13	2024	210	226
14	2025	227	244

# 1<sup>st</sup> BALKAN STUDENT MATHEMATICAL COMPETITION

1. Matematičko natjecanje učenika Balkana

November 2008.

2<sup>nd</sup> grade

**Problem 1.** If  $x$ ,  $y$  and  $z$  are positive real numbers for which  $x + y + z = 1$ , prove the inequality

$$\frac{1}{\sqrt{x+y}} + \frac{1}{\sqrt{y+z}} + \frac{1}{\sqrt{z+x}} \leq \frac{1}{\sqrt{2xyz}}.$$

*(Adrian Satja Kurdija)*

**Problem 2.** A natural number is written in each cell of  $10 \times 10$  table. It is known that, no matter which 5 columns and 5 rows of this table we choose, the sum of numbers in their 25 intersection cells is even. Prove that all the numbers in the table are even.

**Problem 3.** Let  $M_n$  and  $N_n$  be points on sides  $\overline{CA}$  and  $\overline{CB}$  of triangle  $ABC$ , respectively, such that

$$|CM_n| = \frac{1}{n} |CA|, \quad |CN_n| = \frac{1}{n+1} |CB|, \quad \forall n \in \mathbb{N}.$$

Find the locus of points  $M_i N_i \cap M_j N_j$ , where  $i$  and  $j$  are different natural number.

**Note.**  $M_i N_i \cap M_j N_j$  denotes the intersection of lines  $M_i N_i$  and  $M_j N_j$ .

**Problem 4.**  $a$ ,  $b$  and  $c$  are natural numbers. It is known that  $a^2 + b^2 + abc$  has no more than 2008 natural divisors and that it is divisible by  $(c+2)^{1004}$ . Prove that  $a$  and  $b$  are not relatively prime.

*(Adrian Satja Kurdija)*

Time allowed: 240 minutes.

Each problem is worth 10 points.

Write each problem on a separate paper.

Calculators or any other helping items, excluding rulers and compasses, are not allowed.

# 1<sup>st</sup> BALKAN STUDENT MATHEMATICAL COMPETITION

1. Matematičko natjecanje učenika Balkana

November 2008.

2<sup>nd</sup> grade

Solutions

**Problem 1.** If  $x$ ,  $y$  and  $z$  are positive real numbers for which  $x + y + z = 1$ , prove the inequality

$$\frac{1}{\sqrt{x+y}} + \frac{1}{\sqrt{y+z}} + \frac{1}{\sqrt{z+x}} \leq \frac{1}{\sqrt{2xyz}}.$$

(Adrian Satja Kurdija)

**Solution.** Multiplying the given inequality by  $2\sqrt{xyz}$ , we get an equivalent inequality

$$2\sqrt{\frac{xyz}{x+y}} + 2\sqrt{\frac{xyz}{y+z}} + 2\sqrt{\frac{xyz}{z+x}} \leq \sqrt{2}.$$

Let us notice that  $\frac{xy}{x+y} \leq \frac{x+y}{4} \iff (x-y)^2 \geq 0$ , so  $\frac{xy}{x+y} \leq \frac{x+y}{4}$ . Now,

$$2\sqrt{\frac{xyz}{x+y}} = 2\sqrt{\frac{xy}{x+y} \cdot z} \leq 2\sqrt{\frac{x+y}{4} \cdot z} = \sqrt{z(x+y)}.$$

(2 points)

Using Arithmetic Mean - Geometric Mean inequality (or using the fact that the square of a real number is always nonnegative) on numbers  $z\sqrt{2}$  and  $\frac{x+y}{\sqrt{2}}$ , we get

$$\sqrt{z(x+y)} = \sqrt{z\sqrt{2} \cdot \frac{x+y}{\sqrt{2}}} \leq \frac{1}{2} \left( z\sqrt{2} + \frac{x+y}{\sqrt{2}} \right) = \frac{(x+y+2z)\sqrt{2}}{4}.$$

(3 points)

With this, we have shown that

$$2\sqrt{\frac{xyz}{x+y}} \leq \frac{(x+y+2z)\sqrt{2}}{4}.$$

Analogously, we show that

$$2\sqrt{\frac{xyz}{y+z}} \leq \frac{(y+z+2x)\sqrt{2}}{4},$$

$$2\sqrt{\frac{xyz}{z+x}} \leq \frac{(z+x+2y)\sqrt{2}}{4}.$$

By adding these three inequalities we get

$$2\sqrt{\frac{xyz}{x+y}} + 2\sqrt{\frac{xyz}{y+z}} + 2\sqrt{\frac{xyz}{z+x}} \leq \frac{(4x+4y+4z)\sqrt{2}}{4} = \sqrt{2}.$$

We have, hence, proven the inequality in question.

(5 points) ■

**Problem 2.** A natural number is written in each cell of  $10 \times 10$  table. It is known that, no matter which 5 columns and 5 rows of this table we choose, the sum of numbers in their 25 intersection cells is even. Prove that all the numbers in the table are even.

**Solution.** Let us first prove the following lemma.

**Lemma 1.** If the sum of each 5 of the given 10 natural numbers is even, then all these numbers are even.

**Proof.** Let's assume the opposite. It is clear that not all numbers can be odd. Therefore, there has to be at least one odd and at least one even number. Then, if there are 5 or more odd numbers, by choosing 5 odd numbers we reach a contradiction. If there are less than 5 odd numbers, by choosing 4 even and one odd number, we also reach a contradiction. Hence, this lemma is proven. (2 points) ■

Let us observe any 5 columns of the given table. For every row of the table, let's compute the sum of numbers in cells which we get by intersecting the row with these 5 columns. That way we get 10 natural numbers (one for each row). The sum of any 5 of these numbers is even (this follows from the conditions of the problem). Now, using **Lemma 1**, we conclude that each of these 10 sums is even. (4 points)

By observing all possible choices of 5 columns of the given table, we get that the sum of each 5 numbers of every row is even. Again, using **Lemma 1**, we conclude that every number in each row is even. Therefore, all numbers in the table is even. (4 points) ■

**Problem 3.** Let  $M_n$  and  $N_n$  be points on sides  $\overline{CA}$  and  $\overline{CB}$  of triangle  $ABC$ , respectively, such that

$$|CM_n| = \frac{1}{n} |CA|, \quad |CN_n| = \frac{1}{n+1} |CB|, \quad \forall n \in \mathbb{N}.$$

Find the locus of points  $M_iN_i \cap M_jN_j$ , where  $i$  and  $j$  are different natural number.

**Note.**  $M_iN_i \cap M_jN_j$  denotes the intersection of lines  $M_iN_i$  and  $M_jN_j$ .

**Solution.** We intend to show that all the mentioned lines intersect in one point. That will be point  $D$  such that quadrilateral  $ABDC$  is a parallelogram. (1 point)

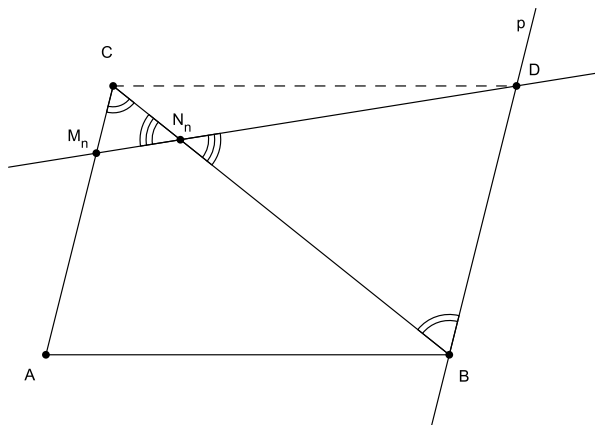

Let  $n$  be any natural number. We draw line  $p$  parallel to line  $AC$  such that  $B$  is on  $p$ . Let  $D$  be the intersection of  $p$  i  $M_nN_n$ . Let us notice that  $\angle M_nCN_n = \angle ACB = \angle CBD = \angle N_nBD$  (alternate interior angles) and  $\angle CN_nM_n = \angle BN_nD$  (vertical angles). So, we have shown that triangles  $CM_nN_n$  and  $BDN_n$  are similar (they have two equal angles). (2 points)

Now,

$$\frac{|BD|}{|CM_n|} = \frac{|BN_n|}{|CN_n|},$$

which means

$$\begin{aligned} |BD| &= \frac{|CM_n| \cdot |BN_n|}{|CN_n|} = \frac{\frac{1}{n} \cdot |CA| \cdot (|CB| - |CN_n|)}{|CN_n|} \\ &= \frac{\frac{1}{n} |CA| \cdot (|CB| - \frac{1}{n+1} |CB|)}{\frac{1}{n+1} |CB|} \\ &= \frac{\frac{1}{n} |CA| \cdot \frac{n}{n+1} |CB|}{\frac{1}{n+1} |CB|} \\ &= |CA|. \end{aligned}$$

With this, we have shown that  $|BD| = |AC|$  and, since we know that  $BD \parallel AC$ , it follows that quadrilateral  $ABDC$  is a parallelogram. (4 points)

Now we know that line  $M_n N_n$  goes through point  $D$  such that quadrilateral  $ABDC$  is a parallelogram for each natural number  $n$ . Finally, we conclude that the locus of  $M_i N_i \cap M_j N_j$ , where  $i$  and  $j$  are different natural numbers, is point  $D$  such that quadrilateral  $ABDC$  is a parallelogram. (3 points) ■

**Problem 4.**  $a$ ,  $b$  and  $c$  are natural numbers. It is known that  $a^2 + b^2 + abc$  has no more than 2008 natural divisors and that it is divisible by  $(c + 2)^{1004}$ . Prove that  $a$  and  $b$  are not relatively prime. (Adrian Satja Kurdija)

**Solution.** Let  $A = a^2 + b^2 + abc$  and  $p = c + 2$ , having in mind that then  $p \geq 3$ . Let's assume that there exists a prime number  $q$  such that  $q^2 \mid p$ . Then,  $q^{2008} \mid A$ , and as  $q^{2008}$  itself has  $2009 > 2008$  divisors, we reach a contradiction. So, there does not exist a prime number  $q$  such that  $q^2 \mid p$ . Further, let us assume that there exist different prime numbers  $r$  and  $s$  which divide  $p$ . Then,  $r^{1004} s^{1004} \mid A$  and, obviously,  $1005^2 > 2008$  and we, again, have a contradiction. Hence, there do not exist two different prime numbers which both divide  $p$ . With all of this, we have shown that  $p$  is prime. (2 points)

Now,  $c = p - 2$ , and, for that reason,

$$A = a^2 + b^2 + abc = a^2 + b^2 + ab(p - 2) = a^2 - 2ab + b^2 + abp = (a - b)^2 + abp.$$

Since  $p \mid A$  and  $p \mid abp$ , it follows that  $p \mid (a - b)^2$  and, since  $p$  is prime, it further follows that  $p \mid a - b$ . From this, we conclude finally that  $p^2 \mid (a - b)^2$ . (2 points)

Furthermore,  $p^2 \mid A$  and  $p^2 \mid (a - b)^2$ , so  $p^2 \mid abp$ , which leads to  $p \mid ab$ , must also be true. (1 point)

Now we know that  $p \mid a - b$ ,  $p \mid ab$  and that  $p$  is prime. Since  $p \mid ab$ , this means that  $p$  divides at least one of the numbers  $a$  and  $b$ . (1 point)

Without loss of generality, we may assume that  $p \mid a$ . Then, from  $p \mid a - b$ , it directly follows that  $p \mid b$ . So, numbers  $a$  and  $b$  are not relatively prime. (4 points) ■

# 1<sup>st</sup> BALKAN STUDENT MATHEMATICAL COMPETITION

1. Matematičko natjecanje učenika Balkana

November 2008.

3<sup>rd</sup> and 4<sup>th</sup> grade

**Problem 1.** Find all functions  $f: \mathbb{R} \rightarrow \mathbb{R}$  such that for every two real numbers  $x$  and  $y$ ,

$$f(f(x) + xy) = f(x) \cdot f(y + 1).$$

(Marko Radovanović)

**Problem 2.** Paralampius the Gnu stands on number 1 on number line. He wants to come to a natural number  $k$  by a sequence of consecutive jumps. Let us denote the number of ways on which Paralampius can come from number 1 to number  $k$  with  $f(k)$  ( $f: \mathbb{N} \rightarrow \mathbb{N}_0$ ). Specially,  $f(1) = 0$ . A way is a sequence of numbers (with order) which Paralampius has visited on his travel from number 1 to number  $k$ . Paralampius can, from number  $b$ , jump to number

- $2b$  (always),
- $3b$  (always),
- $b^2$  (if  $\frac{b^4}{6k} \in \mathbb{N}$ , where  $k$  is a natural number on which he wants to come to in the end).

Prove that, for every natural number  $n$ , there exists a natural number  $m_0$  such that for every natural number  $m > m_0$ ,

$$f(m) < 2^{\alpha_1 + \alpha_2 + \dots + \alpha_i - n},$$

where  $m = p_1^{\alpha_1} \cdot p_2^{\alpha_2} \cdot \dots \cdot p_i^{\alpha_i}$  ( $p_1 < p_2 < \dots < p_i$  are prime divisors of number  $m$  and  $i, \alpha_1, \alpha_2, \dots, \alpha_i$  are natural numbers) is a prime factorization of natural number  $m$ . It is known that this factorization is unique for every natural number  $m > 1$ .

(Melkior Ornik, Ivan Krijan)

**Problem 3.** A convex  $n$ -gon ( $n \in \mathbb{N}, n > 2$ ) is given in the plane. Its area is less than 1. For each point  $X$  of this plane, we shall denote with  $F(X)$  the area of the convex hull of point  $X$  and a given  $n$ -gon (the area of the minimal convex polygon which includes both the point  $X$  and a given  $n$ -gon). Prove that the set of points for which  $F(X) = 1$  is a convex polygon with  $2n$  sides or less.

**Problem 4.** Prove that for every natural number  $k$ , there exists infinitely many natural numbers  $n$  such that

$$\frac{n - d(n^r)}{r} \in \mathbb{Z}, \text{ for every } r \in \{1, 2, \dots, k\}.$$

Here,  $d(x)$  denotes the number of natural divisors of a natural number  $x$ , including 1 and  $x$  itself.

(Melkior Ornik)

Time allowed: 240 minutes.

Each problem is worth 10 points.

Write each problem on a separate paper.

Calculators or any other helping items, excluding rulers and compasses, are not allowed.

# 1<sup>st</sup> BALKAN STUDENT MATHEMATICAL COMPETITION

1. Matematičko natjecanje učenika Balkana

November 2008.

3<sup>rd</sup> and 4<sup>th</sup> grade

Solutions

**Problem 1.** Find all functions  $f: \mathbb{R} \rightarrow \mathbb{R}$  such that for every two real numbers  $x$  and  $y$ ,

$$f(f(x) + xy) = f(x) \cdot f(y + 1).$$

(Marko Radovanović)

**Solution.** Obvious solutions are  $f(x) \equiv 0, \forall x \in \mathbb{R}; f(x) \equiv 1, \forall x \in \mathbb{R}$  and  $f(x) \equiv x, \forall x \in \mathbb{R}$ .

(1 point)

Let  $x := 0, y := t - 1$ . Then,  $f(f(0)) = f(0)f(t), \forall t \in \mathbb{R}$ .

(1 point)

Let us consider two cases.

1°  $f(0) \neq 0$ . Then, for each  $t \in \mathbb{R}$ , it is true that  $f(t) = \frac{f(f(0))}{f(0)} = k$ . (1 point)

By plugging  $t = 0$ , we reach  $f(0)^2 = f(f(0))$  or  $k^2 = k$ . If  $k = 0$ , we get  $f(0) = 0$ , which gives a contradiction. So,  $k = 1$  must hold. In that case, we reach this solution:  $f(x) \equiv 1, \forall x \in \mathbb{R}$ .

(2 points)

2°  $f(0) = 0$ . Now we shall consider following two cases:

- $f(x) = 0$  if and only if  $x = 0$ . Then, if we plug  $y := -1$ , we reach

$$f(f(x) - x) = f(x)f(0) = 0 \implies f(x) - x = 0 \implies f(x) = x.$$

So, in this case we reach this solution:  $f(x) \equiv x, \forall x \in \mathbb{R}$ . (2 points)

- There exists a real number  $x_0 \neq 0$  such that  $f(x_0) = 0$ . Then, let  $x := x_0$  and  $y := \frac{t}{x_0}$  for some real number  $t$ . Then,

$$f\left(f(x_0) + x_0 \cdot \frac{t}{x_0}\right) = f(x_0)f\left(\frac{t}{x_0} + 1\right) = 0 \implies f(t) = 0.$$

Finally, we reach the solution  $f(x) \equiv 0, \forall x \in \mathbb{R}$ . (2 points)

We can see that functions mentioned in the beginning (and only those functions) satisfy the conditions of the problem. (1 point) ■

**Problem 2.** Paralampius the Gnu stands on number 1 on number line. He wants to come to a natural number  $k$  by a sequence of consecutive jumps. Let us denote the number of ways on which Paralampius can come from number 1 to number  $k$  with  $f(k)$  ( $f: \mathbb{N} \rightarrow \mathbb{N}_0$ ). Specially,  $f(1) = 0$ . A way is a sequence of numbers (with order) which Paralampius has visited on his travel from number 1 to number  $k$ . Paralampius can, from number  $b$ , jump to number

- $2b$  (always),
- $3b$  (always),
- $b^2$  (if  $\frac{b^4}{6k} \in \mathbb{N}$ , where  $k$  is a natural number on which he wants to come to in the end).

Prove that, for every natural number  $n$ , there exists a natural number  $m_0$  such that for every natural number  $m > m_0$ ,

$$f(m) < 2^{\alpha_1 + \alpha_2 + \dots + \alpha_i - n},$$

where  $m = p_1^{\alpha_1} \cdot p_2^{\alpha_2} \cdot \dots \cdot p_i^{\alpha_i}$  ( $p_1 < p_2 < \dots < p_i$  are prime divisors of number  $m$  and  $i, \alpha_1, \alpha_2, \dots, \alpha_i$  are natural numbers) is a prime factorization of natural number  $m$ . It is known that this factorization is unique for every natural number  $m > 1$ .

(Melkior Ornik, Ivan Krijan)

**Solution.** Let's notice that Paralampius can only reach numbers of the form  $2^a \cdot 3^b$  ( $a, b \in \mathbb{N}_0$ ). That is because neither one of the allowed jumps "introduces" a prime factor different than 2 or 3 (first jump "introduces" 2, second one "introduces" 3, while the last one doubles the number of each of already existing prime numbers). Therefore, for each natural number  $m$  divisible by a prime number  $p > 3$ , it holds that  $f(m) = 0 < 2^{\alpha_1 + \alpha_2 + \dots + \alpha_i - n}$ ,  $\forall n \in \mathbb{N}$ . Specially, the same claim holds for  $f(1)$ . Let us continue by observing only numbers of the form  $2^a \cdot 3^b$  ( $a, b \in \mathbb{N}_0$ ), where at least one of numbers  $a$  and  $b$  differs from 0. Let's introduce the following symbols.

1.  $(k, l)$ ,  $k, l \in \mathbb{N}_0$ ,  $k^2 + l^2 \geq 1$  will denote number  $2^k \cdot 3^l$ . This  $k$  can be any nonnegative integer – it has no connection to  $k$  from the text of the problem.
2.  $g: \mathbb{N}_0 \times \mathbb{N}_0 \rightarrow \mathbb{N}_0$ ,  $g(k, l) = f(2^k \cdot 3^l)$ ,  $k^2 + l^2 \geq 1$ .

Now we can write that Paralampius can jump from pair  $(k, l)$  to pair

- $(k + 1, l)$  (always),
- $(k, l + 1)$  (always),
- $(2k, 2l)$  (if  $4k \geq a + 1$  and  $4l \geq b + 1$  with pair  $(a, b)$  being the goal).

Let pair  $(a, b)$  in further text always mark the number which is Paralampius' goal. Let's show that Paralampius can jump according to the third rule once, at most. Let's assume the opposite, that is, that Paralampius has jump from pair  $(k, l)$  to pair  $(2k, 2l)$  and after a couple of jumps, again from pair  $(k_1, l_1)$  to pair  $(2k_1, 2l_1)$ . It is obvious that none of these rules decrease any element in a pair. On the contrary, every rule increases at least one number in a pair, while the third rule increases (doubles) both numbers. So, it is true that  $k_1 \geq 2k \geq \frac{a+1}{2}$ , so  $2k_1 \geq a + 1 > a$ , and, as it has been mentioned previously, none of the rules will decrease numbers in a pair, so Paralampius will never be able to reach pair  $(a, b)$ . Contradiction! So, Paralampius will jump according to the third rule at most once. If he never jumps according to the third rule, he can jump from  $(0, 0)$  to  $(a, b)$  in

$$\binom{a+b}{b}$$

ways. Further, if Paralampius jumps once according to the third rule, for instance from pair  $(k, l)$  to pair  $(2k, 2l)$ , then it must hold for  $k$  and  $l$  that  $4k \geq a + 1$  and  $4l \geq b + 1$  (condition of the problem), but also (to keep Paralampius from "overjumping" the goal, because, as we have shown, he can not return)  $2k \leq a$  and  $2l \leq b$ . So, Paralampius can come from  $(0, 0)$  to  $(a, b)$ , if he jumps once from  $(k, l)$  to  $(2k, 2l)$  in

$$\binom{k+l}{l} \cdot \binom{a+b-2k-2l}{b-2l}$$

ways. According to that, Paralampius can come from  $(0, 0)$  to  $(a, b)$  in, altogether,

$$g(a, b) = \binom{a+b}{b} + \sum_{\frac{a+1}{4} \leq k \leq \frac{a}{2}} \sum_{\frac{b+1}{4} \leq l \leq \frac{b}{2}} \binom{k+l}{l} \cdot \binom{a+b-2k-2l}{b-2l}$$

ways.

(2 points)

Now our problem boils down to showing that for each natural number  $n$  there exists a natural number  $m_0$  such that for every natural number  $2^a \cdot 3^b > m_0$  ( $a, b \in \mathbb{N}_0, a^2 + b^2 \geq 1$ ), it holds that

$$g(a, b) < 2^{a+b-n}.$$

Let us now show three lemmas.

**Lemma 1.** For all natural numbers  $x$  and  $y$ ,  $\binom{x}{y} \leq 2^{x-1}$  holds.

**Proof.** We know that  $\binom{x}{y} \leq \binom{x}{\lfloor \frac{x}{2} \rfloor}$ , so it suffices to prove that, for every natural number  $x$ ,  $\binom{x}{\lfloor \frac{x}{2} \rfloor} \leq 2^{x-1}$ . We will show this using mathematical induction. For  $x = 1$ ,  $\binom{1}{0} \leq 2^{1-1}$ . Let's assume that for some  $x \in \mathbb{N}$ ,  $\binom{x}{\lfloor \frac{x}{2} \rfloor} \leq 2^{x-1}$ . Then,

$$\binom{x+1}{\lfloor \frac{x+1}{2} \rfloor} = \binom{x}{\lfloor \frac{x+1}{2} \rfloor} + \binom{x}{\lfloor \frac{x-1}{2} \rfloor} \leq 2^{x-1} + 2^{x-1} = 2^x.$$

We shall notice that equality is only possible if  $x = 1$  or  $x = 2$ . This proves our first lemma.

(1 point)

■

**Lemma 2.** There exists a natural number  $c_1$  such that, if  $a > c_1$  or  $b > c_1$  (then  $a + b > c_1$ ), then

$$(a+3)(b+3) < 2^{\frac{a+b}{4}}.$$

**Proof.** If we fix  $a + b$ , then the left side reaches its maximum for  $a = b$ . Let then be  $M = a + b + 6$ . Then,

$$M = (a+3) + (b+3) \geq [\text{using AM-GM inequality}] \geq 2\sqrt{(a+b)(b+3)}.$$

So, it suffices to show that there exists a natural number  $c_1$  such that for every natural number  $x > c_1$  it holds that

$$(x+3)^2 < 2^{\frac{x}{2}} \iff (x+3)^4 < 2^x.$$

It is obvious that the left side of this inequality “grows more slowly” than the right side, so it is enough to show that there exists at least one such natural number  $x$ . We can directly see that, for example,  $x = 20$  has this property.

(1 point)

■

**Lemma 3.** For every natural number  $n$  there exists natural number  $c$  such that, if  $a > c$  or  $b > c$  (then  $a + b > c$ ), then

$$\binom{a+b}{b} < 2^{a+b-n-1}.$$

**Proof.** We know that

$$\binom{a+b}{b} \leq \binom{a+b}{\lfloor \frac{a+b}{2} \rfloor},$$

so, in general,

$$\binom{a+b}{b} \leq \binom{2x}{x}, \quad \text{where } x = \left\lceil \frac{a+b}{2} \right\rceil.$$

Now, it is enough to show that for each natural number  $n$  there exists natural number  $c$  such that, if  $x > c$ , then

$$\binom{2x}{x} < 2^{2x-n-1}.$$

Further, let us notice that  $\binom{2x+2}{x+1} < 4 \cdot \binom{2x}{x} \iff 2 > 0$ , and  $2^{2x+2-n-1} = 4 \cdot 2^{2x-n-1}$ . So, it inductively follows that, if we show that there exists  $c \in \mathbb{N}$  such that  $\binom{2c}{c} < 2^{2c-n-1}$ , then, for every natural number  $x > c$ ,  $\binom{2x}{x} < 2^{2x-n-1}$  will hold. Let us now prove that such  $c \in \mathbb{N}$  exists.

$$\begin{aligned} & \binom{2c}{c} < 2^{2c-n-1} \\ \iff & \frac{(2c)!}{c! \cdot c!} < 2^{2c-n-1} \\ \iff & \frac{(2c)(2c-1)(2c-2) \cdots 2 \cdot 1}{c^2 (c-1)^2 (c-2)^2 \cdots 2^2 \cdot 1^2} < 2^{2c-n-1} \\ \iff & \frac{2^c \cdot c(c-1)(c-2) \cdots 2 \cdot 1 \cdot (2c-1)(2c-3) \cdots 3 \cdot 1}{c^2 (c-1)^2 \cdots 2^2 \cdot 1^2} < 2^{2c-n-1} \\ \iff & \frac{(2c-1)(2c-3) \cdots 3 \cdot 1}{c(c-1) \cdots 2 \cdot 1} < 2^{c-n-1} \\ \iff & \frac{(2c-1)(2c-3) \cdots 3 \cdot 1}{2^c \cdot c(c-1) \cdots 2 \cdot 1} < 2^{-n-1} \\ \iff & \frac{(2c)(2c-2)(2c-4) \cdots 4 \cdot 2}{(2c-1)(2c-3) \cdots 3 \cdot 1} > 2^{n+1} \\ \iff & \left(1 + \frac{1}{2c-1}\right) \left(1 + \frac{1}{2c-3}\right) \cdots \left(1 + \frac{1}{1}\right) > 2^{n+1}. \end{aligned}$$

Obviously  $\left(1 + \frac{1}{2c-1}\right) \left(1 + \frac{1}{2c-3}\right) \cdots \left(1 + \frac{1}{1}\right) \geq \frac{1}{2c-1} + \frac{1}{2c-3} + \cdots + \frac{1}{1}$  for every natural number  $c$ , so it suffices to show that there exists a natural number  $c$  such that

$$\frac{1}{2c-1} + \frac{1}{2c-3} + \cdots + \frac{1}{1} > 2^{n+1}.$$

Since  $\frac{1}{2c-1} + \frac{1}{2c-3} + \cdots + \frac{1}{1} \geq \frac{1}{2c} + \frac{1}{2c-2} + \cdots + \frac{1}{2}$ , that is,

$$\frac{1}{2c-1} + \frac{1}{2c-3} + \cdots + \frac{1}{1} \geq \frac{\frac{1}{c} + \frac{1}{c-1} + \cdots + \frac{1}{1}}{2},$$

it is enough for us to show that there exists a natural number  $c$  such that

$$\frac{1}{c} + \frac{1}{c-1} + \cdots + \frac{1}{1} > 2^{n+2}.$$

Let's notice that for every nonnegative integer  $t$ ,  $\frac{1}{2^t+1} + \frac{1}{2^t+2} + \cdots + \frac{1}{2^{t+1}} \geq \frac{1}{2}$ . This follows from the fact that, on the left side of the inequality, we have  $2^t$  summands, each one of which is larger or equal than  $\frac{1}{2^{t+1}}$ . Now it directly follows that

$$\frac{1}{2^{2n+3}} + \frac{1}{2^{2n+3}-1} + \frac{1}{2^{2n+3}-2} + \cdots + \frac{1}{1} > 2^{n+2}.$$

With this, we have finally proven this lemma. (3 points)

■

Now, we wish to show that for every natural number  $n$  there exists a natural number  $t$  such that, if  $a > t$  or  $b > t$ , then

$$\sum_{\frac{a+1}{4} \leq k \leq \frac{a}{2}} \sum_{\frac{b+1}{4} \leq l \leq \frac{b}{2}} \binom{k+l}{l} \cdot \binom{a+b-2k-2l}{b-2l} < 2^{a+b-n-1}.$$

Further, let's fix  $n$ . Let  $t$  be such natural number that  $t > c_1$  and  $t > c$ , where  $c_1$  and  $c$  are numbers of **Lemma 2**, that is, from **Lemma 3**. Let us observe numbers defined by pair  $(a, b)$ , where  $a + 1 > 4t$  or  $b + 1 > 4t$ . Then, if Paralampius jumps on his travel from pair  $(k, l)$  to pair  $(2k, 2l)$ , for numbers  $k$  and  $l$  it holds that  $k + l > t$  because  $k \geq \frac{a+1}{4}$  and  $l \geq \frac{b+1}{4}$ , so  $k > t$  or  $l > t$ . So, because of

**Lemma 3**,  $\binom{k+l}{l} < 2^{k+l-n-1}$ . According to **Lemma 1**, we have that for all  $x, y \in \mathbb{N}$ , it holds that  $\binom{x}{y} \leq 2^{x-1}$ , so, because of that,

$$\sum_{\frac{a+1}{4} \leq k \leq \frac{a}{2}} \sum_{\frac{b+1}{4} \leq l \leq \frac{b}{2}} \binom{k+l}{l} \cdot \binom{a+b-2k-2l}{b-2l} < \sum_{\frac{a+1}{4} \leq k \leq \frac{a}{2}} \sum_{\frac{b+1}{4} \leq l \leq \frac{b}{2}} 2^{k+l-n-1} \cdot 2^{a+b-2k-2l-1}.$$

Since  $k > \frac{a}{4}$  and  $l > \frac{b}{4}$ , we can see that it suffices to show that (we set  $k$  to be exactly equal to  $\frac{a}{4}$  and the same for  $l$ )

$$\sum_{\frac{a+1}{4} \leq k \leq \frac{a}{2}} \sum_{\frac{b+1}{4} \leq l \leq \frac{b}{2}} 2^{\frac{3}{4}a + \frac{3}{4}b - n - 2} < 2^{a+b-n-1}.$$

It is obvious that there exists at most  $\frac{a}{2} - \frac{a+1}{4} + 1 = \frac{a+3}{4}$  possible numbers  $k$ . The same is true for numbers  $l$ . So, it is enough for us to show

$$(a+3)(b+3) \cdot 2^{\frac{3}{4}a + \frac{3}{4}b - n - 5} < 2^{a+b-n}.$$

Since  $a > 4t - 1$  or  $b > 4t - 1$ , then  $a > t$  or  $b > t$  and, since  $t > c_1$ , where  $c_1$  is the number from **Lemma 2**, it is obvious that  $a > c_1$  or  $b > c_1$ , so, because of **Lemma 2**, wanted inequality directly follows. With this we have shown that for every natural number  $n$ , there exists a natural number  $t$  such that, if  $a > t$  or  $b > t$ , then

$$\sum_{\frac{a+1}{4} \leq k \leq \frac{a}{2}} \sum_{\frac{b+1}{4} \leq l \leq \frac{b}{2}} \binom{k+l}{l} \cdot \binom{a+b-2k-2l}{b-2l} < 2^{a+b-n-1}.$$

In our case, this natural number  $t$  is such that  $t > 4c_1$  and  $t > 4c$ , where  $c_1$  and  $c$  are numbers from **Lemma 2**, that is, from **Lemma 3**. (2 points)

It is obvious that, for such natural number  $t$ , because of **Lemma 3**, the following holds:

$$\binom{a+b}{b} < 2^{a+b-n-1}.$$

By adding the last two inequalities (we have shown that they hold), we reach that

$$g(a, b) < 2^{a+b-n},$$

what we have wanted to show. That is, we have shown that for every natural number  $n$  there exists a natural number  $m_0$  such that for every natural number  $2^a \cdot 3^b > m_0$  ( $a, b \in \mathbb{N}_0$ ,  $a^2 + b^2 \geq 1$ ), it holds that

$$g(a, b) < 2^{a+b-n}.$$



**Problem 3.** A convex  $n$ -gon ( $n \in \mathbb{N}$ ,  $n > 2$ ) is given in the plane. Its area is less than 1. For each point  $X$  of this plane, we shall denote with  $F(X)$  the area of the convex hull of point  $X$  and a given  $n$ -gon (the area of the minimal convex polygon which includes both the point  $X$  and a given  $n$ -gon). Prove that the set of points for which  $F(X) = 1$  is a convex polygon with  $2n$  sides or less.

**Solution.** Let  $S$  be the set of all points  $T$  of the given plane such that  $F(T) = 1$ . It is obvious that all these points  $T$  are outside the given  $n$ -gon. Area of the given  $n$ -gon is less than 1, and when point  $T$  belongs to the interior (or the edge) of the given  $n$ -gon, it itself becomes our wanted convex hull. (1 point)

Point  $T$  is outside the  $n$ -gon if there exists a line which passes through  $T$  such that it has no common points with the  $n$ -gon. Let's observe the following image.

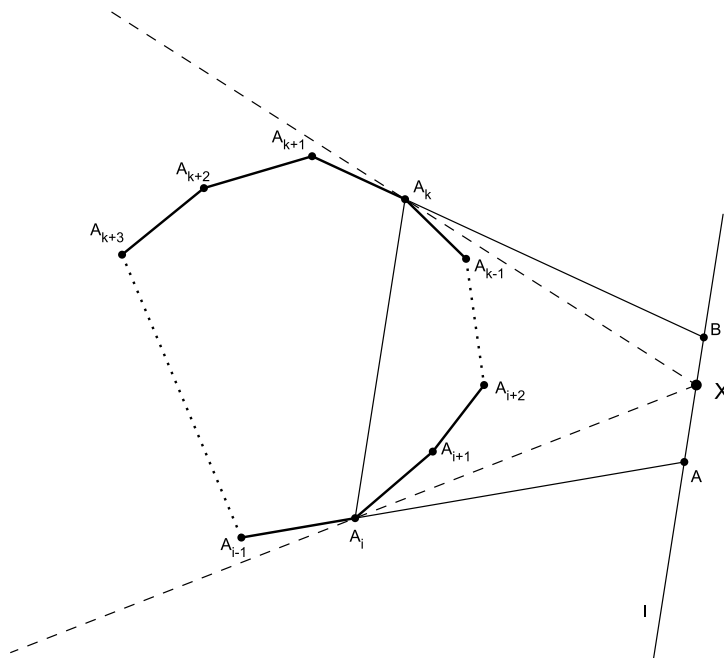

Let  $A_0, A_1, \dots, A_{n-1}$  be vertices of the given  $n$ -gon. Also, let  $A_j = A_{(j \bmod n)}$  ( $j \in \mathbb{Z}$ ), where  $(j \bmod n) = x$  is a number from the set  $\{0, 1, \dots, n-1\}$  such that  $j \equiv x \pmod{n}$ . We say that a diagonal of the given  $n$ -gon is *visible* if the entire  $n$ -gon is inside the angle with its vertex in  $T$  whose chord is that diagonal. For example, (observe image) diagonal  $\overline{A_iA_k}$  ( $i, k \in \mathbb{Z}$ ), with respect to  $X$ , is visible. (1 point)

$\overline{A_iA_k}$  is a visible diagonal. Inside the triangle  $A_iXA_k$  there are vertices  $A_{i+1}, A_{i+2}, \dots, A_{k-1}$  and outside of it all the remaining vertices of the given  $n$ -gon. So, the area  $F(X)$  is equal to the sum of areas of the triangle  $A_iXA_k$  and polygon  $A_kA_{k+1} \dots A_{i-1}A_i$ . (1 point)

Let  $l$  be a line through  $X$  parallel to the line  $A_iA_k$  and let  $A$  and  $B$  be the intersections of  $l$  and lines  $A_{i-1}A_i$  and  $A_{k+1}A_k$ , respectively. (1 point)

If  $F(X) = 1$ , then  $X$  is an element of  $S$ . Then, it is obvious that all points  $T$  that are on line  $l$  and for which  $\overline{A_iA_k}$  is a visible diagonal are also elements of set  $S$ . Furthermore, diagonal  $\overline{A_iA_k}$  is no longer visible to the point  $T$  as  $T$  moves on  $l$  and becomes colinear with some side of the given  $n$ -gon. So, all points  $T$  of line  $l$  that are possibly in  $S$  (which they are if  $X$  is in  $S$ ) are on the segment  $\overline{AB}$ . (2 points)

Now we can easily deduce the following conclusion: By observing all points  $T \in S$  we can see that, as they "go around" the given  $n$ -gon, with them also rotate their respective visible diagonals. Every point of the given  $n$ -gon can, therefore, become one endpoint of some of the visible diagonals (visible diagonals interesting to us – those who are visible with respect to some point from the set  $S$ )

exactly once, and only exactly once stop being the endpoint. Because of that, there can be at most  $2n$  interesting visible diagonals. It is clear that we will get a convex polygon – as point  $T$  rotates around the given  $n$ -gon, segments  $\overline{AB}$  rotate with her and one always “connects” itself to the other one.

(5 points) ■

**Problem 4.** Prove that for every natural number  $k$ , there exist infinitely many natural numbers  $n$  such that

$$\frac{n - d(n^r)}{r} \in \mathbb{Z}, \text{ for every } r \in \{1, 2, \dots, k\}.$$

Here,  $d(x)$  denotes the number of natural divisors of a natural number  $x$ , including 1 and  $x$  itself.

(Melkior Ornik)

**Solution.** Let us first prove the following lemma.

**Lemma 1.**  $d(n^r) \equiv 1 \pmod{r}$ .

**Proof.** Let  $n = p_1^{\alpha_1} \cdot p_2^{\alpha_2} \cdot \dots \cdot p_i^{\alpha_i}$ , where  $p_1 < p_2 < \dots < p_i$  are all prime divisors of the natural number  $n$  and  $i, \alpha_1, \alpha_2, \dots, \alpha_i$  are natural numbers, be the prime factorization of  $n$ . Then,

$$n^r = p_1^{r\alpha_1} \cdot p_2^{r\alpha_2} \cdot \dots \cdot p_i^{r\alpha_i},$$

that is,  $d(n^r) = (r\alpha_1 + 1) \cdot (r\alpha_2 + 1) \cdot \dots \cdot (r\alpha_i + 1)$ .

(1 point)

Clearly, for every  $j \in \{1, 2, \dots, i\}$ , the following holds:  $r\alpha_j + 1 \equiv 1 \pmod{r}$ , so

$$d(n^r) \equiv (r\alpha_1 + 1) \cdot (r\alpha_2 + 1) \cdot \dots \cdot (r\alpha_i + 1) \equiv 1^i \equiv 1 \pmod{r}.$$

This has proven the lemma.

(1 point) ■

Now, our problem (because of **Lemma 1**) boils down to showing that for every natural number  $k$  there exists infinitely many natural numbers  $n$  such that

$$r \mid n - 1, \quad \forall r \in \{1, 2, \dots, k\}.$$

Let  $n = m \cdot k! + 1$ ,  $m$  being a natural number.

(1 point)

Now it is obvious that  $n \equiv m \cdot k! + 1 \equiv [ \text{because of } r \mid k! ] \equiv 1 \pmod{r}$  for every  $r \in \{1, 2, \dots, k\}$ .

Because of that, for this choice of number  $n$  we have  $r \mid n - 1$  for every  $r \in \{1, 2, \dots, k\}$ . (1 point)

As  $m$  can be any natural number, for every natural number  $k$  there exists infinitely many natural numbers  $n$  such that  $r \mid n - 1$  for every  $r \in \{1, 2, \dots, k\}$ . This is, because of **Lemma 1**, equivalent to the problem claim.

(6 points) ■



1<sup>ST</sup> EUROPEAN MATHEMATICAL CUP  
24<sup>th</sup> November 2012–1<sup>st</sup> December 2012  
Junior Category



**Problem 1.** Let  $ABC$  be a triangle and  $Q$  a point on the internal angle bisector of  $\angle BAC$ . Circle  $\omega_1$  is circumscribed to triangle  $BAQ$  and intersects the segment  $AC$  in point  $P \neq C$ . Circle  $\omega_2$  is circumscribed to the triangle  $CQP$ . Radius of the circle  $\omega_1$  is larger than the radius of  $\omega_2$ . Circle centered at  $Q$  with radius  $QA$  intersects the circle  $\omega_1$  in points  $A$  and  $A_1$ . Circle centered at  $Q$  with radius  $QC$  intersects  $\omega_1$  in points  $C_1$  and  $C_2$ . Prove  $\angle A_1BC_1 = \angle C_2PA$ .

(Matija Bucić)

**Problem 2.** Let  $S$  be the set of positive integers. For any  $a$  and  $b$  in the set we have  $GCD(a, b) > 1$ . For any  $a$ ,  $b$  and  $c$  in the set we have  $GCD(a, b, c) = 1$ . Is it possible that  $S$  has 2012 elements?

$GCD(x, y)$  and  $GCD(x, y, z)$  stand for the greatest common divisor of the numbers  $x$  and  $y$  and numbers  $x$ ,  $y$  and  $z$  respectively.

(Ognjen Stipetić)

**Problem 3.** Do there exist positive real numbers  $x$ ,  $y$  and  $z$  such that

$$\begin{aligned}x^4 + y^4 + z^4 &= 13, \\x^3y^3z + y^3z^3x + z^3x^3y &= 6\sqrt{3}, \\x^3yz + y^3zx + z^3xy &= 5\sqrt{3}?\end{aligned}$$

(Matko Ljulj)

**Problem 4.** Let  $k$  be a positive integer. At the European Chess Cup every pair of players played a game in which somebody won (there were no draws). For any  $k$  players there was a player against whom they all lost, and the number of players was the least possible for such  $k$ . Is it possible that at the Closing Ceremony all the participants were seated at the round table in such a way that every participant was seated next to both a person he won against and a person he lost against.

(Matija Bucić)

*Time allowed: 240 minutes.*

*Each problem is worth 10 points.*

*Calculators are not allowed.*



## Problems and solutions

**Problem 1.** Let  $ABC$  be a triangle and  $Q$  a point on the internal angle bisector of  $\angle BAC$ . Circle  $\omega_1$  is circumscribed to triangle  $BAQ$  and intersects the segment  $AC$  in point  $P \neq C$ . Circle  $\omega_2$  is circumscribed to the triangle  $CQP$ . Radius of the circle  $\omega_1$  is larger than the radius of  $\omega_2$ . Circle centered at  $Q$  with radius  $QA$  intersects the circle  $\omega_1$  in points  $A$  and  $A_1$ . Circle centered at  $Q$  with radius  $QC$  intersects  $\omega_1$  in points  $C_1$  and  $C_2$ . Prove  $\angle A_1BC_1 = \angle C_2PA$ .

(Matija Bucić)

**Solution.** From the conditions in the problem we have  $|QC_1| = |QC_2|$  and  $|QA| = |QA_1|$ . Also as  $Q$  lies on the internal angle bisector of  $\angle CAB$  we have  $\angle PAQ = \angle QAB \implies |QP| = |QB|$ .

Now noting from this that pairs of points  $A$  and  $A_1$ ,  $C_1$  and  $C_2$ ,  $B$  and  $P$  are symmetric in line  $QS_1$ , where  $S_1$  is the center of  $\omega_1$ . We can directly conclude  $\angle A_1BC_1 = \angle APC_2$  as these is the image of the angle in symmetry.

This way we have avoided checking many cases but there are many ways to prove this problem.

**Problem 2.** Let  $S$  be the set of positive integers. For any  $a$  and  $b$  in the set we have  $GCD(a, b) > 1$ . For any  $a, b$  and  $c$  in the set we have  $GCD(a, b, c) = 1$ . Is it possible that  $S$  has 2012 elements?

$GCD(x, y)$  and  $GCD(x, y, z)$  stand for the greatest common divisor of the numbers  $x$  and  $y$  and numbers  $x, y$  and  $z$  respectively.

(Ognjen Stipetić)

**Solution.** There is such a set.

We will construct it in the following way: Let  $a_1, a_2, \dots, a_{2012}$  equal to 1 in the beginning. Then we take  $\frac{2012 \cdot 2011}{2}$  different prime numbers, and assign a different prime to every pair  $a_i, a_j$  (where  $i \neq j$ ) and multiply them with this assigned number. (I.e. for the set of 4 elements we can take 2, 3, 5, 7, 11, 13, so  $S$  would be  $\{2 \cdot 3 \cdot 5, 2 \cdot 7 \cdot 11, 3 \cdot 7 \cdot 13, 5 \cdot 11 \cdot 13\}$ .)

The construction works as we have multiplied any pair of numbers with some prime so the condition  $gcd(a, b) > 1$  is satisfied for all  $a, b$ . As well as each prime divides exactly 2 primes so no three numbers  $a, b, c$  can have  $gcd(a, b, c) > 1$ .

**Problem 3.** Do there exist positive real numbers  $x, y$  and  $z$  such that

$$\begin{aligned} x^4 + y^4 + z^4 &= 13, \\ x^3y^3z + y^3z^3x + z^3x^3y &= 6\sqrt{3}, \\ x^3yz + y^3zx + z^3xy &= 5\sqrt{3} \end{aligned}$$

(Matko Ljulj)

**Solution.** Let's assume that such  $x, y, z$  exist. Let  $a = x^2, b = y^2, c = z^2$ . As well, let  $A = a + b + c, B = ab + bc + ca, C = abc$ . The upper system can be rewritten as:

$$\begin{aligned} a^2 + b^2 + c^2 = 13 &\implies (a + b + c)^2 - 2(ab + bc + ca) = 13 \implies A^2 - 2B = 13 \\ xyz(x^2y^2 + y^2z^2 + z^2x^2) = 6\sqrt{3} &\implies \sqrt{CB} = 6\sqrt{3} \\ xyz(x^2 + y^2 + z^2) = 5\sqrt{3} &\implies \sqrt{CA} = 5\sqrt{3}. \end{aligned}$$

We can note that  $a$ ,  $b$  and  $c$  are positive reals (They are not negative from the definition; and as  $\sqrt{C}B = 6\sqrt{3}$  they are not 0).

When we cancel out  $\sqrt{C}$  from the second and third equation we get  $5B = 6A$ . When we express  $B$  in terms of  $A$  and put into the first equation we get a quadratic equation

$$A^2 - \frac{12}{5}A - 13 = 0.$$

with solutions  $5$  and  $-\frac{13}{5}$ . As  $a$ ,  $b$  and  $c$  are positive reals, and the sum must be positive so their sum is positive real number as well. So  $A = 5 \implies B = 6 \implies C = 3$ .

By *AM-GM* inequality we get

$$\begin{aligned} \frac{ab + bc + ca}{3} &\geq \sqrt[3]{ab \cdot bc \cdot ca} \\ \iff \frac{B}{3} &\geq \sqrt[3]{C^2} \\ \iff \frac{6}{3} &\geq \sqrt[3]{9} /^3 \\ \iff 8 &\geq 9. \end{aligned}$$

so we reached a contradiction, thus such  $x, y, z$  don't exist.

**Problem 4.** Let  $k$  be a positive integer. At the European Chess Cup every pair of players played a game in which somebody won (there were no draws). For any  $k$  players there was a player against whom they all lost, and the number of players was the least possible for such  $k$ . Is it possible that at the Closing Ceremony all the participants were seated at the round table in such a way that every participant was seated next to both a person he won against and a person he lost against.

*(Matija Bucić)*

**Solution.** The answer is yes.

In this problem we could use graph theory terminology but as this problem was intended for younger students we shall avoid mentioning any specific graph theory terms.

Let's take the largest number of participants whom we can seat around the table as desired. If we have seated all the participants we are done. Otherwise there is a person not seated at the table. As well there is at least one person seated at the table so let's name it  $a$ .

WLOG we can assume that for each person seated at the table to his right there is a person he won against and to his left a person he lost against.

Denote by  $W$  the set of people who won against person  $a$ , and are not seated at the table. Similarly, let  $L$  denote the set of all people who lost against  $a$  and are not seated at the table.

Let's consider any person  $p$  from  $W$ . If person  $p$  lost against the left neighbour of  $a$ , then we could seat  $p$  in between  $a$  and his (former) left neighbour, which is a contradiction with the assumption that we have seated the maximal possible number of people. So  $p$  won against the left neighbour of  $a$ . Using similar deduction we conclude that  $p$  won against the next left neighbour as well etc. So  $p$  must have won against everybody seated at the table.

In the same way if we consider any person  $q$  from  $L$  and consider the right neighbour of  $a$ , we can conclude that  $q$  lost against every person seated at the table.

If some person  $r$  from  $W$  lost against some person  $s$  in  $L$ , then instead of seating  $a$  we can seat  $s$  and  $r$  respectively by which we would reach a contradiction to the number of people seated being maximal.

So we conclude that all the people in  $W$  won against all people not in  $W$  and all the people in  $L$  lost against all people not in  $L$ .

As there is a someone who is not seated either  $W$  or  $L$  is non-empty. If  $W$  is non-empty, we can consider the set  $W$  as an independent chess cup. It is a cup with smaller number of participants but still satisfying problem conditions which would be the contradiction with the fact that our starting cup is the smallest such cup.

As well if  $L$  is non-empty, the smaller cup made by people seated at the table and people in  $W$  also satisfies the problem conditions and gives us a contradiction.

So the only possibility is that both  $W$  and  $L$  are empty so indeed it is possible to seat everyone at such table.



1<sup>ST</sup> EUROPEAN MATHEMATICAL CUP  
24<sup>th</sup> November 2012–1<sup>st</sup> December 2012  
Senior Category



**Problem 1.** Find all positive integers  $a, b, n$  and prime numbers  $p$  that satisfy

$$a^{2013} + b^{2013} = p^n.$$

(Matija Bucić)

**Problem 2.** Let  $ABC$  be an acute triangle with orthocenter  $H$ . Segments  $AH$  and  $CH$  intersect segments  $BC$  and  $AB$  in points  $A_1$  and  $C_1$  respectively. The segments  $BH$  and  $A_1C_1$  meet at point  $D$ . Let  $P$  be the midpoint of the segment  $BH$ . Let  $D'$  be the reflection of the point  $D$  in  $AC$ . Prove that quadrilateral  $APCD'$  is cyclic.

(Matko Ljulj)

**Problem 3.** Prove that the following inequality holds for all positive real numbers  $a, b, c, d, e$  and  $f$ :

$$\sqrt[3]{\frac{abc}{a+b+d}} + \sqrt[3]{\frac{def}{c+e+f}} < \sqrt[3]{(a+b+d)(c+e+f)}.$$

(Dimitar Trenevski)

**Problem 4.** Olja writes down  $n$  positive integers  $a_1, a_2, \dots, a_n$  smaller than  $p_n$  where  $p_n$  denotes the  $n$ -th prime number. Oleg can choose two (not necessarily different) numbers  $x$  and  $y$  and replace one of them with their product  $xy$ . If there are two equal numbers Oleg wins. Can Oleg guarantee a win?

(Matko Ljulj)

*Time allowed: 240 minutes.*

*Each problem is worth 10 points.*

*Calculators are not allowed.*



## Problems and solutions

**Problem 1.** Find all positive integers  $a, b, n$  and prime numbers  $p$  that satisfy

$$a^{2013} + b^{2013} = p^n.$$

(Matija Bucić)

**First solution.** Let's denote  $d = D(a, b), x = \frac{a}{d}, y = \frac{b}{d}$ . With this we get

$$d^{2013}(a^{2013} + b^{2013}) = p^n.$$

So  $d$  must be a power of  $p$ , so let  $d = p^k, k \in \mathbb{N}_0$ . We can divide the equality by  $p^{2013k}$ . Now let's denote  $m = n - 2013k, A = x^{671}, B = y^{671}$ . So we get

$$A^3 + B^3 = p^m,$$

and after factorisation

$$(A + B)(A^2 - AB + B^2) = p^m.$$

(From the definition,  $A$  and  $B$  are coprime.)

Let's observe the case when some factor is 1:  $A + B = 1$  is impossible as both  $A$  and  $B$  are positive integers. And  $A^2 - AB + B^2 = 1 \Leftrightarrow (A - B)^2 + AB = 1 \Leftrightarrow A = B = 1$ , so we get a solution  $a = b = 2^k, n = 2013k + 1, p = 2, \forall k \in \mathbb{N}_0$ .

If both factors are larger than 1 we have

$$\begin{aligned} p &| A + B \\ p &| A^2 - AB + B^2 = (A + B)^2 - 3AB \\ &\implies p &| 3AB. \end{aligned}$$

If  $p | AB$ , in accordance with  $p | A + B$  we get  $p | A$  and  $p | B$ , which is in contradiction with  $A$  and  $B$  being coprime. So,  $p | 3 \implies p = 3$ .

Now we are left with 2 cases:

- First case:  $A^2 - AB + B^2 = 3 \Leftrightarrow (A - B)^2 + AB = 3$  – so the only possible solutions are  $A = 2, B = 1$  i  $A = 1, B = 2$ , but this turns out not to be a solution as  $2 = x^{671}$  does not have a solution in positive integers.
- Second case:  $3^2 | A^2 - AB + B^2$  – then we have:

$$\begin{aligned} 3 &| A + B \implies 3^2 | (A + B)^2 \\ 3^2 &| A^2 - AB + B^2 = (A + B)^2 - 3AB \\ &\implies 3^2 | 3AB \\ &\implies 3 | AB. \end{aligned}$$

And as we have already commented the case  $p \nmid AB \implies$  doesn't have any solutions.

So all the solutions are given by

$$a = b = 2^k, n = 2013k + 1, p = 2, \forall k \in \mathbb{N}_0.$$

**Second solution.** As in the first solution, we take the highest common factor of  $a$  and  $b$  (which must be of the form  $p^k$ ). Factorising the given equality we get

$$(x+y)(x^{2012} - x^{2011}y + x^{2010}y^2 - \dots - xy^{2011} + y^{2012}) = p^m.$$

(We're using the same notation as in the first solution.) Denote the right hand side factor by  $A$ . As  $x$  and  $y$  are natural numbers, we have  $x+y > 1 \implies p \mid x+y$ . So  $p \nmid x$  and  $p \nmid y$  (as  $x$  and  $y$  are coprime). Now by applying LTE (Lifting the Exponent Lemma):

$$\nu_p(x^{2013} + y^{2013}) = \nu_p(x+y) + \nu_p(2013)$$

Now we know  $\nu_p(2013) = 0$  for all primes  $p$  except 3, 11, 61, and in the remaining cases  $\nu_p(2013) = 1$ . Note  $A = 1$  and  $(x, y) = (1, 1)$  and  $A > 61$  for  $(x, y) \neq (1, 1)$ . This inequality holds because for  $(x, y) \neq (1, 1)$  (WLOG  $x \geq y$ ), we can write  $A$  as

$$x^{2011}(x-y) + x^{2009}y^2(x-y) + \dots + xy^{2010}(x-y) + y^{2012},$$

which is greater than 61 in cases  $x > y$  and  $y \neq 1$ .

- If  $\nu_p(2013) = 1 \implies \nu_p(A) = 1 \implies A \in \{3, 11, 61\}$  which is clearly impossible.
- If  $\nu_p(2013) = 0 \implies \nu_p(A) = 0 \implies A = 1 \implies (x, y) = (1, 1)$ , so we get a solution

$$a = b = 2^k, n = 2013k + 1, p = 2, \forall k \in \mathbb{N}_0.$$

**Problem 2.** Let  $ABC$  be an acute triangle with orthocenter  $H$ . Segments  $AH$  and  $CH$  intersect segments  $BC$  and  $AB$  in points  $A_1$  and  $C_1$  respectively. The segments  $BH$  and  $A_1C_1$  meet at point  $D$ . Let  $P$  be the midpoint of the segment  $BH$ . Let  $D'$  be the reflection of the point  $D$  in  $AC$ . Prove that quadrilateral  $APCD'$  is cyclic.

(Matko Ljulj)

**First solution.** We shall prove that  $D$  is the orthocenter of triangle  $APC$ . From that the problem statement follows as

$$\begin{aligned} \angle AD'C &= \angle ADC = 180^\circ - \angle DAC - \angle DCA = (90^\circ - \angle DAC) + (90^\circ - \angle DCA) = \\ &= \angle PCA + \angle PAC = 180^\circ - \angle APC. \end{aligned}$$

We can note that quadrilateral  $BA_1HC_1$  is cyclic. Lines  $BA_1$  and  $C_1H$  intersect in  $C$ , lines  $BC_1$  and  $A_1H$  intersect in  $A$ , lines  $BH$  and  $C_1A_1$  intersect in  $D$ , and point  $P$  is the circumcenter of  $BA_1HC_1$ . So by the corollary of the Brocard's theorem point  $D$  is indeed the orthocenter of triangle  $APC$  as desired.

**Second solution.** Denote by  $B_1$  the orthogonal projection of  $B$  on  $AC$ . By cyclic quadrilaterals  $B_1C_1PA_1$  (Euler's circle),  $HA_1CB_1$ ,  $AC_1A_1C$  and  $C_1HB_1A$  we get the following equations:

$$\begin{aligned} \angle A_1PB_1 &= \angle DC_1B_1 \\ \angle A_1B_1P &= \angle A_1CC_1 = \angle A_1AC_1 = \angle DB_1C_1. \end{aligned}$$

From these equalities we get that triangles  $B_1PA_1$  and  $B_1C_1D$  are similar, which implies

$$\frac{|B_1D|}{|B_1A_1|} = \frac{|B_1C_1|}{|B_1P|} \implies |B_1A_1| \cdot |B_1C_1| = |B_1D| \cdot |B_1P|.$$

Analogously, using cyclic quadrilateral  $ABA_1B_1$  and  $C_1BCB_1$  we get the following angle equations:

$$\begin{aligned} \angle B_1AC_1 &= 180^\circ - \angle B_1A_1B = \angle B_1A_1C \\ \angle AB_1C_1 &= 180^\circ - \angle C_1B_1C = \angle CBA = 180^\circ - \angle A_1B_1A = \angle A_1B_1C. \end{aligned}$$

From these equalities we get that triangles  $B_1AC_1$  and  $B_1AC$  are similar so

$$\frac{|B_1C_1|}{|B_1C|} = \frac{|AB_1|}{|A_1B_1|} \implies |B_1A_1| \cdot |B_1C_1| = |B_1A| \cdot |B_1C|.$$

Thus we get  $|B_1D'| \cdot |B_1P| = |B_1D| \cdot |B_1P| = |B_1A_1| \cdot |B_1C_1| = |B_1A| \cdot |B_1C|$  so by the reverse of the power of the point theorem the quadrilateral  $APCD'$  is cyclic as desired.

**Problem 3.** Prove that the following inequality holds for all positive real numbers  $a, b, c, d, e$  and  $f$ :

$$\sqrt[3]{\frac{abc}{a+b+d}} + \sqrt[3]{\frac{def}{c+e+f}} < \sqrt[3]{(a+b+d)(c+e+f)}.$$

(Dimitar Trenevski)

**Solution.** The inequality is equivalent to

$$\sqrt[3]{\frac{abc}{(a+b+d)^2(c+e+f)}} + \sqrt[3]{\frac{def}{(a+b+d)(c+e+f)^2}} < 1.$$

By AM-GM inequality we have

$$\sqrt[3]{\frac{abc}{(a+b+d)^2(c+e+f)}} \leq \frac{1}{3} \left( \frac{a}{a+b+d} + \frac{b}{a+b+d} + \frac{c}{c+e+f} \right),$$

$$\sqrt[3]{\frac{def}{(a+b+d)(c+e+f)^2}} \leq \frac{1}{3} \left( \frac{d}{a+b+d} + \frac{e}{c+e+f} + \frac{f}{c+e+f} \right).$$

Adding the inequalities we get

$$\sqrt[3]{\frac{abc}{(a+b+d)^2(c+e+f)}} + \sqrt[3]{\frac{def}{(a+b+d)(c+e+f)^2}} \leq \frac{1}{3} \left( \frac{a+b+d}{a+b+d} + \frac{c+e+f}{c+e+f} \right) = \frac{2}{3} < 1,$$

as desired.

**Problem 4.** Olja writes down  $n$  positive integers  $a_1, a_2, \dots, a_n$  smaller than  $p_n$  where  $p_n$  denotes the  $n$ -th prime number. Oleg can choose two (not necessarily different) numbers  $x$  and  $y$  and replace one of them with their product  $xy$ . If there are two equal numbers Oleg wins. Can Oleg guarantee a win?

(Matko Ljulj)

**Solution.** For  $n = 1$ , Oleg won't be able to write 2 equal numbers on the board as there will be only one number written on the board. We shall now consider the case  $n > 2$ .

Let's note that as all the numbers are strictly smaller than  $p_n$  we have all their prime factors are from the set  $\{p_1, p_2, \dots, p_{n-1}\}$ , so there are at most  $n - 1$  of them in total. We will represent each number  $a_1, a_2, \dots, a_n$  by the ordered  $(n - 1)$ -tuple of non-negative integers in the following way if  $a_i = p_1^{\alpha_{i,1}} \cdot p_2^{\alpha_{i,2}} \cdot \dots \cdot p_{n-1}^{\alpha_{i,(n-1)}}$ , then we assign  $v_i = (\alpha_{i,1}, \alpha_{i,2}, \dots, \alpha_{i,(n-1)})$ , for all  $i \in \{1, 2, \dots, n\}$ .

Let's consider the following system of equations:

$$\begin{aligned} \alpha_{1,1}x_1 + \alpha_{2,1}x_2 + \dots + \alpha_{n,1}x_n &= 0 \\ \alpha_{1,2}x_1 + \alpha_{2,2}x_2 + \dots + \alpha_{n,2}x_n &= 0 \\ &\dots \\ \alpha_{1,(n-1)}x_1 + \alpha_{2,(n-1)}x_2 + \dots + \alpha_{n,(n-1)}x_n &= 0 \end{aligned}$$

There is a trivial solution  $x_1 = x_2 = \dots = x_n = 0$ . But as this system has less equalities than variables we can deduce that it has infinitely many solutions in the set of rational numbers (as all the coefficients are rational). Let  $(y_1, y_2, \dots, y_n)$  be a not trivial solution (so the solution in which not all of  $y_i$  equal 0). Then we can rewrite the initial system using  $a_1, a_2, \dots, a_n$ :

$$\begin{aligned} \prod_{i=1}^n a_i^{y_i} &= \prod_{i=1}^n p_1^{\alpha_{i,1}y_i} \cdot p_2^{\alpha_{i,2}y_i} \cdot \dots \cdot p_{n-1}^{\alpha_{i,(n-1)}y_i} = \prod_{j=1}^{n-1} p_j^{\alpha_{1,j}y_1 + \alpha_{2,j}y_2 + \dots + \alpha_{n,j}y_n} = \prod_{j=1}^{n-1} p_j^0 = 1 \\ &\implies \prod_{i=1}^n a_i^{y_i} = 1. \end{aligned}$$

Considering the numbers  $y_1, y_2, \dots, y_n$  as rational numbers in which the respective nominator and denominator are coprime, Denote by  $L$  the lowest common multiplier of their denominators. Taking the  $L$ -th power of the upper equality we get integer exponents in the upper equation (which don't have a common factor). Furthermore, WLOG we can assume that  $a_1, a_2, \dots, a_k$  are those elements  $a_i$  whose exponents are negative and numbers  $a_{k+1}, a_{k+2}, \dots, a_{k+l}$  are

those elements with positive exponent (for some  $k, l \in \mathbb{N}, k+l \leq n$ ). Then, when we shift all  $a_i$ -s with negative exponent to the opposite side of the equation and when those with zero exponent get ruled out we get that the following equality

$$\prod_{i=1}^k a_i^{r_i} = \prod_{i=k+1}^l a_i^{r_i} \quad (1)$$

holds for some positive integers  $r_1, r_2, \dots, r_{k+l}$  for which  $D(r_1, r_2, \dots, r_{k+l}) = 1$  and for some numbers  $a_1, a_2, \dots, a_{k+l}$ . (We can note that there is at least one number  $a_i$  on both sides of the equality otherwise we have only ones on the board.)

We shall prove that there is a sequence of transformations by which using this relation we will get two equal numbers among  $a_1, a_2, \dots, a_n$ .

**Lemma 1.** *Let  $(a, b) \in \mathbb{N}^2$  and  $(x_1, x_2) \in \mathbb{N}^2$  be such that  $GCD(x_1, x_2) = 1$ . Then there exists a sequence of transformations which replaces the numbers  $(a, b)$  with  $(a', b')$ , where one of these numbers  $a', b'$  is equal to  $a^{x_1} b^{x_2}$ .*

*Proof.* We'll prove this by induction on  $x_1 + x_2$ , for all  $(a, b) \in \mathbb{N}^2$ . As the basis consider  $x_1 + x_2 = 2 \implies x_1 = x_2 = 1$ . The number  $ab$  we can get by applying transformation  $(a, b) \rightarrow (a, ab)$ .

Let's assume that the claim holds for all  $(x_1, x_2)$  such that  $x_1 + x_2 < n$ , and for all  $(a, b)$ . Let's take some numbers  $(x_1, x_2)$  such that  $x_1 + x_2 = n$  and some arbitrary numbers  $(a, b)$ . If  $x_1 = x_2$  is satisfied, since  $x_1$  and  $x_2$  are coprime, we could conclude that both numbers are equal to 1, but we have already proved this case in basis. Let's assume  $x_1 \neq x_2$ . WLOG  $x_1 > x_2$ . Then we apply the transformation  $(a, b) \rightarrow (a, ab)$ , and then apply the induction hypothesis on numbers  $(a, ab)$  and  $(x_1 - x_2, x_2)$ :

$$(a, b) \rightarrow (a, ab) \rightarrow (\gamma, a^{x_1 - x_2} (ab)^{x_2}) = (\gamma, a^{x_1} b^{x_2}),$$

where  $\gamma$  is some positive integer, what we wanted to prove. □

**Lemma 2.** *Let  $k \in \mathbb{N}$ ,  $(b_1, b_2, \dots, b_k) \in \mathbb{N}^k$  and  $(x_1, x_2, \dots, x_k) \in \mathbb{N}^k$ . Then there exists sequence of transformations which instead of numbers  $(b_1, b_2, \dots, b_k)$  writes down numbers  $(b'_1, b'_2, \dots, b'_k)$  such that one of those numbers is equal to*

$$(b_1^{x_1} b_2^{x_2} \dots b_k^{x_k})^{\frac{1}{d}},$$

where  $d$  denotes greatest common divisor of numbers  $x_1, x_2, \dots, x_k$ .

*Proof.* Intuitively, this lemma is just *Lemma 1* repeated  $(k-1)$  times.

We'll prove this by induction on  $k$ , for all  $b_1, b_2, \dots, b_k$  and  $x_1, x_2, \dots, x_k$ . In the basis, for  $k=1$ , it holds  $d = x_1$ , so it we don't have to do any transformation to reach desired situation.

Let's assume that the claim holds for some  $k \in \mathbb{N}$ . Let's take arbitrary  $(b_1, b_2, \dots, b_k, b_{k+1})$  and  $(x_1, x_2, \dots, x_k, x_{k+1})$ . Then we apply *Lemma 1* on numbers  $(b_k, b_{k+1})$  and  $(x'_k, x'_{k+1})$ , where  $x'_k = \frac{x_k}{d_1}$ ,  $x'_{k+1} = \frac{x_{k+1}}{d_1}$ ,  $d_1 = GCD(x_k, x_{k+1})$ , and then we apply the induction hypothesis on numbers  $(b_1, b_2, \dots, b_k^{x'_k} b_{k+1}^{x'_{k+1}})$  and  $(x_1, x_2, \dots, x_{k-1}, d_1)$ :

$$(b_1, b_2, \dots, b_k, b_{k+1}) \rightarrow (b_1, b_2, \dots, b_{k-1}, \gamma_k, b_k^{x'_k} b_{k+1}^{x'_{k+1}}) \rightarrow (\gamma_1, \gamma_2, \dots, \gamma_k, (b_1^{x_1} b_2^{x_2} \dots b_{k-1}^{x_{k-1}} (b_k^{x'_k} b_{k+1}^{x'_{k+1}})^{d_1})^{\frac{1}{d_2}}),$$

where  $\gamma_1, \gamma_2, \dots, \gamma_k$  are some positive integers and  $d_2 = GCD(x_1, x_2, \dots, x_{k-1}, d_1) = GCD(x_1, x_2, \dots, x_{k-1}, x_k, x_{k+1}) = d$ . Notice that last number in upper relation is the one we wanted to get. □

**Lemma 3.** *Let  $(a, b) \in \mathbb{N}^2$  and  $(x_1, x_2) \in \mathbb{N}^2$  such that  $GCD(x_1, x_2) = 1$ . Then there exists sequence of transformations which instead of numbers  $(a, b)$  writes down numbers  $(a', b')$  for which it is satisfied  $a'/b' = a^{x_1}/b^{x_2}$ .*

*Proof.* We'll prove this by induction on  $x_1 + x_2$ , for all  $(a, b) \in \mathbb{N}^2$ . In the basis is  $x_1 + x_2 = 2 \implies x_1 = x_2 = 1$ , so we don't have to do any transformation to reach desired situation.

Let's assume that the claim hold for all  $(x_1, x_2)$  such that  $x_1 + x_2 < n$ , and for all  $(a, b)$ . Let's take some numbers  $(x_1, x_2)$  such that  $x_1 + x_2 = n$  and arbitrary numbers  $(a, b)$ .

- If one of the numbers  $x_1$  and  $x_2$  is even (WLOG  $x_1$  is even): we apply transformation  $(a, b) \rightarrow (a^2, b)$ , and then we apply induction hypothesis on numbers  $(a^2, b)$  and  $(\frac{x_1}{2}, x_2)$ .
- Both numbers  $x_1$  and  $x_2$  are odd, and they are equal: then they are both equal to 1, which we have already solved in the basis.
- Numbers  $x_1$  and  $x_2$  are odd and distinct (WLOG  $x_1 > x_2$ ): we make following transformations  $(a, b) \rightarrow (a, ab) \rightarrow (a^2, ab)$ , and then we apply induction hypothesis on numbers  $(a^2, ab)$  and  $(\frac{x_1+x_2}{2}, x_2)$ :

$$(a, b) \rightarrow (a, ab) \rightarrow (a^2, ab) \rightarrow (c \cdot (a^2)^{\frac{x_1+x_2}{2}}, c \cdot (ab)^{x_2}) = ((a^{x_2} c) \cdot a^{x_1}, (a^{x_2} c) \cdot b^{x_2}),$$

where  $c$  is some positive integer, what we wanted to prove. □

In the equality (1), let  $d_1 = GCD(r_1, r_2, \dots, r_k)$ ,  $d_2 = GCD(r_{k+1}, r_{k+2}, \dots, r_{k+l})$ ,  $z_i = \frac{r_i}{d_1}$ ,  $\forall i \in \{1, 2, \dots, k\}$ ,  $z_i = \frac{r_i}{d_2}$ ,  $\forall i \in \{k+1, k+2, \dots, k+l\}$ . As well let  $A$  be the left hand side of the equality (1), and let  $B$  be the right hand side. Let  $A' = A^{\frac{1}{d_1}}$  and  $B' = B^{\frac{1}{d_2}}$ . We want to do such transformations that we get  $x$  i  $y$  which will have same ratio as  $A$  and  $B$ . If we apply *Lemma 2* on the numbers  $(a_1, a_2, \dots, a_k)$  and  $(z_1, z_2, \dots, z_k)$ ; we get (among other numbers we get) the number  $A'$ . As well applying the same lemma on the numbers  $(a_{k+1}, a_{k+2}, \dots, a_{k+l})$  and  $(z_{k+1}, z_{k+2}, \dots, z_{k+l})$ , we will get the number  $B'$  on the board.

Numbers  $d_1$  and  $d_2$  are coprime (otherwise there would be some prime  $p$  which would divide  $d_1$  and  $d_2$  which would imply it divides  $r_1, r_2, \dots, r_{k+l}$  as well which is in contradiction to the assumption they do not have a common factor). So we can apply *Lemma 3* on the numbers  $(A', B')$  and  $(d_1, d_2)$ . Now we get two numbers with the same ratio as  $A$  i  $B$ . But as by (1) we have  $A = B$ , we get 2 equal numbers on the board.

Thus Oleg can guarantee a win for any  $n > 1$ .

**Comment:** We can get to the relation (1) by concluding that the set  $\{v_1, v_2, \dots, v_n\}$  is linearly dependant subset of  $(n-1)$ -dimensional space  $\mathbb{Q}^{n-1}$ .

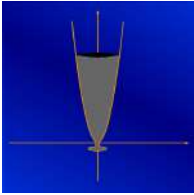

2<sup>ND</sup> EUROPEAN MATHEMATICAL CUP  
7<sup>th</sup> December 2013–15<sup>th</sup> December 2013  
Junior Category



**Problem 1.** For a positive integer  $m$  let  $m?$  be the product of first  $m$  prime numbers. Determine if there exist positive integers  $m$  and  $n$  with the following property:

$$m? = n(n+1)(n+2)(n+3).$$

(Matko Ljulj)

**Problem 2.** Let  $P$  be a point inside a triangle  $ABC$ . A line through  $P$  parallel to  $AB$  meets  $BC$  and  $CA$  at points  $L$  and  $F$ , respectively. A line through  $P$  parallel to  $BC$  meets  $CA$  and  $BA$  at points  $M$  and  $D$  respectively, and a line through  $P$  parallel to  $CA$  meets  $AB$  and  $BC$  at points  $N$  and  $E$  respectively. Prove

$$(PDBL) \cdot (PECM) \cdot (PFAN) = 8 \cdot (PFM) \cdot (PEL) \cdot (PDN),$$

where  $(XYZ)$  and  $(XYZW)$  denote the area of the triangle  $XYZ$  and the area of quadrilateral  $XYZW$ .

(Steve Dinh)

**Problem 3.** We are given a combination lock consisting of 6 rotating discs. Each disc consists of digits  $0, 1, 2, \dots, 9$ , in that order (after digit 9 comes 0). Lock is opened by exactly one combination. A move consists of turning one of the discs one digit in any direction and the lock opens instantly if the current combination is correct. Discs are initially put in the position 000000, and we know that this combination is not correct.

- What is the least number of moves necessary to ensure that we have found the correct combination?
- What is the least number of moves necessary to ensure that we have found the correct combination, if we know that none of the combinations 000000, 111111, 222222,  $\dots$ , 999999 is correct?

(Ognjen Stipetić, Grgur Valentić)

**Problem 4.** Let  $a, b, c$  be positive real numbers satisfying

$$\frac{a}{1+b+c} + \frac{b}{1+c+a} + \frac{c}{1+a+b} \geq \frac{ab}{1+a+b} + \frac{bc}{1+b+c} + \frac{ca}{1+c+a}.$$

Prove

$$\frac{a^2 + b^2 + c^2}{ab + bc + ca} + a + b + c + 2 \geq 2(\sqrt{ab} + \sqrt{bc} + \sqrt{ca}).$$

(Dimitar Trenevski)

*Time allowed: 240 minutes.*

*Each problem is worth 10 points.*

*Calculators are not allowed.*

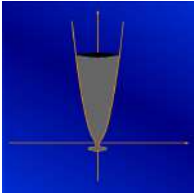

## Problems and Solutions

**Problem 1.** For a positive integer  $m$  let  $m^?$  be the product of first  $m$  prime numbers. Determine if there exist positive integers  $m$  and  $n$  with the following property:

$$m^? = n(n+1)(n+2)(n+3).$$

(Matko Ljulj)

**Solution.** Such numbers don't exist.

Let's assume the contrary i.e. there are such  $m$  and  $n$ .

We can note that there is only one prime divisible by 2 and that it 2 itself thus  $m^?$  isn't divisible by 4. On the other hand, the product  $n(n+1)(n+2)(n+3)$  is product of 4 consecutive integers so two of them are even making the product divisible by 4.

Thus equality  $m^? = n(n+1)(n+2)(n+3)$  gives us a contradiction as  $LHS$  is not divisible by 4 while  $RHS$  is.

**Problem 2.** Let  $P$  be a point inside a triangle  $ABC$ . A line through  $P$  parallel to  $AB$  meets  $BC$  and  $CA$  at points  $L$  and  $F$ , respectively. A line through  $P$  parallel to  $BC$  meets  $CA$  and  $BA$  at points  $M$  and  $D$  respectively, and a line through  $P$  parallel to  $CA$  meets  $AB$  and  $BC$  at points  $N$  and  $E$  respectively. Prove

$$(PDBL) \cdot (PECM) \cdot (PFAN) = 8 \cdot (PFM) \cdot (PEL) \cdot (PDN),$$

where  $(XYZ)$  and  $(XYZW)$  denote the area of the triangle  $XYZ$  and the area of quadrilateral  $XYZW$ .

(Steve Dinh)

**Solution.**

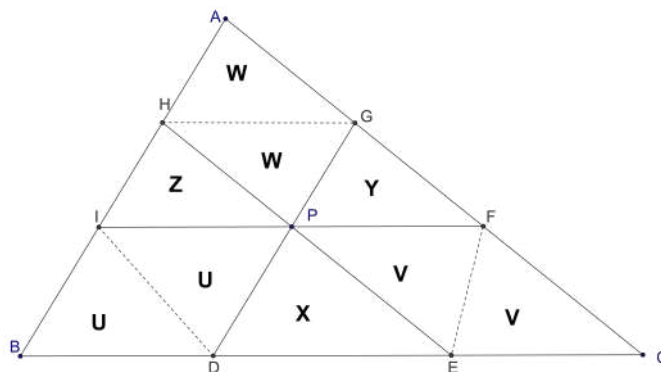

Let's denote the areas as on the sketch.

The problem is equivalent to

$$U \cdot V \cdot W = X \cdot Y \cdot Z.$$

Let  $x$  and  $y$  be lengths of altitudes from  $I$  and  $D$  in the triangle  $BID$  and let  $a$  and  $b$  be lengths of sides  $BI$  and  $BD$ .

We can deduce

$$X = (PED) = \frac{1}{2} \cdot a \cdot y \cdot \frac{BC}{BA},$$

$$Z = (PIH) = \frac{1}{2} \cdot b \cdot x \cdot \frac{BA}{BC} \text{ and}$$

$$U = (BID) = \frac{1}{2} \cdot a \cdot x = \frac{1}{2} \cdot b \cdot y$$

This gives  $U^2 = X \cdot Z$ . Analogously we get  $W^2 = Y \cdot Z$  and  $V^2 = X \cdot Y$ . Multiplying all three equalities we get the desired equation.

**Second solution.** Let's denote the areas of triangles  $PEL$ ,  $PFM$ ,  $PDN$  as  $P_A$ ,  $P_B$ ,  $P_C$  respectively and let's denote the areas of quadrilaterals  $PFAN$ ,  $PDBL$ ,  $PECM$  as  $Q_A$ ,  $Q_B$ ,  $Q_C$  respectively. We want to prove  $Q_A Q_B Q_C = 8P_A P_B P_C$ . Triangles  $PEL$ ,  $PFM$ , and  $PDN$  are similar to the triangle  $ABC$  (they have respective pairs of sides on parallel lines). Let's denote the respective similarity coefficients as  $k_A, k_B, k_C$ . As triangles  $PEL$ ,  $PFM$ , and  $PDN$  are in the interior of  $ABC$ , all those coefficients are less than 1.

Triangle  $ENB$  is similar to the triangle  $ABC$ . Its similarity coefficient is

$$\frac{EN}{AC} = \frac{EF + FN}{AC} = \frac{EF}{AC} + \frac{FN}{AC} = k_A + k_C.$$

From all these similarity relations we get area relations. Namely:

$$P_A : P_B = (P_A : (ABC)) : (P_B : (ABC)) = \left(\frac{k_A}{k_B}\right)^2 \implies P_A = \left(\frac{k_A}{k_B}\right)^2 P_B,$$

$$P_C : P_B = (P_C : (ABC)) : (P_B : (ABC)) = \left(\frac{k_C}{k_B}\right)^2 \implies P_C = \left(\frac{k_C}{k_B}\right)^2 P_B.$$

Using this we get:

$$(P_A + P_C + Q_B) : P_B = (ENB) : (PFM) = (k_A + k_C)^2 : (k_B)^2$$

$$\implies P_A + P_C + Q_B = \frac{k_A^2 + 2k_A k_C + k_C^2}{k_B^2} P_B = \frac{k_A^2}{k_B^2} P_B + \frac{2k_A k_C}{k_B^2} P_B + \frac{k_C^2}{k_B^2} P_B = P_A + \frac{2k_A k_C}{k_B^2} P_B + P_C$$

$$\implies Q_B = \frac{2k_A k_C}{k_B^2} P_B.$$

Similarly by the same process applied to  $FLC$  and  $MDA$  we get  $Q_C = \frac{2k_B k_A}{k_C^2} P_C$  i  $Q_A = \frac{2k_C k_B}{k_A^2} P_A$ . Multiplying what we got we have

$$Q_A Q_B Q_C = \frac{2k_C k_B}{k_A^2} P_A \frac{2k_A k_C}{k_B^2} P_B \frac{2k_B k_A}{k_C^2} P_C = 8 \frac{k_A^2 k_B^2 k_C^2}{k_A^2 k_B^2 k_C^2} P_A P_B P_C = 8P_A P_B P_C,$$

Q.E.D.

**Problem 3.** We are given a combination lock consisting of 6 rotating discs. Each disc consists of digits  $0, 1, 2, \dots, 9$ , in that order (after digit 9 comes 0). Lock is opened by exactly one combination. A move consists of turning one of the discs one digit in any direction and the lock opens instantly if the current combination is correct. Discs are initially put in the position 000000, and we know that this combination is not correct.

- What is the least number of moves necessary to ensure that we have found the correct combination?
- What is the least number of moves necessary to ensure that we have found the correct combination, if we know that none of the combinations 000000, 111111, 222222,  $\dots$ , 999999 is correct?

(Ognjen Stipetić, Grgur Valentić)

**Solution.** We will solve the subproblems separately.

- In order to ensure that we have discovered the code we need to check all but one of the combinations (as otherwise all unchecked codes can be the correct combination). Total number of combinations is  $10^6$  (as each of the 6 discs consists of 10 digits). As we are given that 000000 is not the correct combination we require at least  $10^6 - 2$  moves. We will now prove that there is a sequence of  $10^6 - 2$  moves each checking a different combination. We will prove this by induction on the number of wheels where the case  $n = 6$  is given in the problem.

CLAIM: For a lock of  $n$  wheels and for any starting combination of the wheels  $(a_1 a_2 \dots a_n)$  there is a sequence of moves checking all  $10^n$  combinations exactly once, for all  $n \in \mathbb{N}$ .

BASIS: For  $n = 1$  and for the starting combination  $(a)$ , we consider the sequence of moves

$$a \rightarrow a + 1 \rightarrow a + 2 \rightarrow \dots \rightarrow 9 \rightarrow 0 \rightarrow 1 \rightarrow \dots \rightarrow a - 1$$

ASSUMPTION: The induction claim is valid for some  $n \in \mathbb{N}$ .

STEP: We will prove that the claim holds for  $n+1$  as well. We consider an arbitrary starting state  $(a_1 a_2 \dots a_n a_{n+1})$ . By the induction hypothesis there is a sequence of moves such that starting from this state we can check all the states showing  $a_{n+1}$  on the last disc. Let this sequence of moves end with the combination  $(b_1 b_2 \dots b_n a_{n+1})$ .

Now we make the move  $(b_1 b_2 \dots b_n a_{n+1}) \rightarrow (b_1 b_2 \dots b_n a_{n+1} + 1)$  (if  $a_{n+1}$  is 9, then we turn the disc to show 0).

We continue in the same way applying the induction hypothesis on first  $n$  discs and the rotation the  $n+1$ -st disc. This way we get the sequence of moves

$$\begin{aligned} & (a_1 a_2 \dots a_n a_{n+1}) \rightarrow (b_1 b_2 \dots b_n a_{n+1}) \rightarrow (b_1 b_2 \dots b_n a_{n+1} + 1) \\ & \rightarrow (c_1 c_2 \dots c_n a_{n+1} + 1) \rightarrow (c_1 c_2 \dots c_n a_{n+1} + 2) \\ & \dots \\ & \rightarrow (j_1 j_2 \dots j_n a_{n+1} - 2) \rightarrow (j_1 j_2 \dots j_n a_{n+1} - 1). \end{aligned}$$

This sequence checks each combination exactly once finishing the induction and proving our claim.

- b) As in the a) part, we conclude that we have to check all the combinations apart from 000000, 111111, ..., 999999 and we can be sure as to what is the solution before the move checking the last combination.

We denote the combination as *black* if the sum of its digits is even and *white* if that sum is odd. We can notice that all the combinations 000000, 111111, ..., 999999 are black and by each move we swap the color of the current combination.

Number of black combinations all of which we need to check at least once is  $\frac{10^6}{2} - 10$  while number of such white combinations is  $\frac{10^6}{2}$ .

As we are checking white combinations every second move, in order to check all  $\frac{10^6}{2}$  white combination we need at least  $2 \cdot \frac{10^6}{2} - 1 = 10^6 - 1$  moves, thus we need at least  $10^6 - 2$  moves to find the correct combination.

An example doing this in  $10^6 - 2$  moves has been given in part a).

**Problem 4.** Let  $a, b, c$  be positive real numbers satisfying

$$\frac{a}{1+b+c} + \frac{b}{1+c+a} + \frac{c}{1+a+b} \geq \frac{ab}{1+a+b} + \frac{bc}{1+b+c} + \frac{ca}{1+c+a}.$$

Prove

$$\frac{a^2 + b^2 + c^2}{ab + bc + ca} + a + b + c + 2 \geq 2(\sqrt{ab} + \sqrt{bc} + \sqrt{ca}).$$

(Dimitar Trenevski)

**Solution.** We start with the given condition:

$$\begin{aligned} & \frac{a}{1+b+c} + \frac{b}{1+c+a} + \frac{c}{1+a+b} \geq \frac{ab}{1+a+b} + \frac{bc}{1+b+c} + \frac{ca}{1+c+a} \iff \\ & \frac{a+ab+bc}{1+b+c} + \frac{b+bc+ca}{1+c+a} + \frac{c+ca+cb}{1+a+b} \geq \frac{ab+ac+bc}{1+a+b} + \frac{bc+ab+ca}{1+b+c} + \frac{ca+bc+ab}{1+c+a} \iff \\ & \frac{a(1+b+c)}{1+b+c} + \frac{b(1+c+a)}{1+c+a} + \frac{c(1+a+b)}{1+a+b} \geq \frac{ab+bc+ca}{1+a+b} + \frac{ab+bc+ca}{1+b+c} + \frac{ab+bc+ca}{1+c+a} \iff \\ & a+b+c \geq (ab+bc+ca) \left( \frac{1}{1+a+b} + \frac{1}{1+b+c} + \frac{1}{1+c+a} \right). \end{aligned}$$

Now using *Cauchy-Schwarz* inequality we get:

$$\left( \frac{1}{1+a+b} + \frac{1}{1+b+c} + \frac{1}{1+c+a} \right) (c(1+a+b) + a(1+b+c) + b(1+c+a)) \geq (\sqrt{a} + \sqrt{b} + \sqrt{c})^2.$$

Combining the last two inequalities we get:

$$\begin{aligned} & (a+b+c)(a+b+c+2(ab+bc+ca)) \geq \\ & \geq (ab+bc+ca) \left( \frac{1}{1+a+b} + \frac{1}{1+b+c} + \frac{1}{1+c+a} \right) (a+b+c+2(ab+bc+ca)) = \\ & = (ab+bc+ca) \left( \frac{1}{1+a+b} + \frac{1}{1+b+c} + \frac{1}{1+c+a} \right) (c(1+a+b) + a(1+b+c) + b(1+c+a)) \geq \\ & \geq (ab+bc+ca)(\sqrt{a} + \sqrt{b} + \sqrt{c})^2, \end{aligned}$$

which now by some algebraic manipulation gives:

$$\begin{aligned}(a+b+c)(a+b+c+2(ab+bc+ca)) &\geq (ab+bc+ca)(\sqrt{a}+\sqrt{b}+\sqrt{c})^2 \iff \\(a+b+c)^2+2(a+b+c)(ab+bc+ca) &\geq (ab+bc+ca)(a+b+c+2(\sqrt{ab}+\sqrt{bc}+\sqrt{ca})) \iff \\(a^2+b^2+c^2)+(2(a+b+c)+2)(ab+bc+ca) &\geq (ab+bc+ca)(a+b+c+2(\sqrt{ab}+\sqrt{bc}+\sqrt{ca})) \iff \\ \frac{a^2+b^2+c^2}{ab+bc+ca}+a+b+c+2 &\geq 2(\sqrt{ab}+\sqrt{bc}+\sqrt{ca}),\end{aligned}$$

where the last inequality is exactly the one we wanted to prove.

*Time allowed: 240 minutes.*

*Each problem is worth 10 points.*

*Calculators are not allowed.*

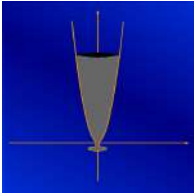

**2<sup>ND</sup> EUROPEAN MATHEMATICAL CUP**  
7<sup>th</sup> December 2013–15<sup>th</sup> December 2013  
Senior Category



**Problem 1.** In each field of a table there is a real number. We call such  $n \times n$  table *silly* if each entry equals the product of all the numbers in the neighbouring fields.

- Find all  $2 \times 2$  silly tables.
- Find all  $3 \times 3$  silly tables.

(Two fields of a table are neighbouring if they share a common side.)

(Borna Vukorepa)

**Problem 2.** *Palindrome* is a sequence of digits which doesn't change if we reverse the order of its digits. Prove that a sequence  $(x_n)_{n=0}^{\infty}$  defined as

$$x_n = 2013 + 317n$$

contains infinitely many numbers with their decimal expansions being palindromes.

(Stijn Cambie)

**Problem 3.** We call a sequence of  $n$  digits one or zero a *code*. Subsequence of a code is a *palindrome* if it is the same after we reverse the order of its digits. A palindrome is called *nice* if its digits occur consecutively in the code. (Code (1101) contains 10 palindromes, of which 6 are nice.)

- What is the least number of palindromes in a code?
- What is the least number of nice palindromes in a code?

(Ognjen Stipetić)

**Problem 4.** Given a triangle  $ABC$  let  $D, E, F$  be orthogonal projections from  $A, B, C$  to the opposite sides respectively. Let  $X, Y, Z$  denote midpoints of  $AD, BE, CF$  respectively. Prove that perpendiculars from  $D$  to  $YZ$ , from  $E$  to  $XZ$  and from  $F$  to  $XY$  are concurrent.

(Matija Bucić)

*Time allowed: 240 minutes.*

*Each problem is worth 10 points.*

*Calculators are not allowed.*

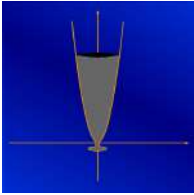

## Problems and Solutions

**Problem 1.** In each field of a table there is a real number. We call such  $n \times n$  table *silly* if each entry equals the product of all the number in the neighbouring fields.

- Find all  $2 \times 2$  silly tables.
- Find all  $3 \times 3$  silly tables.

(Two fields of a table are neighbouring if they share a common side.)

(Borna Vukorepa)

**Solution.** We solve the subproblems separately.

- Denote the numbers in the table as on the picture:

$a$	$b$
$c$	$d$

By the problem condition we have the following:

$$\begin{aligned} a &= bc \\ b &= ad \\ c &= ad \\ d &= bc. \end{aligned}$$

From here we can see  $a = bc = d$  and  $b = ad = c$ . When we apply this to the upper relations we get  $a = b^2$  and  $b = a^2$  and so  $a = b^2 = a^4 \iff a(a-1)(a^2+a+1) = 0$ . The real solutions to this problem are  $a = 0$  and  $a = 1$ . Now we can see that all  $2 \times 2$  silly tables are those with all element equal and furthermore equal to zero or one.

- Denote by  $a, b, c, d$  the elements in the table which have exactly three neighbours. We denote the remaining elements in terms of these and get the following table:

$ab$	$a$	$ad$
$b$	$abcd$	$d$
$bc$	$c$	$cd$

Let's assume that  $abcd = 0$ . This implies that the middle element is zero which further implies all its neighbours are zero and consequently every element in the table is zero. And thus only silly table under in this case is all zeros table.

Now assume that  $abcd \neq 0$ , i.e. none of the table elements is equal to zero. Using the remaining conditions we get:

$$a = (ab)(abcd)(ad) = a^3 b^2 d^2 c \iff a^2 b^2 d^2 c = 1,$$

Analogously we get  $a^2 b^2 c^2 d = 1$ ,  $a^2 c^2 d^2 b = 1$  i  $b^2 c^2 d^2 a = 1$  (we are allowed to divide by  $a, b, c, d$  as they are all non-zero). Equating the *LHS*s of these equations we get  $a = b = c = d$ . Inserting this in any of these equations we get  $a^7 = 1 \implies a = 1$ .

Thus all  $3 \times 3$  silly tables are all ones and all zeros tables.

**Problem 2.** *Palindrome* is a sequence of digits which doesn't change if we reverse the order of its digits. Prove that a sequence  $(x_n)_{n=0}^{\infty}$  defined as

$$x_n = 2013 + 317n$$

contains infinitely many numbers with their decimal expansions being palindromes.

(Stijn Cambie)

**First solution.** We will prove the following lemma providing two proofs:

**Lemma 1.** *There is infinitely many numbers divisible with 317 with their decimal expansions consisting only of ones.*

*Proof.* Considering the sequence 1, 11, 111, ... consisting of infinitely many numbers. This numbers have some residues modulo 317. By The Pigeonhole Principle there are at least two numbers in this sequence with the same residue modulo 317. Let the smaller of these two have  $l$  digits and larger  $k$ . Their difference is

$$\underbrace{111\dots 1}_{k \text{ times}} - \underbrace{111\dots 1}_{l \text{ times}} = \underbrace{111\dots 1}_{(k-l) \text{ times}} \underbrace{000\dots 0}_{l \text{ times}}$$

divisible by 317. It will also remain divisible by 317 if we divide it by  $10^l$  (as 10 and 317 are coprime). This way we get a number consisting only of ones divisible by 317. Let's denote the number of its digits by  $k$ . We get infinitely many such numbers by considering numbers consisting of  $k, 2k, 3k, \dots$  ones.  $\square$

*Proof.* As 317 is prime, and as it is coprime with 10 by Fermat's Little Theorem

$$10^{316} \equiv 1 \pmod{317} \implies 317 \mid 10^{316m} - 1, \forall m \in \mathbb{Z}, m \geq 1.$$

As 9 is coprime with 317 as well, numbers of the form  $\frac{1}{9}(10^{316m} - 1)$ ,  $m \in \mathbb{Z}, m \geq 1$  have the property we desire.  $\square$

Continuing with the solution we can note that some integer  $m$  is in the sequence  $(x_n)_{n=0}^\infty$  if and only if  $m \geq 2013$  and  $m \equiv 2013 \equiv 111 \pmod{317}$ . Let  $(y_n)_{n=0}^\infty$  be a sequence of infinitely many positive integers with their decimal expansions consisting only of ones and each being divisible by 317 (we are using our lemma here). Now numbers

$$1000y_n + 111$$

are in the sequence (as they have the remainder 111 modulo 317) and their decimal expansions are palindromes. Thus there is infinitely many members of the sequence  $(x_n)_{n=0}^\infty$  whose decimal expansions are palindromes.

**Second solution.** We will prove the generalised version of the problem for the sequence  $(x_n)_{n=0}^\infty$  defined as  $x_n = a + nb$ , where  $a, b$  are arbitrary positive integers with the property that  $b$  is coprime with 10. The problem is a special case of this for  $a = 2013$  i  $b = 317$ .

We define the sequence  $(y_n)_{n=0}^\infty$  in the following way:  $y_n = 10^{n\varphi(b)}$ . Using The Euler's Theorem,  $y_n \equiv 1 \pmod{b}$ . Considering the number  $1 + y_n + y_n^2 + \dots + y_n^{a-1}$ , its decimal expansion is:

$$1 \underbrace{000\dots 0}_{n\varphi(b)-1 \text{ times}} 1 \underbrace{000\dots 0}_{n\varphi(b)-1 \text{ times}} \dots 1 \underbrace{000\dots 0}_{n\varphi(b)-1 \text{ times}} 1$$

where the digit one is repeated  $a$  times. It is clear now that the decimal expansion of this number is a palindrome. On the other hand  $1 + y_n + y_n^2 + \dots + y_n^{a-1} \equiv 1 + 1 + \dots + 1 = a \pmod{b}$ , so this number is in the sequence  $(x_n)_{n=0}^\infty$ , for each number  $n$ . Thus we have found infinitely many members of the sequence  $(x_n)_{n=0}^\infty$  with their decimal expansions being palindromes as we wanted.

**Problem 3.** We call a sequence of  $n$  digits one or zero a *code*. Subsequence of a code is a *palindrome* if it is the same after we reverse the order of its digits. A palindrome is called *nice* if its digits occur consecutively in the code. (*Code (1101) contains 10 palindromes, of which 6 are nice.*)

- a) What is the least number of palindromes in a code?
- b) What is the least number of nice palindromes in a code?

(Ognjen Stipetić)

**Solution.** We will consider the two subproblems separately:

- a) Consider any code. Assume there is  $k$  digits one and  $n - k$  digits zero. We now transform this code into

$$\underbrace{111\dots 1}_{k \text{ puta}} \underbrace{000\dots 0}_{n-k \text{ puta}}$$

by preserving the order among same digits. Lets note that each palindrome consisting of same digits is in the initial code if and only if it is in the transformed code. The transformed code doesn't have a palindrome not consisting of same digits and thus the transformed code has less or equal palindromes than the initial one.

Thus we conclude that it is enough to consider only the codes starting with  $k$  digits one and ending in  $n - k$  zeros, for some  $k \in \{0, 1, \dots, n\}$ .

Let us fix a  $k \in \{0, 1, \dots, n\}$ . The code consisting of  $k$  ones and  $n - k$  zeros has  $2^k - 1 + 2^{n-k} - 1 = 2^k + 2^{n-k} - 2$  palindromes. We now seek  $k$  which minimizes this expression.

If  $n$  is even ( $n = 2m$ ), by the AM-GM inequality  $2^k + 2^{n-k} \geq 2 \cdot \sqrt{2^{k+n-k}} = 2^m + 2^m \implies$  the least possible number of palindromes in the code with  $2m$  digits is  $2^m + 2^m - 2 = 2^{m+1} - 2$ , and this number is clearly attained for the code with  $m$  digits one and ending in  $m$  digits zero.

If  $n$  is odd ( $n = 2m + 1$ ) we have the following inequality for each  $k \in \{0, 1, \dots, m - 1\}$ :

$$2^k + 2^{n-k} > 2^{k+1} + 2^{n-k-1} \quad (\iff 2^{n-k-1} > 2^k)$$

From this we also get  $2^k + 2^{n-k-1} < 2^{k-1} + 2^{n-k+1}$  for all  $k \in \{m + 1, m + 2, \dots, 2m + 1\}$ . So:

$$2^0 + 2^n > 2^1 + 2^{n-1} > \dots > 2^m + 2^{m+1} = 2^{m+1} + 2^m < 2^{m+2} + 2^{m-1} < \dots < 2^n + 2^0$$

Now it is clear that the least number of palindromes in the code with  $2m + 1$  digits is  $2^m + 2^{m+1} - 2$  and this number is attained by the code of  $m$  digits one and  $m + 1$  digits zero.

b) For  $n = 1$  we clearly see that the answer is 1. From now on we assume  $n \geq 2$ .

As well for simplicity of the write-up we will not consider the one-digit palindromes as nice as we know that each code of  $n$  digits consists of  $n$  one-digit palindromes, each of which is nice. So we will find the smallest possible number of multi-digit nice palindromes and we will add  $n$  to this number to get the desired solution.

As a last remark: in this part of the solution for brevity we will denote as palindromes only those that are nice by the definitions in the problem statement.

Code consisting of  $n$  digits 1 contains one  $n$ -digit palindrome, two  $(n - 1)$ -digit palindromes, ...,  $n - 2$  three digit palindromes and  $n - 1$  two digit palindromes. After summing up we get that this code has  $\frac{n(n-1)}{2}$  palindromes. Analogously the code consisting of  $n$  digits 0 contains the same number of palindromes.

We now consider the code which contains at least one digit one and at least one digit zero. Then each digit 1 except the rightmost one is the start of at least one palindrome (the sequence of digits starting with it and ending in the first digit one to the right of it is of the form  $100\dots 01$  and is thus a palindrome). Analogously we conclude that each digit 0 apart from the rightmost one is a start of at least one palindrome. As we have at least one digit 1 and one digit 0 we conclude that each code consists of at least  $n - 2$  palindromes (where we have deducted 2 for the rightmost digit 1 and 0).

By induction on  $n$  we will show that for each  $n \in \mathbb{N}, n \geq 2$  we can find a code with exactly  $n - 2$  palindromes. We can note that for  $n = 2, 3, 4$  this is possible as the examples are (10), (101), (1101). Now let's assume that the induction claim holds for some  $n \in \mathbb{N}, n \geq 4$ , and let  $(x_1 \dots x_n)$  be a code with exactly  $n - 2$  palindromes.

That code is certainly not (011...1) or (100...0) (similarly as in the case with all digits equal we conclude that these codes have  $\frac{(n-1)(n-2)}{2} > n - 2$  palindromes).

We now that each of the digits one/zero apart from the rightmost ones is the start of at least one palindrome. In order for total number of palindromes to be  $n - 2$  all such digits are starts of exactly one palindrome. As  $(x_1 \dots x_n) \neq (011\dots 1)$  and  $(x_1 \dots x_n) \neq (100\dots 0)$ , digit  $x_1$  is not the rightmost digit one/zero  $\implies x_1$  is the start of exactly one palindrome.

We now show that we can choose a digit  $x_0$  such that  $(x_0 x_1 x_2 \dots x_n)$  contains exactly  $n - 1$  palindromes. As there are  $n - 2$  palindromes  $(x_1 x_2 \dots x_n)$  we need to show that we can choose  $x_0$  such that  $x_0$  is a start of exactly one palindrome in  $(x_0 x_1 \dots x_n)$ . We know that  $x_0$  is a start of at least one palindrome so we actually only have to show it is a start of at most one palindromes.

Let's consider to which palindromes can  $x_0$  be a start:

- $(x_0 x_1)$  is a palindrome  $\iff x_0 = x_1$
- $(x_0 x_1 x_2)$  is a palindrome  $\iff x_0 = x_2$
- $(x_0 x_1 x_2 \dots x_k x_{k+1})$  is a palindrome, for some  $k \in \{2, 3, 4, \dots, n-1\}$   $\iff x_0 = x_{k+1}$  and  $(x_1 x_2 \dots x_k)$  is a palindrome

As there is exactly one palindrome for which  $x_1$  is the start we conclude there is at most one palindrome such that  $x_0$  is its start and it has the form as in the third case above. Thus there are at most three palindromes to which  $x_0$  can be the first digit as we have two options for the choice of  $x_0 \in \{0, 1\}$ . Thus, by The Pigeonhole Principle we can choose a digit such that  $x_0$  is a start of at most one palindrome, as desired.

Now using this and the remarks given before we have shown that the smallest possible number of nice palindromes with  $n$  digits is 1 (for  $n = 1$ ) and  $2n - 2$  (for  $n \geq 2$ ).

**Problem 4.** Given a triangle  $ABC$  let  $D, E, F$  be orthogonal projections from  $A, B, C$  to the opposite sides respectively. Let  $X, Y, Z$  denote midpoints of  $AD, BE, CF$  respectively. Prove that perpendiculars from  $D$  to  $YZ$ , from  $E$  to  $XZ$  and from  $F$  to  $XY$  are concurrent.

(Matija Bucić)

**First solution.** Let  $H$  be the orthocenter of the triangle  $ABC$ . We denote the midpoint of  $EF$  as  $P$ . As  $PZ$  is a midline of the triangle  $CEF$  we have  $PZ \parallel AC$ , and as  $YH$  is perpendicular to  $AC$ , we get that  $YH$  is perpendicular to  $PZ$ . Analogously we conclude that the line  $ZH$  is perpendicular to  $PY$ , so  $H$  has to be the orthocenter of the triangle  $PYZ$ . From this we can deduce that the line  $PH$  is perpendicular to  $YZ$ , and thus  $PH$  is parallel to the line perpendicular to  $YZ$  which passes through  $D$ .

Now denote as  $N$  the tangency point of the incircle of the triangle  $DEF$  with its side  $EF$ . Let  $N'$  be the point symmetric to  $N$  with respect to  $H$  and let  $M$  be the tangency point of the  $D$ -excircle of the triangle  $DEF$  with the side  $EF$ . As  $P$  is the midpoint of  $NM$  and as is  $H$  the midpoint of  $NN'$ , we have that  $PH$  is parallel to  $N'M$ . As we know that  $M$  is the map of the point  $N'$  under the homothety with centre  $D$  which maps the incircle to excircle of the triangle  $DEF$ , we can conclude that  $D, N'$  and  $M$  are collinear.

We can now conclude that the line perpendicular to  $YZ$  passing through  $D$  is parallel to  $PH$  while this line is parallel to  $N'M$ . As  $D$  lies on  $N'M$  we conclude that  $DM$  is the line through  $D$  perpendicular to  $YZ$ .

Analogously we can conclude that perpendiculars from  $E$  to  $XZ$  and from  $F$  to  $XY$  are lines joining vertices with the corresponding excircle tangency point of the triangle  $DEF$ . Using the Ceva's Theorem gives us the result.

*Remark:* The intersection of the lines connecting the vertices of the triangle respective tangency points intersect in the point which is called *Nagel's point* of the triangle (so we have proved that the three lines in the problem intersect in the Nagel's point of the triangle  $DEF$ ).

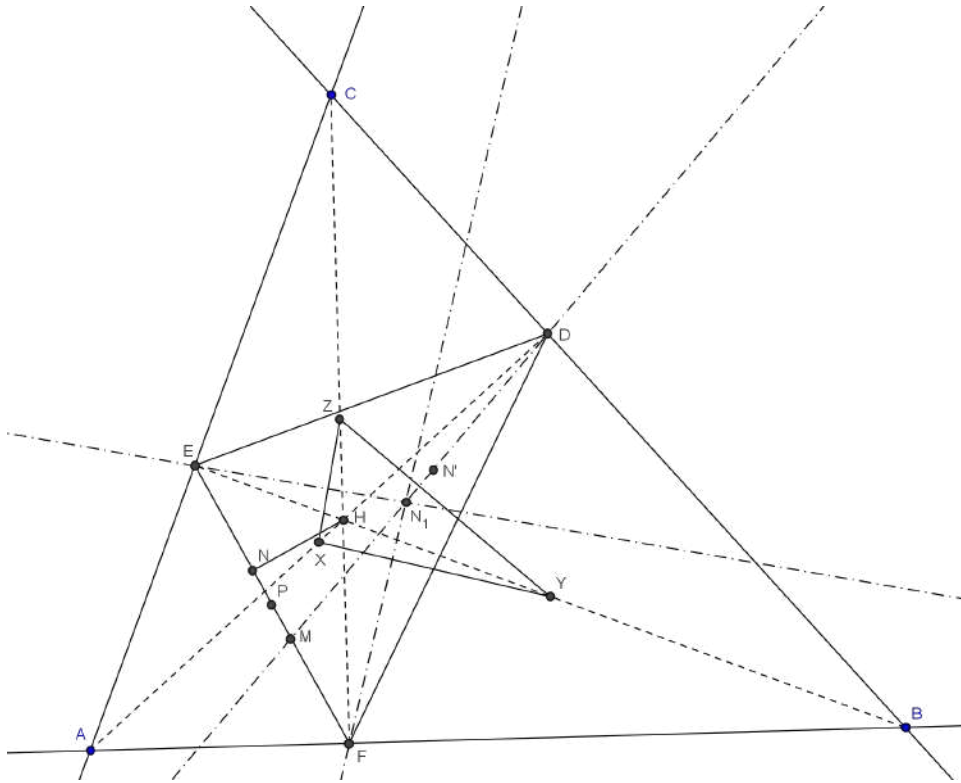

**Second solution.** By applying The Carnot's Theorem to the triangle  $XYZ$  and points  $D, E, F$ , three lines in the problem are concurrent if and only if:

$$FX^2 - FY^2 + DY^2 - DZ^2 + EZ^2 - EX^2 = 0 \tag{1}$$

In the triangle  $AFD$  and  $EFB$  lines  $\overline{FX}$  and  $\overline{FY}$  are medians, so

$$FX^2 = \frac{1}{4}(2AF^2 + 2FD^2 - AD^2)$$

$$FY^2 = \frac{1}{4}(2FB^2 + FE^2 - EB^2).$$

Noting that the other sides on the *LHS* of (1) are medians in the respective triangles we deduce:

$$\begin{aligned}
FX^2 - FY^2 + DY^2 - DZ^2 + EZ^2 - EX^2 &= \\
\frac{1}{4}[(2AF^2 + 2FD^2 - AD^2) - (2FB^2 + 2FE^2 - EB^2) + \\
+(2DB^2 + 2DE^2 - EB^2) - (2DC^2 + 2DF^2 - CF^2) + \\
+(2EC^2 + 2EF^2 - CF^2) - (2EA^2 + 2ED^2 - AD^2)] &= \\
\frac{1}{2}(AF^2 - FB^2 + DB^2 - DC^2 + EC^2 - EA^2).
\end{aligned}$$

From right-angled triangles *AFC* and *FBC* we get:

$$AF^2 - FB^2 = (AC^2 - FC^2) - (BC^2 - FC^2) = AC^2 - BC^2.$$

Applying this analogously to triangles *AEB*, *EBC*, *ADC*, *ADB* we get:

$$\begin{aligned}
FX^2 - FY^2 + DY^2 - DZ^2 + EZ^2 - EX^2 &= \\
\frac{1}{2}(AF^2 - FB^2 + DB^2 - DC^2 + EC^2 - EA^2) &= \\
\frac{1}{2}(AC^2 - BC^2 + AB^2 - AC^2 + BC^2 - AB^2) &= 0,
\end{aligned}$$

Q.E.D.

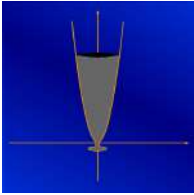

**3<sup>RD</sup> EUROPEAN MATHEMATICAL CUP**  
*6<sup>th</sup> December 2014–14<sup>th</sup> December 2014*  
Junior Category



**Problem 1.** Which of the following claims are true, and which of them are false? *If a fact is true you should prove it, if it isn't, find a counterexample.*

- Let  $a, b, c$  be real numbers such that  $a^{2013} + b^{2013} + c^{2013} = 0$ . Then  $a^{2014} + b^{2014} + c^{2014} = 0$ .
- Let  $a, b, c$  be real numbers such that  $a^{2014} + b^{2014} + c^{2014} = 0$ . Then  $a^{2015} + b^{2015} + c^{2015} = 0$ .
- Let  $a, b, c$  be real numbers such that  $a^{2013} + b^{2013} + c^{2013} = 0$  and  $a^{2015} + b^{2015} + c^{2015} = 0$ . Then  $a^{2014} + b^{2014} + c^{2014} = 0$ .

*(Matko Ljulj)*

**Problem 2.** In each vertex of a regular  $n$ -gon  $A_1A_2\dots A_n$  there is a unique pawn. In each step it is allowed:

- to move all pawns one step in the clockwise direction or
- to swap the pawns at vertices  $A_1$  and  $A_2$ .

Prove that by a finite series of such steps it is possible to swap the pawns at vertices:

- $A_i$  and  $A_{i+1}$  for any  $1 \leq i < n$  while leaving all other pawns in their initial place
- $A_i$  and  $A_j$  for any  $1 \leq i < j \leq n$  leaving all other pawns in their initial place.

*(Matija Bucić)*

**Problem 3.** Let  $ABC$  be a triangle. The external and internal angle bisectors of  $\angle CAB$  intersect side  $BC$  at  $D$  and  $E$ , respectively. Let  $F$  be a point on the segment  $BC$ . The circumcircle of triangle  $ADF$  intersects  $AB$  and  $AC$  at  $I$  and  $J$ , respectively. Let  $N$  be the mid-point of  $IJ$  and  $H$  the foot of  $E$  on  $DN$ . Prove that  $E$  is the incenter of triangle  $AHF$ .

*(Steve Dinh)*

**Problem 4.** Find all infinite sequences  $a_1, a_2, a_3, \dots$  of positive integers such that

- $a_{nm} = a_n a_m$ , for all positive integers  $n, m$ , and
- there are infinitely many positive integers  $n$  such that  $\{1, 2, \dots, n\} = \{a_1, a_2, \dots, a_n\}$ .

*(Matko Ljulj)*

*Time allowed: 240 minutes.*

*Each problem is worth 10 points.*

*Calculators are not allowed.*

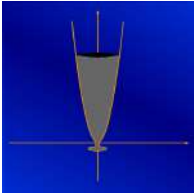

## Problems and Solutions

**Problem 1.** Which of the following claims are true, and which of them are false? *If a fact is true you should prove it, if it isn't, find a counterexample.*

- Let  $a, b, c$  be real numbers such that  $a^{2013} + b^{2013} + c^{2013} = 0$ . Then  $a^{2014} + b^{2014} + c^{2014} = 0$ .
- Let  $a, b, c$  be real numbers such that  $a^{2014} + b^{2014} + c^{2014} = 0$ . Then  $a^{2015} + b^{2015} + c^{2015} = 0$ .
- Let  $a, b, c$  be real numbers such that  $a^{2013} + b^{2013} + c^{2013} = 0$  and  $a^{2015} + b^{2015} + c^{2015} = 0$ . Then  $a^{2014} + b^{2014} + c^{2014} = 0$ .

(Matko Ljulj)

**Solution.** Firstly, we know that for every real number  $x$ ,  $x^2 \geq 0$  holds.

The key idea in this problem is to realize that the expression  $a^{2014} + b^{2014} + c^{2014}$  is a sum of squares (which are nonnegative numbers). Thus  $a^{2014} + b^{2014} + c^{2014} = 0 \iff a = b = c = 0$ .

- NO: It is sufficient to find three real numbers whose sum equals 0, and then take their 2013<sup>th</sup> roots. For example:  $a = \sqrt[2013]{1}$ ,  $b = \sqrt[2013]{2}$ ,  $c = \sqrt[2013]{-3}$ .
- YES: From the key idea we conclude  $a = b = c = 0$ , and then we conclude  $a^{2015} + b^{2015} + c^{2015} = 0 + 0 + 0 = 0$ .
- NO: Again we have to find a counterexample, for instance  $a = 1, b = 0, c = -1$ .

**Problem 2.** In each vertex of a regular  $n$ -gon  $A_1A_2\dots A_n$  there is a unique pawn. In each step it is allowed:

- to move all pawns one step in the clockwise direction or
- to swap the pawns at vertices  $A_1$  and  $A_2$ .

Prove that by a finite series of such steps it is possible to swap the pawns at vertices:

- $A_i$  and  $A_{i+1}$  for any  $1 \leq i < n$  while leaving all other pawns in their initial place
- $A_i$  and  $A_j$  for any  $1 \leq i < j \leq n$  leaving all other pawns in their initial place.

(Matija Bucić)

**Solution.** We denote a pawn that was initially at point  $A_i$  as  $i$ . We will prove part a) and then use it to show part b).

- We apply first operation  $i - 1$  times which will bring  $i$  and  $i + 1$  to points  $A_1$  and  $A_2$  and move every other pawn  $i - 1$  steps in clockwise direction.  
We can now apply second operation to swap  $i$  and  $i + 1$  as they are at points  $A_1$  and  $A_2$ . This does not affect the position of any other pawn.  
We now apply first operation  $n - i + 1$  times returning pawn  $k \neq i, i + 1$  to point  $A_k$  while moving pawn  $i$  to  $A_{i+1}$  and pawn  $i + 1$  to  $A_i$  which is exactly what we wanted.
- We present 2 possible solutions, one using induction and one not using induction.

**Solution 1:** By using the previous problem we can swap pawns  $(i, i + 1)$  as they are at points  $(A_i, A_{i+1})$  then  $(i, i + 2)$  as they are at points  $(A_{i+1}, A_{i+2})$  and carry on until we swap  $(i, j)$  as they were at points  $(A_{j-1}, A_j)$ . This brings us to the state where  $i$  is at  $A_j$  and each  $i + 1 \leq k \leq j$  is at point  $A_{k-1}$ .

We can now apply part a) to swap  $j$  with  $j - 1$  and similarly carry on till we swap  $j$  with  $i + 1$ . This will place  $j$  at  $A_i$  and move each  $i + 1 \leq k \leq j - 1$  to  $A_k$ .

This brings us to the state where we swapped pawns  $i$  and  $j$  leaving others where they were just as was desired.  $\square$

**Solution 2:** We use induction on  $n$  for the following claim:

We can swap any two pawns  $1 \leq i < j \leq k$ .

We note that the basis is exactly part *a*.

We assume we the claim holds for some  $k$ .

Hence we can swap any pawns  $1 \leq i < j \leq k$  and only need to show that we can swap  $i$  and  $k+1$  for any  $1 \leq i \leq k$ .

This follows as we can swap  $i$  and  $k$  then  $k$  and  $k+1$  by part a). then again  $k+1$  and  $i$  as they are now on points  $A_k$  and  $A_i$ .

□

**Problem 3.** Let  $ABC$  be a triangle. The external and internal angle bisectors of  $\angle CAB$  intersect side  $BC$  at  $D$  and  $E$ , respectively. Let  $F$  be a point on the segment  $BC$ . The circumcircle of triangle  $ADF$  intersects  $AB$  and  $AC$  at  $I$  and  $J$ , respectively. Let  $N$  be the mid-point of  $IJ$  and  $H$  the foot of  $E$  on  $DN$ . Prove that  $E$  is the incenter of triangle  $AHF$ .

(Steve Dinh)

**Solution.** Denote by  $\omega$  the circumcircle of  $\triangle AHF$ .

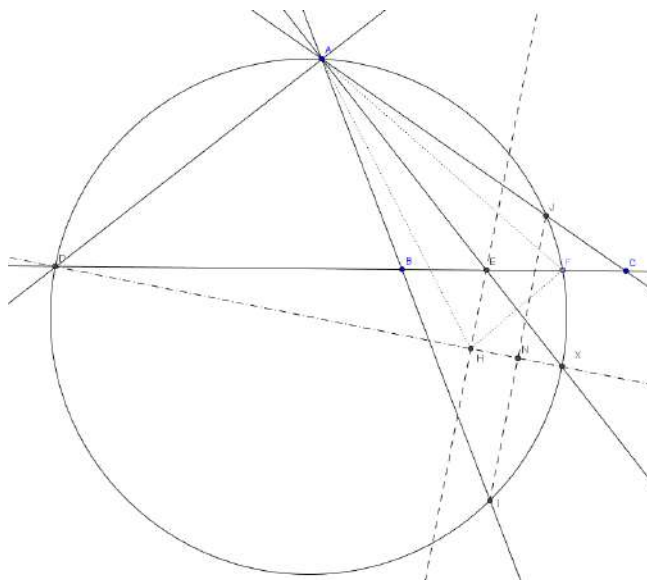

The key idea in the problem is to introduce a new point  $X$  which we define as the second intersection of  $DN$  and  $\omega$ .

We now note that the  $\angle JAD = \angle CAD = 90^\circ \pm \frac{\alpha}{2}$  and  $\angle IAD = \angle BAD = 90^\circ \pm \frac{\alpha}{2}$  where  $\alpha = \angle CAB$ . As  $AD$  is an external bisector of  $\angle CAB$ .

The  $\pm$  signs depend on the picture and student shouldn't be deducted any points for not noticing this.

Hence we have either  $\angle JAD = \angle BAD$  or  $\angle JAD + \angle IAD = 180^\circ$  so in both cases  $DI = DJ$ .

Now as  $N$  is midpoint of  $IJ$  this means that  $DN$  is bisector of  $IJ$  and hence passes through the centre of the. This shows that  $DX$  is a diameter of  $\omega$  and  $EH \parallel IJ$ .

We also notice that  $\angle EAD = 90^\circ$  as angle between bisectors and  $\angle XAD = 90^\circ$  as  $DX$  is a diameter. Hence  $X, A, E$  are collinear.

Now this gives us  $\angle DHE = \angle XHE = 90^\circ$  and  $\angle XFE = \angle DFE = 90^\circ$  as  $DX$  is a diameter of  $\omega$  and finally again  $\angle EAD = 90^\circ$ . All this gives us that quadrilaterals  $XFEH$  and  $ADEH$  are cyclic.

Final step is to use some angle chasing to get  $\angle AHE = \angle ADH = \angle AXF = \angle EXF = \angle EHF$  where first, second and fourth equalities are due to cyclicity of  $ADEH$ ,  $ADXF$  and  $XFEH$  respectively. Also  $\angle DFH = \angle EFH = \angle EXH = \angle AFD = \angle AFE$  where the second and fourth equalities are due to cyclicity of  $XFEH$  and  $ADXF$  respectively. This shows  $E$  is the incenter of  $\triangle AFH$  as desired.

**Problem 4.** Find all infinite sequences  $a_1, a_2, a_3, \dots$  of positive integers such that

- $a_{nm} = a_n a_m$ , for all positive integers  $n, m$ , and
- there are infinitely many positive integers  $n$  such that  $\{1, 2, \dots, n\} = \{a_1, a_2, \dots, a_n\}$ .

**Solution.** Instead of sequence  $a_n$ , we'll use notation with the function  $f(n)$  with same properties.

There exists only one such function:  $f(n) = n$ . We'll solve the problem with many separate facts.

**Fact 1:**  $f(1) = 1$ .

*Proof:* According to a) it holds  $f(1) = f(1)f(1) = f(1)^2$ . Since  $f(1)$  is positive integer, it can't be  $f(1) = 0$ , so it must be  $f(1) = 1$ .

**Fact 2:** Function  $f$  is bijective.

*Proof:* Firstly, we'll show that  $f$  is injective. Let  $a \neq b$  be two arbitrary positive integers and let's assume  $f(a) = f(b)$ . Since  $\{1, 2, \dots, n\} = \{f(1), f(2), \dots, f(n)\}$  holds for infinitely many positive integers  $n$ , it holds for some integer greater than  $a$  and  $b$ . Then, since  $f(a) = f(b)$ , set  $\{f(1), f(2), \dots, f(n)\}$  contains  $n-1$  or less (different) elements, but according to b), it contains  $n$  elements.

Secondly, we'll show that  $f$  is surjective. Let  $c$  be arbitrary integer and let's assume that  $f(n) \neq c$  for all positive integers  $n$ . Similarly as in first part of proof, let's take positive integer  $n$  such that  $\{1, 2, \dots, n\} = \{f(1), f(2), \dots, f(n)\}$  holds. Since  $c \in \{1, 2, \dots, n\}$ ,  $c$  is also element of the set  $\{f(1), f(2), \dots, f(n)\}$ , so there exists positive integer  $m \leq n$  such that  $f(m) = c$ .

**Fact 3:** Positive integer  $n$  is prime if and only if  $f(n)$  is prime.

*Proof:* Let's assume that  $n$  is prime, but  $f(n)$  isn't. Then it must be  $f(n) = a'b' = f(a)f(b) = f(ab)$ , where  $a', b'$  are positive integers greater than 1, and  $a, b$  are unique positive integers such that  $f(a) = a', f(b) = b'$  (they exist since  $f$  is bijective). Since  $f$  is injective,  $f(1) = 1$  and  $a', b'$  are not equal to 1, integers  $a, b$  are also not equal to 1. Since  $f$  is injective and  $f(n) = f(ab)$ , we have  $n = ab$ , so  $n$  is composite.

Let's assume that  $f(n)$  is prime, but  $n$  isn't. Then there exist positive integers  $a, b$  greater than one such that  $n = ab$ . From there we have  $f(n) = f(ab) = f(a)f(b)$ . Again from injectivity of  $f$  and  $f(1) = 1$ , we see that  $f(n)$  is product of two integers greater than 1.

**Fact 4:** If  $n = p_1^{a_1} p_2^{a_2} \dots p_k^{a_k}$  is unique factorization of positive integer  $n$ , then

$$f(n) = f(p_1)^{a_1} f(p_2)^{a_2} \dots f(p_k)^{a_k}$$

is unique factorization of positive integer  $f(n)$ .

*Proof:* From multiple use of the condition a) we get identity  $f(n) = f(p_1)^{a_1} f(p_2)^{a_2} \dots f(p_k)^{a_k}$ . From Fact 3, numbers  $f(p_i)$  are prime. Since  $f$  is injective, none of two numbers  $f(p_i)$  and  $f(p_j)$  are equal.

**Fact 5:** (Technical result) For all positive integers  $y < x$  there exist positive integer  $n_0$  such that for all positive integers  $n \geq n_0$  holds inequality

$$y^{n+1} < x^n.$$

*Proof:* It is sufficient to prove the fact only for consecutive integers  $y$  and  $y+1$  (because we'll have  $y^{n+1} < (y+1)^n \leq x^n$ ). By binomial theorem we have

$$(y+1)^n \geq y^n + ny^{n-1} = y^{n-1}(y+n).$$

Thus if we define  $n_0 = y^2 - y + 1$ , then for all  $n \geq n_0$  we have

$$(y+1)^n \geq y^{n-1}(y+n) \geq y^{n-1}(y+n_0) = y^{n-1}(y^2+1) > y^{n+1}.$$

*Another proof:* Inequality is equivalent to

$$\left(\frac{x}{y}\right)^n > y.$$

The fact follows from the fact that the expression on the left hand side is increasing and it is unbounded, while the right hand side is fixed.

**Fact 6:** For all prime numbers  $p$  we have  $f(p) \leq p$ .

*Proof:* Let  $p_1, p_2, \dots, p_n, \dots$  be the increasing sequence  $2, 3, 5, 7, \dots$  of all prime numbers. Let's take arbitrary prime number  $p_n$ . From the Fact 3 we have that  $f(p_n)$  is also a prime. Let's take positive integer  $n_0$  as the integer from the Fact 5, for positive integers  $y = p_n < p_{n+1} = x$ . Since b) holds for infinitely many positive integers, it holds for some positive integer  $N$  such that  $\{1, 2, \dots, N\} = \{f(1), f(2), \dots, f(N)\}$ , and such that  $N \geq p_n^{n_0}$ . Let  $\alpha$  be the greatest positive integer such that  $p_n^\alpha \leq N$ . From definitions of  $N$  and  $\alpha$  we have  $\alpha \geq n_0$ .

In set  $\{1, 2, \dots, N\}$  we'll observe all positive integers which are  $\alpha^{\text{th}}$  power of a prime number. Since  $N \geq p_n^\alpha$ , we have that  $p_n^\alpha$  is in that set. It is easy to see that all numbers  $p_1^\alpha, \dots, p_{n-1}^\alpha$  are also in that set. On the contrary, number  $p_{n+1}^\alpha$  is not in that set, because from the definition of  $\alpha$  and  $N$  respectively we have  $N < p_{n+1}^{\alpha+1} \leq p_{n+1}^\alpha$  (remember Fact 5 and  $\alpha \geq n_0$ ). Similarly, neither of the numbers  $p_m^\alpha$  (for  $m > n$ ) is not in the set  $\{1, 2, \dots, N\}$ .

Let us now observe all positive integers which are  $\alpha^{\text{th}}$  power of a prime and they are in the set  $\{f(1), f(2), \dots, f(N)\}$ . According to Fact 4, we have that  $f(n)$  is  $\alpha^{\text{th}}$  power of a prime if and only if  $n$  is  $\alpha^{\text{th}}$  power of a prime. From that and from previous paragraph we conclude that only such numbers are  $f(p_1^\alpha), \dots, f(p_n^\alpha)$ .

Now we have  $\{p_1^\alpha, \dots, p_n^\alpha\} = \{f(p_1^\alpha), \dots, f(p_n^\alpha)\}$ . Thus  $f(p_n^\alpha) \in \{p_1^\alpha, \dots, p_n^\alpha\}$ , so  $f(p_n^\alpha) = p_i^\alpha$  for some  $1 \leq i \leq n$ , which implies  $f(p_n)^\alpha = p_i^\alpha$ , for some  $1 \leq i \leq n \implies f(p_n) = p_i \leq p_n$ , which completes the proof.

**Fact 7:** For every positive integer we have  $f(n) = n$ .

*Proof:* From Fact 3 we have that  $f(p)$  if and only if  $p$  is prime. Let  $p_1, p_2, \dots, p_n, \dots$  be the increasing sequence  $2, 3, 5, 7, \dots$  of all prime numbers. From Fact 6 we have  $f(p_1) \leq p_1 \implies f(2) = 2$ . For  $n \geq 2$ , inductively and from injectivity of  $f$  we have  $f(p_n) > p_{n-1}$  and from Fact 6 we have  $f(p_n) \leq p_n$ , thus it must be  $f(p_n) = p_n$ , for all positive integers  $n$ . Now for arbitrary positive integer  $n$  from Fact 4 we have

$$f(n) = f(p_1)^{a_1} f(p_2)^{a_2} \dots f(p_k)^{a_k} = p_1^{a_1} p_2^{a_2} \dots p_k^{a_k} = n,$$

which completes our proof.

**Remark:** We can prove Fact 6 differently (without using Fact 5). We observe numbers  $1 \cdot 2 \cdot \dots \cdot n$  and  $f(1) \cdot f(2) \cdot \dots \cdot f(n)$ , and their unique factorizations. They coincide for infinitely many positive integers  $n$ . For fixed primes  $p, q$ , if we take sufficiently great  $n$ , we can use well-known formula for  $\nu_p(n!)$  to prove that  $\nu_p(n!) > \nu_q(n!)$  for all  $q > p$  (here positive integer  $n$  depends on  $p, q$ ).

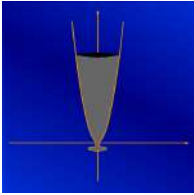

**3<sup>RD</sup> EUROPEAN MATHEMATICAL CUP**  
*6<sup>th</sup> December 2014–14<sup>th</sup> December 2014*  
Senior Category



**Problem 1.** Prove that there are infinitely many positive integers which can't be expressed as  $a^{d(a)} + b^{d(b)}$  where  $a$  and  $b$  are positive integers.

For positive integer  $a$  expression  $d(a)$  denotes the number of positive divisors of  $a$ . (Borna Vukorepa)

**Problem 2.** Jeck and Lisa are playing a game on an  $m \times n$  board, with  $m, n > 2$ . Lisa starts by putting a knight onto the board. Then in turn Jeck and Lisa put a new piece onto the board according to the following rules:

1. Jeck puts a queen on an empty square that is two squares horizontally and one square vertically, or alternatively one square horizontally and two squares vertically, away from Lisa's last knight.
2. Lisa puts a knight on an empty square that is on the same, row, column or diagonal as Jeck's last queen.

The one who is unable to put a piece on the board loses the game. For which pairs  $(m, n)$  does Lisa have a winning strategy?

(Stijn Cambie)

**Problem 3.** Let  $ABCD$  be a cyclic quadrilateral with the intersection of internal angle bisectors of  $\angle ABC$  and  $\angle ADC$  lying on the diagonal  $AC$ . Let  $M$  be the midpoint of  $AC$ . The line parallel to  $BC$  that passes through  $D$  intersects the line  $BM$  in  $E$  and the circumcircle of  $ABCD$  at  $F$  where  $F \neq D$ . Prove that  $BCEF$  is a parallelogram.

(Steve Dinh)

**Problem 4.** Find all functions  $f : \mathbb{R} \rightarrow \mathbb{R}$  such that for all  $x, y \in \mathbb{R}$  the following holds:

$$f(x^2) + f(2y^2) = (f(x + y) + f(y))(f(x - y) + f(y)).$$

(Matija Bucić)

*Time allowed: 240 minutes.*

*Each problem is worth 10 points.*

*Calculators are not allowed.*

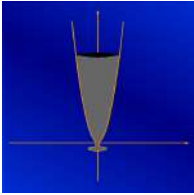

**3<sup>RD</sup> EUROPEAN MATHEMATICAL CUP**  
 6<sup>th</sup> December 2014–14<sup>th</sup> December 2014  
 Senior Category



## Problems and Solutions

**Problem 1.** Prove that there are infinitely many positive integers which can't be expressed as  $a^{d(a)} + b^{d(b)}$  where  $a$  and  $b$  are positive integers.

For positive integer  $a$  expression  $d(a)$  denotes the number of positive divisors of  $a$ . (Borna Vukorepa)

**Solution.** We will show that  $a^{d(a)}$  is a square of an integer for every positive integer  $a$ .

If  $a$  is a square of an integer, **any its power is also a square of an integer.**

If  $a$  is not a perfect square, number of it's positive divisors is even. We can prove this by pairing divisors of  $a$  as  $d$  and  $\frac{a}{d}$ . A divisor  $d$  won't be paired with itself because that would imply  $a = d^2$ . This proves that  $d(a)$  is even and hence  $a^{d(a)}$  is a perfect square for every positive integer  $a$ .

The expression in the problem is hence a sum of two squares. Every number of the form  $4t + 3$  can't be written as a sum of two squares because 0 and 1 are the only quadratic residues modulo 4, so it is impossible for a sum of two squares to give remainder 3 modulo 4.

**Problem 2.** Jeck and Lisa are playing a game on an  $m \times n$  board, with  $m, n > 2$ . Lisa starts by putting a knight onto the board. Then in turn Jeck and Lisa put a new piece onto the board according to the following rules:

1. Jeck puts a queen on an empty square that is two squares horizontally and one square vertically, or alternatively one square horizontally and two squares vertically, away from Lisa's last knight.
2. Lisa puts a knight on an empty square that is on the same, row, column or diagonal as Jeck's last queen.

The one who is unable to put a piece on the board loses the game. For which pairs  $(m, n)$  does Lisa have a winning strategy?

(Stijn Cambie)

**Solution.** We shall show that Lisa has a winning strategy if and only if  $m$  and  $n$  are both odd.

*Lisa's winning strategy*

Suppose the game is played on an  $m \times n$  board with  $m$  and  $n$  both odd. Then Lisa puts her first knight in a corner and partitions the remaining squares of the board into 'dominoes'. In each turn Jeck has to put a queen in one of these dominoes and Lisa puts a knight on the other square of the domino. As the board is finite, Jeck can't keep finding new dominoes and so Lisa will win.

*Jeck's winning strategy*

Suppose the game is played on an  $m \times n$  board with  $m$  or  $n$  even. We shall show that Jeck is able to partition the board into pairs of squares that are two squares horizontally and one square vertically, or alternatively one square horizontally and two squares vertically, away from each other. In each turn Lisa has to put a knight in one of these and Jeck puts a queen on the other square of the pair. As the board is finite, Lisa can't keep finding new pairs and so Jeck will win. Now we prove that Jeck can make the required partition.

*Case 1.* Suppose  $4|m$  or  $4|n$ . We know that any  $k \times 4l$  board ( $k \geq 2$ ) can be divided into  $2 \times 4$  and  $3 \times 4$  boards (firstly divide  $k \times 4l$  board in  $l$  boards of dimensions  $k \times 4$ ; after that every  $k \times 4$  board divide in  $\frac{k}{2}$  boards of dimensions  $2 \times 4$ , or in  $\frac{k-3}{2}$  boards of dimensions  $2 \times 4$  and one  $3 \times 4$  board, dependently on parity of  $k$ ). The following diagrams show that every  $2 \times 4$  and every  $3 \times 4$  board allows a required partition.

1	2	3	4
3	4	1	2

1	2	3	4
3	5	1	6
2	6	4	5

1 point.

Case 2. Suppose  $m, n \equiv 1, 2 \pmod{4}$ . Any  $(5 + 4k) \times (6 + 4l)$  board can be divided into a  $5 \times 6$  board, a  $4k \times 6$  board, a  $5 \times 4l$  board and a  $4k \times 4l$  board. The following diagram shows that a  $5 \times 6$  board allows a required partition.

1	2	14	13	12	11
3	4	12	11	14	15
2	1	13	15	7	8
4	3	5	6	9	10
5	6	9	10	8	7

According to case 1 a  $4k \times 6$  board, a  $5 \times 4l$  board and a  $4k \times 4l$  board also allow a partition.

Case 3. Suppose  $m, n \equiv 2, 3 \pmod{4}$ . Any  $(3 + 4k) \times (6 + 4l)$  board can be divided into a  $3 \times 6$  board, a  $4k \times 6$  board, a  $3 \times 4l$  board and a  $4k \times 4l$  board. The following diagram shows that a  $3 \times 6$  board allows a required partition.

1	2	3	4	7	8
3	4	1	6	9	5
2	6	9	5	8	7

According to case 1 a  $4k \times 6$  board, a  $3 \times 4l$  board and a  $4k \times 4l$  board also allow a partition.

Case 4. Suppose  $m, n \equiv 2 \pmod{4}$ . Any  $(6 + 4k) \times (6 + 4l)$  board can be divided into a  $6 \times 6$  board, a  $4k \times 6$  board, a  $6 \times 4l$  board and a  $4k \times 4l$  board. The  $6 \times 6$  board can be partitioned in two  $3 \times 6$  boards, which were already solved. According to case 1 a  $4k \times 6$  board, a  $6 \times 4l$  board and a  $4k \times 4l$  board also allow a partition.

**Problem 3.** Let  $ABCD$  be a cyclic quadrilateral with the intersection of internal angle bisectors of  $\angle ABC$  and  $\angle ADC$  lying on the diagonal  $AC$ . Let  $M$  be the midpoint of  $AC$ . The line parallel to  $BC$  that passes through  $D$  intersects the line  $BM$  in  $E$  and the circumcircle of  $ABCD$  at  $F$  where  $F \neq D$ . Prove that  $BCEF$  is a parallelogram.

(Steve Dinh)

**Solution.** We prove the problem in reverse as this is much more natural in this problem.

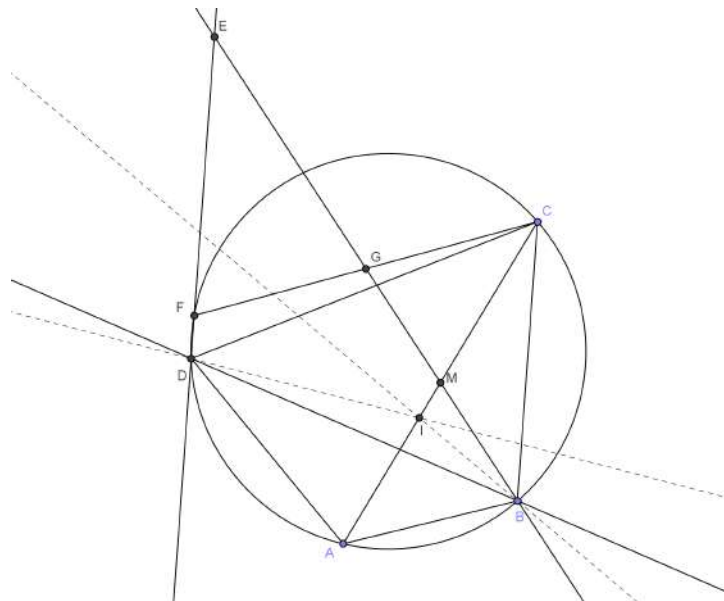

We note that if  $BCEF$  is a parallelogram then its diagonals are bisecting each other so the point  $G \equiv BE \cap CF$  should be the midpoint of  $CF$ .

If  $G$  is the midpoint of  $CF$  then  $\triangle GBC$  and  $\triangle GEF$  are congruent as  $CG = GF$  and  $FE \parallel BC$  gives  $\angle GEF = \angle GBC$  and  $\angle GFE = \angle GCB$ . Hence this implies  $BG = GE$  and in particular  $BCEF$  is a parallelogram as its diagonals bisect each other. Hence  $G$  being midpoint of  $CF$  is equivalent to our problem.

As  $M$  is the midpoint of  $AC$  by the midline theorem applied to triangle  $ACF$  we have  $G$  is the midpoint of  $CG$  if and only if  $MG \parallel AF$ . Hence we only need to prove  $BM \parallel AF$ .

Now we further notice that, using  $FD \parallel BC$ , this is equivalent to  $\angle AFD = \angle MBC$ .

We further see that  $\angle AFD = \angle ABD$  as they are angles over the same chord. So our claim is equivalent to  $\angle ABD = \angle MBC$ .

We add that here depending on the relative position of  $F$  on the circles we might have  $\pi - \angle AFD = \angle MBC$  but then  $\pi - \angle AFD = \angle ABD$  so the final conclusion still holds.

We know that  $\angle BDA = \angle BCM$  as they are angles over the same chord. Now this gives us that our claim is equivalent to the claim  $\triangle BCM \sim \triangle BDA$ .

The same angle equality shows that this is equivalent to  $\frac{BC}{CM} = \frac{AD}{BD}$ . Using the fact  $M$  is the midpoint of  $AC$  we have  $CM = \frac{AC}{2}$  so our claim is equivalent to  $2AD \cdot BC = BD \cdot AC$ .

We further have by the angle bisector theorem applied to  $\triangle ABC$  and  $\triangle CDA$ :

$$\frac{AB}{BC} = \frac{AI}{CI} = \frac{AD}{CD}$$

So using this our claim is equivalent to  $AB \cdot CD + AD \cdot BC = BD \cdot AC$  which we can recognise to be the Ptolomeys theorem for cyclic quadrilaterals.

**Problem 4.** Find all functions  $f : \mathbb{R} \rightarrow \mathbb{R}$  such that for all  $x, y \in \mathbb{R}$  the following holds:

$$f(x^2) + f(2y^2) = (f(x+y) + f(y))(f(x-y) + f(y)).$$

(Matija Bucić)

**Solution.** Let  $P(x, y)$  be the assertion  $f(x^2) + f(2y^2) = (f(x+y) + f(y))(f(x-y) + f(y))$ .

$P(0, x)$  gives us

$$f(0) + f(2x^2) = 2f(x)(f(x) + f(-x)) \quad (1)$$

and  $P(0, -x)$  gives us

$$f(0) + f(2x^2) = 2f(-x)(f(x) + f(-x)). \quad (2)$$

By combining (1) and (2) we get

$$f(x)^2 = f(-x)^2. \quad (3)$$

$P(0, 0)$  gives us  $2f(0) = 4f(0)^2$ , thus we have two cases:

1.  $f(0) = \frac{1}{2}$ .

$P(x, 0)$  gives us

$$f(x^2) = \left(f(x) + \frac{1}{2}\right)^2 - \frac{1}{2}, \quad (4)$$

while  $P(-x, 0)$  gives us

$$f(x^2) = \left(f(-x) + \frac{1}{2}\right)^2 - \frac{1}{2}. \quad (5)$$

Combining (4) and (5) and using (3) we get

$$f(x) = f(-x). \quad (6)$$

The assertion  $P(x^2, x^2)$  can be written as

$$f(x^4) + f(2x^4) = (f(2x^2) + f(x^2)) \left(\frac{1}{2} + f(x^2)\right). \quad (7)$$

For an arbitrary  $x \in \mathbb{R}$ , let us denote  $a = f(x)$ . Using (4) we get:

$$\begin{aligned} f(x^2) &= \left(a + \frac{1}{2}\right)^2 - \frac{1}{2}, \\ f(x^4) &= \left(f(x^2) + \frac{1}{2}\right)^2 - \frac{1}{2} = \left(a + \frac{1}{2}\right)^4 - \frac{1}{2}. \end{aligned}$$

Using (1) and (6) we get:

$$\begin{aligned} f(2x^2) &= 4f(x)^2 - \frac{1}{2} = 4a^2 - \frac{1}{2}, \\ f(2x^4) &= 4f(x^2)^2 - \frac{1}{2} = 4 \left( \left(a + \frac{1}{2}\right)^2 - \frac{1}{2} \right)^2 - \frac{1}{2}. \end{aligned}$$

Plugging the last 4 equations in (7) we get:

$$\left(a + \frac{1}{2}\right)^4 + 4 \left( \left(a + \frac{1}{2}\right)^2 - \frac{1}{2} \right)^2 - 1 = \left(4a^2 - 1 + \left(a + \frac{1}{2}\right)^2\right) \left(a + \frac{1}{2}\right)^2,$$

which is equivalent to

$$\left(a + \frac{1}{2}\right)^2 (4a - 2) = 0.$$

Therefore  $a = \pm \frac{1}{2}$  and  $f(x) = \pm \frac{1}{2}$ . Now if we use (6) in (1) we get

$$f(0) + f(2x^2) = 4(f(x))^2 = 1$$

so  $f(2x^2) = \frac{1}{2}$  for every  $x$ , now using (6) we conclude  $f(x) = \frac{1}{2}$  for all  $x$  which is easily checked to be a solution.

2.  $f(0) = 0$ .

We immediately see using  $P(x, 0)$  that

$$f(x^2) = f(x)^2. \quad (8)$$

By comparing  $P(x, y)$  and  $P(x, -y)$  and using (3) we get:

$$(f(y) - f(-y))(f(x+y) + f(x-y)) = 0.$$

If there exists  $c \in \mathbb{R}$  such that  $f(c) \neq f(-c)$  we have for all  $x$

$$f(x+c) = -f(x-c),$$

Plugging in  $x+c$  in  $x$  here gives us:

$$f(x+2c) = -f(x). \quad (9)$$

Specially,  $f(2c) = 0$ . Now,  $P(2c-y, y)$ :

$$\begin{aligned} f((2c-y)^2) + f(2y^2) &= (f(2c) + f(y))(f(2c-2y) + f(y)), \\ (-f(-y))^2 + f(2y^2) &= f(y)f(2c-2y) + f(y)^2, \\ f(2y^2) &= f(y)f(2c-2y) = -f(y)f(-2y) \end{aligned} \quad (10)$$

Let  $S(x)$  denote the statement  $(x \neq 0) \wedge (f(x) = f(-x) \neq 0)$ . If there is no  $d \in \mathbb{R}$  such that  $S(d)$  then  $f(x) = -f(-x)$  for all  $x \in \mathbb{R}$ .  $P(0, x)$  gives us

$$f(2x^2) = 2f(x)(f(x) + f(-x)) = 0,$$

which gives us another solution  $f(x) = 0$ . Now, let us assume that there exists  $d \in \mathbb{R}$  such that  $S(d)$  holds. Obviously,  $S(-d)$  holds, as well.  $P(0, d)$  gives us

$$f(2d^2) = 4f(d)^2$$

and (10) gives us

$$\begin{aligned} f(2d^2) &= -f(d)f(-2d) \\ f(-2d) &= -4f(d) \\ f(2d) &= -4f(-d) = -4f(d) = f(-2d) \end{aligned}$$

Therefore,  $S(2d)$  also holds. Inductively, we deduce that  $S(2^n d)$  holds for every  $n \in \mathbb{N}$ . Also,  $f(2^n d) = (-4)^n f(d)$ , which means that  $f$  is unbounded.

$P(x, c)$ , using the fact  $f(x^2) = f(x)^2$ :

$$f(x)^2 + f(2c^2) = f(x+c)f(x-c) + f(c)(f(x+c) + f(x-c)) + f(c)^2,$$

and since  $f(x+c) = -f(x-c)$  and  $f(2c^2) = 0$  (this follows from  $P(0, c)$ ) we have

$$f(x)^2 + f(x+c)^2 = f(c)^2,$$

which implies that  $f$  is bounded and that is contradiction. Therefore, there is no  $c \in \mathbb{R}$  such that  $f(c) = -f(c)$  and therefore

$$f(x) = f(-x), \quad \text{for all } x \in \mathbb{R}. \quad (11)$$

$P(0, x)$ :

$$f(2x^2) = 4f(x)^2 = 4f(x^2).$$

Therefore, using (11)

$$f(2x) = 4f(x), \quad \text{for all } x \in \mathbb{R}. \quad (12)$$

$P(x, y)$  can now be written as follows:

$$f(x)^2 + 3f(y)^2 = f(y)(f(x+y) + f(x-y)) + f(x+y)f(x-y),$$

and similarly,  $P(y, x)$  can be written as

$$f(y)^2 + 3f(x)^2 = f(x)(f(x+y) + f(x-y)) + f(x+y)f(x-y).$$

subtracting the previous two equalities

$$(f(x) - f(y))(2f(x) + 2f(y) - f(x+y) - f(x-y)) = 0. \quad (13)$$

Assume that for some  $x, y \in \mathbb{R}$   $f(x) = f(y) = a$ . Let  $f(x+y) = b$  and  $f(x-y) = c$ .

Now we have:

$$4a^2 = bc + ab + ac \quad (14)$$

$P(x + y, x - y)$ :

$$f(x + y)^2 + 4f(x - y)^2 = (f(2x) + f(x - y))(f(2y) + f(x - y)),$$

i.e.

$$b^2 + 4c^2 = (4a + c)^2 \quad (15)$$

If we plug in  $x \rightarrow x + y$ ,  $y \rightarrow x - y$  in (13) we get

$$(f(x + y) - f(x - y))(2f(x + y) + 2f(x - y) - f(2x) - f(2y)) = 0$$

i.e.

$$(b - c)(2b + 2c - 8a) = 0.$$

If  $b = c$  (15) gives us

$$\begin{aligned} 5b^2 &= (4a + b)^2, \\ b^2 &= 4a^2 + 2ab \end{aligned}$$

while (14) gives us

$$4a^2 = b^2 + 2ab$$

Thus,  $ab = 0$  and  $a = b = c = 0$  which implies  $2a + 2a - b - c = 0$ . On the other hand, if  $b \neq c$  we also have  $2a + 2a - b - c = 0$

Therefore,  $f(x) = f(y)$  implies  $2f(x) + 2f(y) = f(x + y) + f(x - y)$  while  $f(x) \neq f(y)$ , using (13) also implies  $2f(x) + 2f(y) = f(x + y) + f(x - y)$ .

Therefore, for all  $x, y$ :

$$2f(x) + 2f(y) = f(x + y) + f(x - y) \quad (16)$$

Now we have:

$$\begin{aligned} f(x)^2 + 3f(y)^2 &= f(x + y)f(x - y) + f(y)(f(x + y) + f(x - y)) \\ &= f(x + y)f(x - y) + f(y)(2f(x) + 2f(y)), \\ (f(x) - f(y))^2 &= f(x + y)f(x - y). \end{aligned} \quad (17)$$

Combining (16) i (17) gives us

$$(f(x + y) - f(x) - f(y))^2 = 4f(x)f(y). \quad (18)$$

Let  $g : \mathbb{R} \rightarrow \mathbb{R}_0^+$  be the function such that  $f(x) = g(x)^2$ . Equations (8), (11) and (12) imply that  $g(x^2) = g(x)^2$ ,  $g(-x) = g(x)$  and  $g(2x) = 2g(x)$ , respectively.

Equation (16) can be written as

$$f(x + y) - f(x) - f(y) = -(f(x - y) - f(x) - f(y)).$$

If  $f(x + y) - f(x) - f(y) \geq 0$ , from (18) we conclude that  $g(x + y) = g(x) + g(y)$ . Otherwise,  $f(x - y) - f(x) - f(y) \geq 0$  and equation (18) can be rewritten as

$$(f(x - y) - f(x) - f(y))^2 = 4f(x)f(y).$$

From the last equation we can conclude that  $g(x - y) = g(x) + g(y)$ .

Therefore

$$g(x + y) = g(x) + g(y) \quad \text{or} \quad g(x - y) = g(x) + g(y) \quad (19)$$

and thus one of the following two equations hold:

$$g(x^2 + y^2) + 2g(xy) = g(x^2 + y^2 + 2xy) = g(x + y)^2 \quad (20)$$

or

$$g(x^2 + y^2) + 2g(xy) = g(x^2 + y^2 - 2xy) = g(x - y)^2 \quad (21)$$

From (18) we conclude:

$$g(x + y) = g(x) + g(y) \quad \text{or} \quad g(x + y) = |g(x) - g(y)|. \quad (22)$$

By putting  $-y$  instead of  $y$  in (22) and using  $g(-y) = g(y)$  we get:

$$g(x - y) = g(x) + g(y) \quad \text{or} \quad g(x - y) = |g(x) - g(y)|. \quad (23)$$

Equations (22) and (23) imply that each of  $g(x - y)^2$  and  $g(x + y)^2$  can be written as either  $(g(x) + g(y))^2$  or  $(g(x) - g(y))^2$ . Thus, no matter whether (20) or (21) holds, one of the following equations must hold:

$$g(x^2 + y^2) + 2g(xy) = (g(x) + g(y))^2 \quad (24)$$

or

$$g(x^2 + y^2) + 2g(xy) = (g(x) - g(y))^2 \quad (25)$$

Without loss of generality we may assume that  $g(x) \geq g(y)$ . If  $g(x^2 + y^2) = g(x)^2 + g(y)^2$  then equations (24) i (25) imply that  $g(xy) = g(x)g(y)$  or  $g(xy) = -g(x)g(y)$  and because  $g$  is non-negative we conclude that  $g(xy) = g(x)g(y)$ . Otherwise,  $g(x^2 + y^2) = |g(x^2) - g(y^2)| = g(x)^2 - g(y)^2$  and we have

$$g(x)^2 + g(y)^2 \pm 2g(x)g(y) = g(x)^2 - g(y)^2 + 2g(xy)$$

and

$$g(y)^2 \pm g(x)g(y) = g(xy).$$

However, since  $g(x) \geq g(y)$  and  $g(xy) \geq 0$  we get

$$g(y)^2 + g(x)g(y) = g(xy).$$

Therefore, we conclude that

$$g(xy) = g(y)^2 + g(x)g(y) \quad (\text{for } g(y) \leq g(x)) \quad \text{or} \quad g(xy) = g(x)g(y). \quad (26)$$

Thus,

$$g(xy) \geq g(x)g(y). \quad (27)$$

If for some  $a, b$  it holds that  $g(a^2 + b^2) \neq g(a)^2 + g(b)^2$  we may assume that  $g(a) > g(b)$  and we have  $g(a^2 + b^2) = g(a)^2 - g(b)^2$ , and

$$g(ab) = g(b)^2 + g(a)g(b).$$

Let us denote  $a' = 2a$  and  $b' = \frac{1}{2}b$ . We have  $g(a') = 2g(a)$  and  $g(b') = \frac{1}{2}g(b)$ . Therefore,  $g(a') > g(a) > g(b) > g(b')$ . Note that  $g(a'b') = g(ab)$  and  $g(a')g(b') = g(a)g(b)$ . From (26) we conclude that either  $g(a'b') = g(a')g(b')$  or  $g(a'b') = g(b')^2 + g(a')g(b')$ . Each of these two cases is only possible when  $g(b) = 0$ . However, this implies that  $g(a^2 + b^2) = g(a^2) - g(b^2) = g(a^2) + g(b^2)$  which is a contradiction.

Therefore, there are no  $a, b$  such that  $g(a^2 + b^2) \neq g(a)^2 + g(b)^2$  and for all  $x, y \geq 0$   $g(x + y) = g(x) + g(y)$  which, together with the fact that  $g$  is non-negative, means that  $g$  satisfies a Cauchy functional equation whose only solution is  $g(x) = g(1)x$ . Since  $g(1) = g(1)^2$  we get that  $g(1) = 1$  and  $f(x) = x^2$  for all  $x$ .

Therefore there are 3 solutions which are given by

- $f(x) = 0 \quad \forall x \in \mathbb{R}$ ,
- $f(x) = \frac{1}{2} \quad \forall x \in \mathbb{R}$  and
- $f(x) = x^2 \quad \forall x \in \mathbb{R}$ .

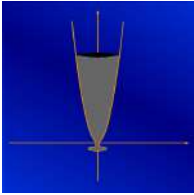

4<sup>TH</sup> EUROPEAN MATHEMATICAL CUP  
5<sup>th</sup> December 2015–13<sup>th</sup> December 2015  
Junior Category



**Problem 1.** We are given an  $n \times n$  board. Rows are labeled with numbers 1 to  $n$  downwards and columns are labeled with numbers 1 to  $n$  from left to right. On each field we write the number  $x^2 + y^2$  where  $(x, y)$  are its coordinates. We are given a figure and can initially place it on any field. In every step we can move the figure from one field to another if the other field has not already been visited and if at least one of the following conditions is satisfied:

- the numbers in those 2 fields give the same remainders when divided by  $n$ ,
- those fields are point reflected with respect to the center of the board.

Can all the fields be visited in case:

- $n = 4$ ,
- $n = 5$ ?

(Josip Pupić)

**Problem 2.** Let  $m, n, p$  be fixed positive real numbers which satisfy  $mnp = 8$ . Depending on these constants, find the minimum of

$$x^2 + y^2 + z^2 + mxy + nxz + pyz,$$

where  $x, y, z$  are arbitrary positive real numbers satisfying  $xyz = 8$ . When is the equality attained? Solve the problem for:

- $m = n = p = 2$ ,
- arbitrary (but fixed) positive real numbers  $m, n, p$ .

(Stijn Cambie)

**Problem 3.** Let  $d(n)$  denote the number of positive divisors of  $n$ . For positive integer  $n$  we define  $f(n)$  as

$$f(n) = d(k_1) + d(k_2) + \dots + d(k_m),$$

where  $1 = k_1 < k_2 < \dots < k_m = n$  are all divisors of the number  $n$ . We call an integer  $n > 1$  *almost perfect* if  $f(n) = n$ . Find all almost perfect numbers.

(Paulius Ašvydis)

**Problem 4.** Let  $ABC$  be an acute angled triangle. Let  $B', A'$  be points on the perpendicular bisectors of  $AC, BC$  respectively such that  $B'A \perp AB$  and  $A'B \perp AB$ . Let  $P$  be a point on the segment  $AB$  and  $O$  the circumcenter of the triangle  $ABC$ . Let  $D, E$  be points on  $BC, AC$  respectively such that  $DP \perp BO$  and  $EP \perp AO$ . Let  $O'$  be the circumcenter of the triangle  $CDE$ . Prove that  $B', A'$  and  $O'$  are collinear.

(Steve Dinh)

*Time allowed: 240 minutes.*

*Each problem is worth 10 points.*

*Calculators are not allowed.*

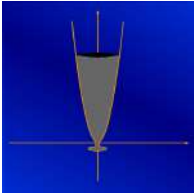

## Problems and Solutions

**Problem 1.** We are given an  $n \times n$  board. Rows are labeled with numbers 1 to  $n$  downwards and columns are labeled with numbers 1 to  $n$  from left to right. On each field of the board we write the number  $x^2 + y^2$  where  $(x, y)$  are its coordinates. We are given a figure and can initially place it on any field. In every step we can move the figure from one field to another if the other field has not already been visited and if at least one of the following conditions is satisfied:

- the numbers in those 2 fields give the same remainders when divided by  $n$ ,
- those fields are point reflected with respect to the center of the board.

Can all the fields be visited in case:

- $n = 4$ ,
- $n = 5$ ?

(Josip Pupić)

**Solution.** a) The answer is NO.

	1	2	3	4
1	2	5	10	17
2	5	8	13	20
3	10	13	18	25
4	17	20	25	36

	1	2	3	4
1	2	1	2	1
2	1	0	1	0
3	2	1	2	1
4	1	0	1	0

On the left we have the board from the problem, on the right we have the same board, but with remainders of the values from the board instead of the values themselves.

We will denote *field*  $i$  for a field with number  $i$  written on it in the right table. Let's assume that we can visit all of the fields. That means that at some point we will visit a *field* 1. Obviously, when using the first type of move, we can visit any other *field* 1 which hasn't yet been visited. Also, it is easy to notice, that for *field* 1, the reflection of that field is also a *field* 1. That means that both types of moves lead to another *field* 1. Also, in the same fashion we conclude that for the each step, if the figure is on the *field* 1, then in the step after (if that wasn't the last one) and in the step before (if that wasn't the first one) should be *field* 1.

Now we conclude that the first visited *field* 1 must be the field visited in the first step. Same way we conclude that the last visited *field* 1 must be the field visited in the last step. But, we know that all of *fields* 1 are visited consecutively, in exactly 8 moves (because there are 8 *fields* 1), while there are exactly 16 moves that we have to make. This leads to contradiction.

b) The answer is YES.

	1	2	3	4	5
1	2	5	10	17	26
2	5	8	13	20	29
3	10	13	18	25	34
4	17	20	25	36	41
5	26	29	34	41	50

	1	2	3	4	5
1	2	0	0	2	1
2	0	3	3	0	4
3	0	3	3	0	4
4	2	0	0	2	1
5	1	4	4	1	0

Again, on the left we have the board from the problem, on the right we have the same board, but with remainders of the values from the board instead of the values themselves.

We can move from any field to another with the same number written on the field in the right table by using the second move.

One idea to visit all the fields is the following:

- Find the 4 pairs of the fields of types *field i* and *field j*, such that all 8 fields are different, in each pair  $i \neq j$ , those two field in one pair are symmetric, and the second member of the  $n$ -th pair has the same value on the right board as the first member of the  $(n + 1)$ -th pair. Also, we want that all the values of the right table are mentioned through members of those pairs. For example:

$$((2, 2), (4, 4)), ((1, 4), (5, 2)), ((3, 5), (3, 1)), ((2, 1), (4, 5))$$

- Now, the algorithm is: after second member of  $n$ -th pair and before the first member of the  $(n + 1)$ -th pair visit all fields by using the first step. Of course, before first pair and after fourth pair move in similar way. Jump from the first member of the pair to the second member of the pair by using second step.

This is one of the ways to do it: We start with the field  $(3, 3)$ . Then we visit all of the *fields* 3, using the first move, in any way as long as the last visited field is  $(2, 2)$ . Then, using the second move, we visit the field  $(4, 4)$ . Again, using the first move we visit all *fields* 2 in any way as long as the last visited field is  $(1, 4)$ . Using the second move we visit the field  $(5, 2)$ . Then, using the first move we visit all *fields* 4 in any way as long as the last visited field is  $(3, 5)$ . In same fashion, using the second move we visit the field  $(3, 1)$ . After visiting all *fields* 0 in any way as long as the last visited field is  $(2, 1)$ , we visit the field  $(4, 5)$  using the second move. We conclude by visiting all *fields* 1 in any way.

**Problem 2.** Let  $m, n, p$  be fixed positive real numbers which satisfy  $mnp = 8$ . Depending on these constants, find the minimum of

$$x^2 + y^2 + z^2 + mxy + nxz + pyz,$$

where  $x, y, z$  are arbitrary positive real numbers satisfying  $xyz = 8$ . When is the equality attained? Solve the problem for:

- a)  $m = n = p = 2$ ,
- b) arbitrary (but fixed) positive real  $m, n, p$ .

(Stijn Cambie)

**First Solution.** a) Use AM-GM and  $xyz = 8$  to get

$$x^2 + y^2 + z^2 + xy + xy + yz + yz + xz + xz \geq 9\sqrt[9]{x^6y^6z^6} = 36.$$

We have equality for  $x = y = z = 2$ .

b) Using  $xyz = 8$ , we can transform the given expression:

$$x^2 + y^2 + z^2 + mxy + nxz + pyz = x^2 + \frac{8p}{x} + y^2 + \frac{8n}{y} + z^2 + \frac{8m}{z}$$

Since all numbers are positive reals, we can apply AM-GM inequality to get:

$$x^2 + \frac{8p}{x} = x^2 + \frac{4p}{x} + \frac{4p}{x} \geq 6\sqrt[3]{2p^2}$$

When we apply the same procedure for  $x, y, z$  and sum the inequalities, we get:

$$x^2 + y^2 + z^2 + mxy + nxz + pyz = x^2 + \frac{8p}{x} + y^2 + \frac{8n}{y} + z^2 + \frac{8m}{z} \geq 6\sqrt[3]{2}(\sqrt[3]{m^2} + \sqrt[3]{n^2} + \sqrt[3]{p^2}).$$

In order to get equality, we must have equality in all above inequalities and that happens for

$$\begin{aligned} x &= \sqrt[3]{4p}, \\ y &= \sqrt[3]{4n}, \\ z &= \sqrt[3]{4m}. \end{aligned}$$

Desired minimum is therefore

$$6\sqrt[3]{2}(\sqrt[3]{m^2} + \sqrt[3]{n^2} + \sqrt[3]{p^2}).$$

**Second Solution.** We only present solution for b) part here, marking scheme for a) part is the same as in first solution. We use weighted AM-GM:

$$\begin{aligned} & x^2 + y^2 + z^2 + mxy + nxz + pyz = \\ & \sqrt[3]{p^2} \frac{x^2}{\sqrt[3]{p^2}} + \sqrt[3]{n^2} \frac{y^2}{\sqrt[3]{n^2}} + \sqrt[3]{m^2} \frac{z^2}{\sqrt[3]{m^2}} + 2\sqrt[3]{m^2} \frac{mxy}{2\sqrt[3]{m^2}} + 2\sqrt[3]{n^2} \frac{nxz}{2\sqrt[3]{n^2}} + 2\sqrt[3]{p^2} \frac{pyz}{2\sqrt[3]{p^2}} \geq \\ & 3(\sqrt[3]{m^2} + \sqrt[3]{n^2} + \sqrt[3]{p^2}) \cdot \sqrt[3]{(\sqrt[3]{m^2} + \sqrt[3]{n^2} + \sqrt[3]{p^2})} \sqrt{\left(\frac{x^2}{\sqrt[3]{p^2}}\right)^{\sqrt[3]{p^2}} \left(\frac{y^2}{\sqrt[3]{n^2}}\right)^{\sqrt[3]{n^2}} \left(\frac{z^2}{\sqrt[3]{m^2}}\right)^{\sqrt[3]{m^2}}}. \\ & \sqrt[3]{(\sqrt[3]{m^2} + \sqrt[3]{n^2} + \sqrt[3]{p^2})} \sqrt{\left(\frac{\sqrt[3]{mxy}}{2}\right)^{2\sqrt[3]{m^2}} \left(\frac{\sqrt[3]{nxz}}{2}\right)^{2\sqrt[3]{n^2}} \left(\frac{\sqrt[3]{pyz}}{2}\right)^{2\sqrt[3]{p^2}}} \\ & = 3(\sqrt[3]{m^2} + \sqrt[3]{n^2} + \sqrt[3]{p^2}) \cdot \sqrt[3]{(\sqrt[3]{m^2} + \sqrt[3]{n^2} + \sqrt[3]{p^2})} \sqrt{\left(\frac{xyz}{2}\right)^{2(\sqrt[3]{m^2} + \sqrt[3]{n^2} + \sqrt[3]{p^2})}} \\ & = 3(\sqrt[3]{m^2} + \sqrt[3]{n^2} + \sqrt[3]{p^2}) \cdot \sqrt[3]{\left(\frac{xyz}{2}\right)^2} = 3(\sqrt[3]{m^2} + \sqrt[3]{n^2} + \sqrt[3]{p^2}) \cdot \sqrt[3]{4^2} = 6\sqrt[3]{2}(\sqrt[3]{m^2} + \sqrt[3]{n^2} + \sqrt[3]{p^2}) \end{aligned}$$

We have shown that the minimum value the expression can take is  $6\sqrt[3]{2}(\sqrt[3]{m^2} + \sqrt[3]{n^2} + \sqrt[3]{p^2})$ . Equality can only be achieved when  $x = \sqrt[3]{4p}, y = \sqrt[3]{4n}, z = \sqrt[3]{4m}$ .

**Problem 3.** Let  $d(n)$  denote the number of positive divisors of  $n$ . For positive integer  $n$  we define  $f(n)$  as

$$f(n) = d(k_1) + d(k_2) + \dots + d(k_m),$$

where  $1 = k_1 < k_2 < \dots < k_m = n$  are all divisors of the number  $n$ . We call an integer  $n > 1$  *almost perfect* if  $f(n) = n$ . Find all almost perfect numbers.

(Paulius Ašvydis)

**First Solution.** Alternative way to define  $f(n)$  is

$$f(n) = \sum_{k|n, k \geq 1} d(k).$$

Let  $n = p_1^{a_1} p_2^{a_2} \dots p_r^{a_r}$  be the prime factorisation of  $n$ . We have  $d(n) = \prod_{i=1}^r (a_i + 1)$ .

We prove the function  $f$  is multiplicative, in particular, given coprime  $n, m$  we have  $f(nm) = f(n)f(m)$ .

Using  $n, m$  are coprime for the second inequality and the fact that function  $d$  is multiplicative we get:

$$f(nm) = \sum_{k|nm} d(k) = \sum_{k_1|n, k_2|m} d(k_1 k_2) = \sum_{k_1|n, k_2|m} d(k_1) d(k_2) = \left( \sum_{k_1|n} d(k_1) \right) \left( \sum_{k_2|m} d(k_2) \right) = f(n)f(m)$$

If  $r = 1$  we have  $n = p_1^{a_1}$ . We note that divisors of  $n$  are  $1, p_1, p_1^2, \dots, p_1^{a_1}$  so  $f(n) = \sum_{i=0}^{a_1} (i+1) = \frac{(a_1+1)(a_1+2)}{2}$ .

Combining this with the multiplicativity result for  $f$  we deduce  $f(n) = \prod_{i=1}^r \frac{(a_i+1)(a_i+2)}{2}$ .

We now prove that for primes  $p \geq 5$  and  $p = 3$  provided  $a \geq 3$  we have  $f(p^a) = \frac{(a+1)(a+2)}{2} < \frac{2}{3}p^a$  by induction on  $a$ . As a basis  $3 < \frac{2p}{3}$  for  $p \geq 5$  and  $6 < \frac{2}{3} \cdot 3^3$ . For the step it is enough to notice that  $\frac{a+3}{a+1} \leq 2 < p$  in both cases.

Similarly we can prove for  $p = 2$  that  $f(p^a) < p^a$  provided  $a \geq 4$ . By explicitly checking the remaining cases  $p = 2$  and  $a = 1, 2, 3$  and  $p = 3$   $a = 1, 2$  we conclude  $f(p^a) \leq \frac{3}{2}p^a$  for all  $p, a$  and  $f(p^a) \leq p^a$  for all  $p \geq 3$  and  $p = 2, a \geq 4$ .

Assuming  $f(n) = n$  we would have  $\prod_{i=1}^k \frac{f(p_i^{a_i})}{p_i^{a_i}} = 1$  so the above considerations imply that only possible prime divisors are 2, 3. If  $k = 1$  the only possible solution is  $n = 3$ . If  $k = 2$  we have  $p_1 = 2, p_2 = 3$  and  $1 \leq a_1 \leq 2$  and  $1 \leq a_2 \leq 2$  which give 4 cases to check giving the other 2 solutions  $n = 18, 36$ .

So, all almost perfect numbers are 3, 18, 36.

**Second Solution.** We hereby present one similar but different solution which does not use a lot of properties of the function  $f$ .

Firstly, we will prove the following lemma:

**Lemma:** For any positive integer  $n > 1$  and prime  $p$  we have

$$f(pn) \leq 3f(n).$$

The equality holds if and only if  $GCD(p, n) = 1$ . *Proof:* For every integer  $m$  we have that the set of divisors of the number  $pm$  is the union of the following two sets:

- set of divisors of  $m$ ,
- set of divisors of  $m$  multiplied by  $p$ .

Also, those two mentioned sets are disjoint if and only if  $GCD(p, m) = 1$  (if we have that  $p, m$  are disjoint, then it is obvious that none of the divisors of  $pm$  are in both sets; if they are not coprime, then the number  $p$  belongs to both sets).

This is why we have  $d(pm) \leq 2d(m)$  and

$$f(pn) = \sum_{k|pn} d(k) \leq \sum_{k|n} d(k) + \sum_{k|n} d(pk) \leq f(n) + \sum_{k|n} 2d(k) = 3f(n).$$

In both inequalities equality holds if and only if sets from before are disjoint, i.e. when  $GCD(p, n) = 1$ .

Also, we simply see that  $f(2^k) = d(1) + d(2) + \dots + d(2^k) = 1 + 2 + \dots + (k+1) = \frac{(k+1)(k+2)}{2}$ .

Notice that if for some positive integer  $n$  we have  $f(n) < n$ , then for every  $p \geq 3$  we have  $f(pn) \leq 3f(n) \leq pf(n) < pn$ . Consequently, if  $f(n) < n$ , then for every odd  $m$  we have  $f(mn) < mn$ . Because of this, we will introduce new terms. Number  $n$  is *nice multiple* of  $m$  if  $m \mid n$  and  $\frac{m}{n}$  is odd number. Analogously, we define *nice divisor*. Our statement from above is: if for some  $n$  we have  $f(n) < n$ , then neither of its nice multiples is almost perfect number. Our strategy will be the following: check the cases of the "small" numbers and see ratio of numbers  $n$  and  $f(n)$ . When we have that  $n > f(n)$ , conclude that there are not almost perfect numbers among their nice multiples. With formula for  $f(2^k)$  conclude that for sufficiently big  $k$  (when  $f(2^k) < 2^k$ ) this is enough to conclude that there are no more almost perfect numbers. By induction, it is simple to prove that  $f(2^k) < 2^k$  for  $k \geq 4$ . Thus, there are no almost perfect numbers of the form  $2^k \cdot m$ , where  $k \geq 4$  and  $m$  is odd, since they all have  $2^k$  as their nice divisor. We only have to check the numbers of the form  $2^k \cdot m$ , where  $k \leq 3$  and  $m$  is odd.

*First case:  $k = 0$*

For any odd prime  $p$  we have  $f(p) = d(1) + d(p) = 3 \leq p$ . From that we see that  $n = 3$  is solution. Moreover, we do not have any more solutions: if some odd number has a prime divisor different from 3, since  $f(p) < p$  this number can not be almost perfect number; if it is a power of 3 bigger than 3, since  $f(9) < 3f(3) = 9$ , there are no more solutions as well (9 is nice divisor of every power of 3 bigger than 3).

*Second case:  $k = 1$*

For any odd prime we have  $f(2p) = 3f(2) = 9$ . If  $p > 5$  then we have  $2p > f(2p)$ , so for all almost perfect numbers of the form  $2^1 \cdot m$  number  $m$  has to have prime divisors 3 and/or 5.

We directly see that neither 6 or 10 is almost perfect. So, in this case, almost perfect number has to have a nice divisor of the form  $2 \cdot 9$ ,  $2 \cdot 15$  or  $2 \cdot 25$ . For  $n = 18$  we have another solution, in other two cases we have inequality  $f(n) < n$ . If we want to seek new solution in this case, since they cannot be nice multiples of 30 and 50, the only possibility is that almost perfect number has nice divisor  $2 \cdot 27$ . But we have (equality case in lemma) that  $f(2 \cdot 27) < 3f(2 \cdot 9) = 2 \cdot 27$ . So, there are no more solutions in this case.

*Third case:  $k = 2$*

For any odd prime we have  $f(4p) = 3f(4) = 18$ . If  $p > 5$  then we have  $4p > f(4p)$ , so for all almost perfect numbers of the form  $2^2 \cdot m$  number  $m$  has to have prime divisors 3 and/or 5.

We directly see that neither 12 or 20 is almost perfect. So, in this case, almost perfect number has to have a nice divisor of the form  $4 \cdot 9$ ,  $4 \cdot 15$  or  $4 \cdot 25$ . For  $n = 36$  we have another solution, in other two cases we have inequality  $f(n) < n$ . If we want to seek new solution in this case, since they cannot be nice multiples of 60 and 100, the only possibility is that almost perfect number has nice divisor  $4 \cdot 27$ . But we have (equality case in lemma) that  $f(4 \cdot 27) < 3f(4 \cdot 9) = 4 \cdot 27$ . So, there are no more solutions in this case.

*Fourth case:  $k = 3$*

For any odd prime we have  $f(8p) = 3f(8) = 30$ . Similarly to other cases, we only observe candidates of the form  $8 \cdot 3^l$ . Number  $8 \cdot 3$  is not almost perfect, all other candidates have nice divisor  $8 \cdot 9$ . But, we have  $f(72) = 60 < 72$ . As we always concluded, we do not have any new solutions.

So, all almost perfect numbers are 3, 18, 36.

**Problem 4.** Let  $ABC$  be an acute angled triangle. Let  $B', A'$  be points on the perpendicular bisectors of  $AC, BC$  respectively such that  $B'A \perp AB$  and  $A'B \perp AB$ . Let  $P$  be a point on the segment  $AB$  and  $O$  the circumcenter of the triangle  $ABC$ . Let  $D, E$  be points on  $BC, AC$  respectively such that  $DP \perp BO$  and  $EP \perp AO$ . Let  $O'$  be the circumcenter of the triangle  $CDE$ . Prove that  $B', A'$  and  $O'$  are collinear.

(Steve Dinh)

**Solution.** *Remark* We first start by giving some intuition on how the problem can be approached. We won't go into detail here but do give partial marks for correct ideas. We believe that any essentially correct solution should have them in the background so we don't require them to be written down explicitly.

We notice that if  $P \equiv A$  then  $O' \equiv B'$  while if  $P \equiv B$  we have  $O' \equiv A'$ . So the problem is equivalent to showing that as  $P$  varies on the segment  $AB$  respective  $O'$  map to a segment and we are now interested in identifying this segment.

It is hence natural to draw a picture not containing anything dependent on  $P$  and try to identify the line  $A'B'$ . Which turns out to be perpendicular to  $CM$  where  $M$  is the midpoint of  $AB$ .

Furthermore we note that  $B'M^2 - B'C^2 = AM^2 = A'M^2 - A'C^2$  and this defines the line uniquely (and shows  $A'B' \perp CM$ ).

The following sketch represents the problem setting when we do include the elements depending on  $P$ .

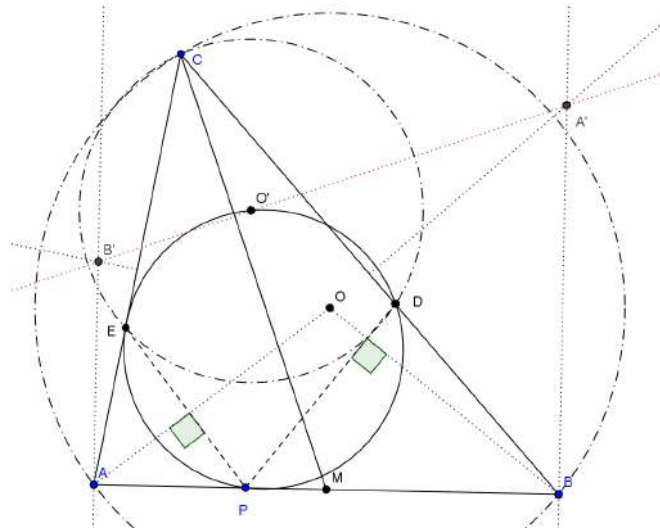

We now start with the formal proof.

It is enough to show that  $O'M^2 - O'C^2 = AM^2$  for all  $P$ , including  $P = A, B$ . Which allows us to draw the following sketch omitting  $B', C'$ .

We first prove that  $O'EPD$  is a cyclic quadrilateral. This follows as  $EO'D = 2ACB = APE + BPD = \pi - EPD$  as  $ACB = APE = BPD$ . This in turn implies  $PO'$  is an angle bisector of the angle  $EPD$  and  $PO' \perp AB$ .

We now have all the ingredients to show  $O'M^2 - O'C^2 = AM^2$ . The following sketch illustrates the last part of the proof.

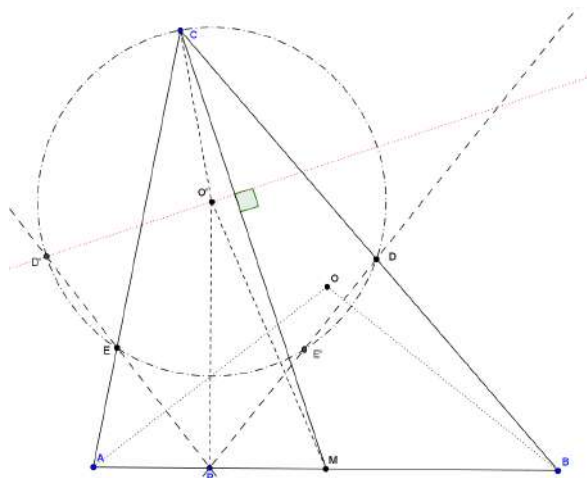

We introduce the point  $D'$  as the second intersection of the line  $PE$  and the circumcircle of  $CDE$  so that  $O'P^2 - O'C^2 = PE \cdot PD'$ .

Now as  $PO'$  is the angle bisector of  $EPD$  we have  $PD = PD'$  by the extended  $S - S - K$  congruency theorem and the following observation. There is some care needed here, mainly the options we get by  $S - S - K$  are  $PD = PD'$  or

$PD = PE$  but if  $PD = PE$  triangles  $P'EO'$  and  $P'DO'$  are congruent by  $S-S-S$  congruency theorem so in particular  $EO'P = DO'P = CAB$  while  $EPO' = DPO' = \frac{\pi}{2} - CAB$  so  $PD$  and  $PE$  are tangents so in fact  $D' \equiv E$  so the above claim is still true.

Now noticing triangles  $APE$  and  $BPD$  are similar we get  $\frac{PE}{AP} = \frac{PD}{BP}$  implying  $AP \cdot BP = PE \cdot PD = PE \cdot PD'$

As  $PO' \perp AB$  by using pythagoras theorem we get  $O'M^2 - O'C^2 - AM^2 = O'P^2 - O'C^2 + PM^2 - AM^2 = PD' \cdot PE - AP \cdot BP = 0$ . Where we used  $O'P^2 - O'C^2 = PE \cdot PD'$  by the power of the point  $P$  to the circumcircle of  $CDE$  and  $AM^2 - PM^2 = (BM + PM)(AM - PM) = AP \cdot PB$ .

This completes the proof. ■

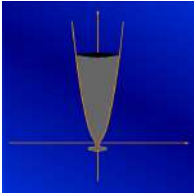

4<sup>TH</sup> EUROPEAN MATHEMATICAL CUP  
5<sup>th</sup> December 2015–13<sup>th</sup> December 2015  
Senior Category



**Problem 1.**  $A = \{a, b, c\}$  is a set containing three positive integers. Prove that we can find a set  $B \subset A$ ,  $B = \{x, y\}$  such that for all odd positive integers  $m, n$  we have

$$10 \mid x^m y^n - x^n y^m.$$

(Tomi Dimovski)

**Problem 2.** Let  $a, b, c$  be positive real numbers such that  $abc = 1$ . Prove that

$$\frac{a + b + c + 3}{4} \geq \frac{1}{a + b} + \frac{1}{b + c} + \frac{1}{c + a}.$$

(Dimitar Trenevski)

**Problem 3.** Circles  $k_1$  and  $k_2$  intersect in points  $A$  and  $B$ , such that  $k_1$  passes through the center  $O$  of the circle  $k_2$ . The line  $p$  intersects  $k_1$  in points  $K$  and  $O$  and  $k_2$  in points  $L$  and  $M$ , such that the point  $L$  is between  $K$  and  $O$ . The point  $P$  is orthogonal projection of the point  $L$  to the line  $AB$ . Prove that the line  $KP$  is parallel to the  $M$ -median of the triangle  $ABM$ .  
(Matko Ljulj)

**Problem 4.** A group of mathematicians is attending a conference. We say that a mathematician is  $k$ -content if he is in a room with at least  $k$  people he admires or if he is admired by at least  $k$  other people in the room. It is known that when all participants are in a same room then they are all at least  $3k + 1$ -content. Prove that you can assign everyone into one of 2 rooms in a way that everyone is at least  $k$ -content in his room and neither room is empty. *Admiration is not necessarily mutual and no one admires himself.*

(Matija Bucić)

*Time allowed: 240 minutes.*

*Each problem is worth 10 points.*

*Calculators are not allowed.*

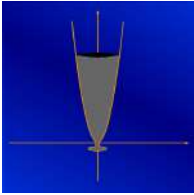

4<sup>TH</sup> EUROPEAN MATHEMATICAL CUP  
5<sup>th</sup> December 2015–13<sup>th</sup> December 2015  
Senior Category



## Problems and Solutions

**Problem 1.**  $A = \{a, b, c\}$  is a set containing three positive integers. Prove that we can find a set  $B \subset A$ ,  $B = \{x, y\}$  such that for all odd positive integers  $m, n$  we have

$$10 \mid x^m y^n - x^n y^m.$$

*(Tomi Dimovski)*

**Solution.** Let  $f(x, y) = x^m y^n - x^n y^m$ . If  $n = m$ , the problem statement will be fulfilled no matter how we choose  $B$  so from now on, without loss of generality, we consider  $n > m$ . Since  $m$  and  $n$  are both odd, we have that  $n - m$  is even and we get

$$f(x, y) = x^m y^m (y^{n-m} - x^{n-m})$$

$$\implies f(x, y) = x^m y^m (y^2 - x^2) Q(x, y)$$

$$\implies f(x, y) = x^m y^m (y - x)(y + x) Q(x, y),$$

where  $Q(x, y) = y^{n-m-2} + y^{n-m-4} x^2 + \dots + x^{n-m-2}$ .

Now if one of  $x, y$  is even,  $f(x, y)$  is even. If both are odd, then  $f(x, y)$  is again even since  $x + y$  and  $x - y$  are even in that case. This shows that we only need to consider divisibility by 5. If  $A$  contains at least one element divisible by 5, we can put it in  $B$  and that will give us the solution easily. Now we consider the case when none of the elements in  $A$  is divisible by 5. If some two numbers in  $A$  give the same remainder modulo 5, we can choose them and then  $x - y$  will be divisible by 5 which solves the problem. Now we consider the case when all remainders modulo 5 in  $A$  are different. Take a look at the pairs (1, 4) and (2, 3). Since we have three different remainders modulo 5 in  $A$ , by pigeonhole principle one of these pairs has to be completely in  $A$  (when elements are considered modulo 5). Then if we pick the numbers from  $A$  that correspond to those two remainders we get that  $x + y$  is divisible by 5 so the problem statement is fulfilled again. This completes the proof.

**Problem 2.** Let  $a, b, c$  be positive real numbers such that  $abc = 1$ . Prove that

$$\frac{a+b+c+3}{4} \geq \frac{1}{a+b} + \frac{1}{b+c} + \frac{1}{c+a}.$$

(Dimitar Trenevski)

**First Solution.** Rewrite the left hand side of inequality in following way:

$$\frac{a+b+c+3}{4} = \frac{a+b+c+3}{4\sqrt{abc}} = \frac{a+1}{4\sqrt{abc}} + \frac{b+1}{4\sqrt{abc}} + \frac{c+1}{4\sqrt{abc}}.$$

Rewrite denominators:

$$\frac{a+1}{4\sqrt{abc}} + \frac{b+1}{4\sqrt{abc}} + \frac{c+1}{4\sqrt{abc}} = \frac{a+1}{2\sqrt{ab \cdot c} + 2\sqrt{ac \cdot b}} + \frac{b+1}{2\sqrt{bc \cdot a} + 2\sqrt{ab \cdot c}} + \frac{c+1}{2\sqrt{ac \cdot b} + 2\sqrt{bc \cdot a}},$$

and then by arithmetic mean – geometric mean inequality, we have

$$= \frac{a+1}{2\sqrt{ab \cdot c} + 2\sqrt{ac \cdot b}} + \frac{b+1}{2\sqrt{bc \cdot a} + 2\sqrt{ab \cdot c}} + \frac{c+1}{2\sqrt{ac \cdot b} + 2\sqrt{bc \cdot a}} \geq \frac{a+1}{ab+c+ac+b} + \frac{b+1}{bc+a+ab+c} + \frac{c+1}{ac+b+bc+a}.$$

This problem is now solved, because

$$\begin{aligned} \frac{a+1}{ab+c+ac+b} + \frac{b+1}{bc+a+ab+c} + \frac{c+1}{ac+b+bc+a} &= \frac{a+1}{(a+1)(b+c)} + \frac{b+1}{(b+1)(a+c)} + \frac{c+1}{(c+1)(a+b)} = \\ &= \frac{1}{a+b} + \frac{1}{b+c} + \frac{1}{c+a} \end{aligned}$$

**Second Solution.** We introduce change of variables:  $a = x^3, b = y^3, c = z^3$ . We now have the condition  $xyz = 1$ .

We apply Schur inequality (with exponent  $r = 1$ ) to the numerator of the left hand side:

$$x^3 + y^3 + z^3 + 3xyz \geq x^2y + x^2z + y^2x + y^2z + z^2x + z^2y,$$

to obtain inequality

$$\frac{x^2y + x^2z + y^2x + y^2z + z^2x + z^2y}{4} \geq \frac{1}{x^3 + y^3} + \frac{1}{y^3 + z^3} + \frac{1}{z^3 + x^3}.$$

We apply arithmetic mean – geometric mean inequality for the denominators of the right hand side:

$$x^3 + y^3 \geq 2x^{3/2}y^{3/2} \implies \frac{1}{x^3 + y^3} \leq \frac{1}{2x^{3/2}y^{3/2}} = \frac{1}{2}z^2\sqrt{yz},$$

and similarly to the other terms. We now have to prove

$$\frac{x^2y + x^2z + y^2x + y^2z + z^2x + z^2y}{2} \geq x^2\sqrt{yz} + y^2\sqrt{xz} + z^2\sqrt{xy}.$$

We apply arithmetic mean – geometric mean inequality in pairs on the left hand side:

$$\frac{x^2y + x^2z}{2} \geq x^2\sqrt{yz},$$

$$\frac{y^2x + y^2z}{2} \geq y^2\sqrt{xz},$$

$$\frac{z^2x + z^2y}{2} \geq z^2\sqrt{xy}.$$

Summing up inequalities from above finishes the proof.

**Problem 3.** Circles  $k_1$  and  $k_2$  intersect in points  $A$  and  $B$ , such that  $k_1$  passes through the center  $O$  of the circle  $k_2$ . The line  $p$  intersects  $k_1$  in points  $K$  and  $O$  and  $k_2$  in points  $L$  and  $M$ , such that the point  $L$  is between  $K$  and  $O$ . The point  $P$  is orthogonal projection of the point  $L$  to the line  $AB$ . Prove that the line  $KP$  is parallel to the  $M$ -median of the triangle  $ABM$ .

(Matko Ljulj)

**Solution.** Let the point  $C$  be the midpoint of the line segment  $\overline{AB}$ . We have to prove  $MC \parallel KP$ .

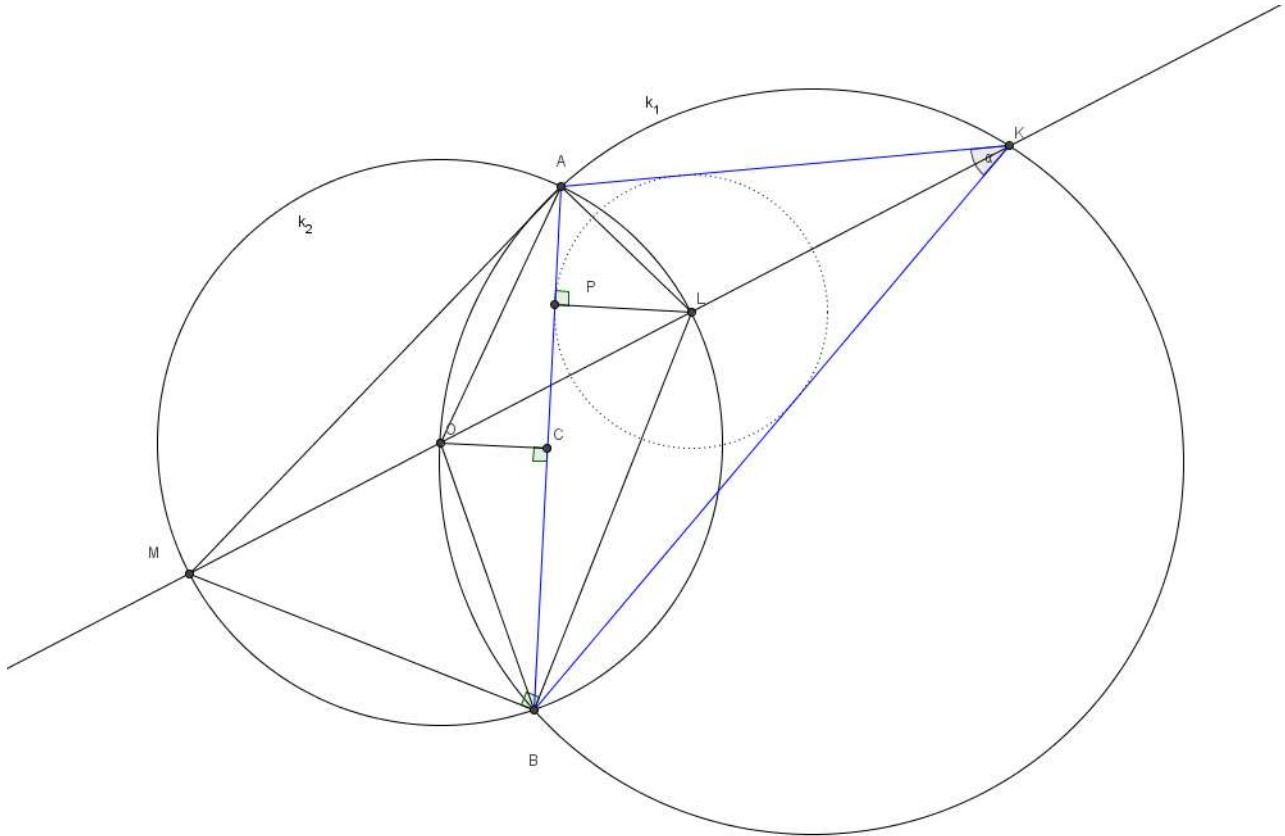

Let us introduce angle  $\alpha := \angle BKA$ . Notice that

$$\angle BLA = 180 - \angle BMA = 180 - \frac{1}{2}\angle BOA = 180 - \frac{1}{2}(180 - \angle BKA) = 90 + \frac{1}{2}\alpha.$$

Also, notice that the point  $O$  is midpoint of the arc  $\widehat{AB}$ . Thus the line  $KO$  is bisector of the angle  $\angle BKA$ . From the two claims above, we deduce that  $L$  is incenter of the triangle  $ABK$ . Moreover, notice that  $\overline{ML}$  is diameter of the circle  $k_2$ , thus  $\angle ABM = 90$ . Since  $BL$  is angle bisector of the angle  $\angle ABK$ , we deduce that  $BM$  is exterior angle bisector of the same angle. Thus, since  $M$  lies on angle bisector  $KM$  and exterior angle bisector  $BM$ ,  $M$  is the center of the excircle for the triangle  $ABK$ . Thus, we have to prove that the line passing through the incenter  $L$  of the triangle  $ABK$  and point of the tangency of incircle of the same triangle is parallel to the line passing through the center of the excircle  $M$  and the midpoint  $C$  of the line segment  $\overline{AB}$ . This is a well known lemma, which completes the proof.

**Problem 4.** A group of mathematicians is attending a conference. We say that a mathematician is  $k$ -content if he is in the room with at least  $k$  people he admires or if he is admired by at least  $k$  other people in the room. It is known that when all participants are in the same room then they are all at least  $3k + 1$ -content. Prove that you can assign everyone into one of the 2 rooms in a way that everyone is at least  $k$ -content in his room and neither room is empty. *Admiration is not necessarily mutual and no one admires himself.*

(Matija Bucić)

**Solution.** We will for simplicity and clarity of presentation use some basic graph theoretic terms, this is in no way essential.

We represent the situation by a directed graph (abbr. digraph)  $G(V, E)$  where each vertex  $v \in V(G)$  represents a mathematician and each edge  $e \in E(G)$  represents an admiration relation. Given  $v \in V(G)$  we define out-degree of  $v$  denoted  $o(v)$  as the number of edges starting in  $v$  (so the number of mathematicians  $v$  admires) and in-degree  $i(v)$  as the number of edges ending in  $v$  (so the number of mathematicians who admire  $v$ ). Given  $X \subseteq V$  by  $G(X)$  we denote the induced subgraph (a graph with vertex set  $X$  and edges inherited from  $G$ ). We say that a digraph is a  $k$ -digraph if for every  $v \in V(G)$  we have  $i(v) \geq k$  or  $o(v) \geq k$ .

So the question can be reformulated as: Given  $G$  is a  $3k + 1$ -digraph we can split its vertices into 2 vertex disjoint classes such that each induced subgraph on class is a  $k$  digraph.

We call a subset  $X$  of vertices of  $G$   $k$ -tight if for any  $Y \subseteq X$  we have a vertex  $v \in Y$  such that  $i_{G(Y)}(v) \leq k$  and  $o_{G(Y)}(v) \leq k$ . A partition of  $V$ ,  $(A_1, A_2)$  is feasible if  $A_1$  is  $k$ -tight and  $A_2$  is  $k$ -tight.

We first assume there are no feasible partitions.

In this case consider a minimal size subset  $A_1 \subseteq V(G)$  subject to  $G(A_1)$  being a  $k$ -digraph, we define  $A_2 \equiv V(G) - A_1$ . Given a subset  $X \subset A_1$ ,  $G(X)$  is not a  $k$ -digraph so there is a vertex  $v \in X$  such that  $o_{G(X)}(v) < k$  and  $i_{G(X)}(v) < k$  which shows that any proper subset of  $A_1$  satisfies the condition of  $k$ -tightness. For the case of  $X \equiv A_1$  by removing any vertex  $v \in A_1$  the graph  $G' \equiv G(A_1 - \{v\})$ , by minimality assumption on  $A_1$ , must contain a vertex  $w$  such that  $o_{G'}(w) < k$  and  $i_{G'}(w) < k$  so as there is only one extra vertex in  $G(A_1)$ , namely  $v$   $o_{G(A_1)}(w) \leq k$ ,  $i_{G(A_1)}(w) \leq k$ . In particular this shows  $A_1$  is  $k$ -tight.

This implies  $A_2$  is not  $k$ -tight by our assumption so there exists an  $A'_2 \subseteq A_2$  such that  $A'_2$  is a  $k + 1$  digraph. Now applying the following proposition to extend the pair  $(A_1, A'_2)$  to a full partition which satisfies the conditions of the problem.

Given disjoint subsets  $A, B \subseteq V(G)$  we say  $(A, B)$  is a solution pair if both  $G(A)$  and  $G(B)$  are  $k$ -digraphs.

**Proposition:** If a  $2k + 1$  digraph  $G$  admits a solution pair it admits a partition with both induced graphs of both classes being  $k$ -digraphs.

**Proof.** Take a maximal solution pair  $(A, B)$ , the condition in the lemma guaranteeing it exists. Let  $C = V(G) - (A \cup B)$ , if  $C$  is empty we are done so assume  $|C| > 0$ . By our assumption  $(A, B \cup C)$  is not a solution pair so there is some  $x \in C$  such that  $o_{G(B \cup C)}(x), i_{G(B \cup C)}(x) < k$  so as  $G$  is  $2k + 1$  digraph  $i_G(x) \geq 2k + 1$  or  $o_G(x) \geq 2k + 1$  so either  $o_{G(A \cup \{x\})}(x) > k + 1$  or  $i_{G(A \cup \{x\})}(x) > k + 1$  so in particular  $(A \cup \{x\}, B)$  is a solution pair contradicting maximality and completing our argument. ■

Hence we are left with the case in which we have at least one feasible partition. We pick the feasible partition  $(A, B)$  maximizing  $w(A, B) = |E(G(A))| + |E(G(B))|$ . The fact that  $A$  is  $k$ -tight implies there is an  $x$  with  $o_{G(A)}(x) \leq k$ ,  $i_{G(A)}(x) \leq k$  so  $x$  needs to have at least  $k + 1$  edges in or out of  $B$  so  $|B| \geq k + 1$  and by symmetry  $|A| \geq k + 1$ .

We now prove that there exist an  $X \subseteq A$  such that  $G(X)$  is a  $k$ -digraph, by contradiction. Assuming the opposite we notice that for any  $x \in B$ ,  $B - \{x\}$  is still  $k$ -tight while  $B$  being  $k$ -tight implies there is an  $x \in B$  such that  $o_{G(B)}(x) \leq k$ ,  $i_{G(B)}(x) \leq k$  so for this  $x$  we have  $A \cup \{x\}$  is also  $k$ -tight. Hence, for  $A' = A \cup \{x\}$  and  $B' = B - \{x\}$ ,  $(A', B')$  is a feasible partition. We considering the change in edges which moving  $x$  causes we have  $w(A', B') - w(A, B) \geq 3k + 1 - k - k - k = 1$  as we know  $i_G(x) \geq 3k + 1$  or  $o_G(x) \geq 3k + 1$  so moving  $x$  from  $B$  to  $A$  increases number of edges in  $A$  by at least  $3k + 1 - k$  while the choice of  $x$  in  $B$  means we lose at most  $k + k$  edges in  $B$ . This is a contradiction to maximality of  $(A, B)$ .

Analogously we can find  $Y \subseteq B$  with  $G(Y)$  a  $k$ -digraph. Now applying the above proposition yet again we are done. ■

*Remark:* The same argument with slightly modified weight function can be used to show the result for non symmetric rooms, in particular if the graph is a  $k + l + \max(k, l) + 1$  digraph it can be partitioned into  $k$ - digraph and  $l$  digraph parts.

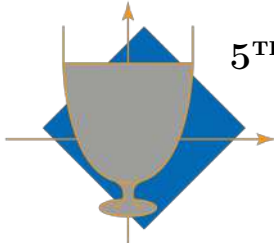

5<sup>TH</sup> EUROPEAN MATHEMATICAL CUP  
3<sup>rd</sup> December 2016–11<sup>th</sup> December 2016  
Junior Category



**Problem 1.** A grasshopper is jumping along the number line. Initially it is situated at zero. In  $k$ -th step, the length of his jump is  $k$ .

- If the jump length is even, then it jumps to the left, otherwise it jumps to the right (for example, firstly it jumps one step to the right, then two steps to the left, then three steps to the right, then four steps to the left...). Will it visit on every integer at least once?
- If the jump length is divisible by three, then it jumps to the left, otherwise it jumps to the right (for example, firstly it jumps one step to the right, then two steps to the right, then three steps to the left, then four steps to the right...). Will it visit every integer at least once?

(Matko Ljulj)

**Problem 2.** Two circles  $C_1$  and  $C_2$  intersect at points  $A$  and  $B$ . Let  $P, Q$  be points on circles  $C_1, C_2$  respectively, such that  $|AP| = |AQ|$ . The segment  $PQ$  intersects circles  $C_1$  and  $C_2$  in points  $M, N$  respectively. Let  $C$  be the center of the arc  $BP$  of  $C_1$  which does not contain point  $A$  and let  $D$  be the center of arc  $BQ$  of  $C_2$  which does not contain point  $A$ . Let  $E$  be the intersection of  $CM$  and  $DN$ . Prove that  $AE$  is perpendicular to  $CD$ .

(Steve Dinh)

**Problem 3.** Prove that for all positive integers  $n$  there exist  $n$  distinct, positive rational numbers with sum of their squares equal to  $n$ .

(Daniyar Aubekarov)

**Problem 4.** We will call a pair of positive integers  $(n, k)$  with  $k > 1$  a *lovely couple* if there exists a table  $n \times n$  consisting of ones and zeros with following properties:

- In every row there are exactly  $k$  ones.
- For each two rows there is exactly one column such that on both intersections of that column with the mentioned rows, number one is written.

Solve the following subproblems:

- Let  $d \neq 1$  be a divisor of  $n$ . Determine all remainders that  $d$  can give when divided by 6.
- Prove that there exist infinitely many lovely couples.

(Miroslav Marinov, Daniel Atanasov)

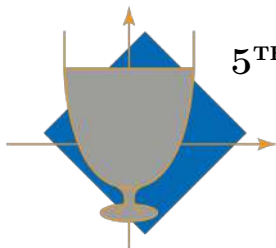

5<sup>TH</sup> EUROPEAN MATHEMATICAL CUP  
3<sup>rd</sup> December 2016–11<sup>th</sup> December 2016  
Junior Category



## Problems and Solutions

**Problem 1.** A grasshopper is jumping along the number line. Initially it is situated at zero. In  $k$ -th step, the length of his jump is  $k$ .

- a) If the jump length is even, then it jumps to the left, otherwise it jumps to the right (for example, firstly it jumps one step to the right, then two steps to the left, then three steps to the right, then four steps to the left...). Will it visit on every integer at least once?
- b) If the jump length is divisible by three, then it jumps to the left, otherwise it jumps to the right (for example, firstly it jumps one step to the right, then two steps to the right, then three steps to the left, then four steps to the right...). Will it visit every integer at least once?

(Matko Ljulj)

**Solution.** Let us denote with  $x_k$  position in the  $k$ -th step.

- a) For even  $n = 2k$  we have

$$\begin{aligned}x_{2k} &= 1 - 2 + 3 + \dots + (2k - 1) - 2k = \\(1 + 2 + 3 + \dots + 2k) - 2(2 + 4 + 6 + \dots + 2k) &= \\ \frac{3k(3k + 1)}{2} - 4 \frac{k(k + 1)}{2} &= -k.\end{aligned}$$

For odd  $n = 2k + 1$  we have

$$x_{2k+1} = x_{2k} + (2k + 1) = k + 1.$$

Hence we see that all integers occur exactly once in sequence  $(x_k)_k$ : positive integer  $n$  occur in  $(2n - 1)$ -th place, negative integer  $-n$  (for some  $n > 0$ ) occurs in  $(2n)$ -th place.

- b) For  $n = 3k$  we have

$$\begin{aligned}x_{3k} &= 1 + 2 - 3 + \dots + (3k - 2) + (3k - 1) - 3k = \\(1 + 2 + 3 + \dots + 3k) - 2(3 + 6 + 9 + \dots + 3k) &= \\ \frac{2k(2k + 1)}{2} - 6 \frac{k(k + 1)}{2} &= \frac{3k(k - 1)}{2}.\end{aligned}$$

For  $k = 0, 1$  we have that  $x_{3k} = 0$ . For all other  $k$  we have  $x_{3k} > 0$  since it is a product of positive numbers. For  $n = 3k + 1, n = 3k + 2$  we have

$$x_{3k+1} = x_{3k} + (3k + 1) > 0, x_{3k+2} = x_{3k} + (3k + 1) + (3k + 2) > 0.$$

Thus, all  $x_k$  are non-negative, and grasshopper will not reach any negative integer.

**Problem 2.** Two circles  $C_1$  and  $C_2$  intersect at points  $A$  and  $B$ . Let  $P, Q$  be points on circles  $C_1, C_2$  respectively, such that  $|AP| = |AQ|$ . The segment  $\overline{PQ}$  intersects circles  $C_1$  and  $C_2$  in points  $M, N$  respectively. Let  $C$  be the center of the arc  $BP$  of  $C_1$  which does not contain point  $A$  and let  $D$  be the center of arc  $BQ$  of  $C_2$  which does not contain point  $A$ . Let  $E$  be the intersection of  $CM$  and  $DN$ . Prove that  $AE$  is perpendicular to  $CD$ .

(Steve Dinh)

**First Solution.** We present the following sketch:

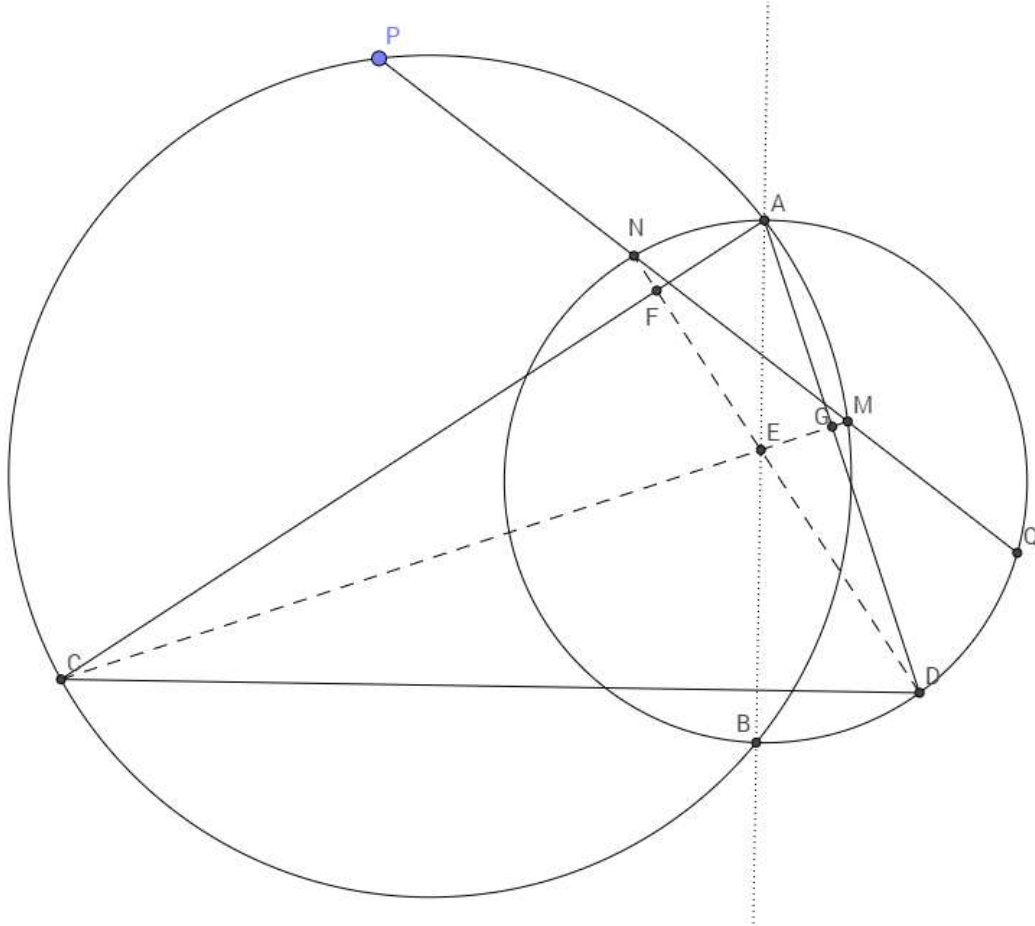

As  $AP = AQ$  the triangle  $APQ$  is isosceles, which implies  $\angle APQ = \angle AQP$ .

Angles over the same chord  $AM$  of  $C_1$  imply  $\angle ACM = \angle APM$ .

As  $C$  is the midpoint of the chord  $BP$ , we have  $\angle PAC = \angle CAB$ , analogously  $\angle DAQ = \angle BAD$ .

This implies that  $2\angle CAD = \angle PAQ$ .

Combining the results above we get as sum of the angles in triangle  $APQ$  that  $2\angle CAD + 2\angle APQ = 180^\circ$  which in turn implies  $\angle ACN + \angle DAC = 90^\circ$  and in particular  $AD \perp CM$ . Analogously we conclude  $DN \perp AC$ .

We now conclude that this implies  $E$  is the orthocenter of the triangle  $ACD$  implying  $AE \perp CD$  completing the proof.

**Second Solution.** As  $AP = AQ$  the triangle  $APQ$  is isosceles, which implies  $\angle APQ = \angle AQP$ .

Angles over the same chord  $AM$  of  $C_1$  imply  $\angle MBA = \angle APM$ , analogously this implies  $\angle ABM = \angle APQ$

Combining the above we conclude  $\angle MBA = \angle NBA$  so in particular  $AB$  is angle bisector of  $\angle MBN$ .

As  $C$  is the midpoint of the arc  $BP$  we have  $\angle PMC = \angle BMC$ .

We note this implies  $E$  lies on 2 angle bisectors of the triangle  $BNM$ , so is its incenter.

This implies that  $A, E, B$  are collinear.

We are now able to remove  $M, N, E$  from the picture and it is enough to show  $CD \perp AB$ . Let  $\alpha = \angle CAB$  and  $\beta = \angle BAD$ . Then this is equivalent to  $AC \cdot \cos \alpha = AD \cdot \cos \beta$ .

Ptolomey's theorem for cyclic quadrilateral  $APCB$  implies that

$$AC = \frac{BC \cdot AP + AB \cdot CP}{BP} = \frac{BC(AP + AB)}{2 \cos \alpha \cdot BC}$$

After simplifying and taking an analogous equality for  $C_2$  and cyclic quadrilateral  $ABDC$  gives

$$AC \cos \alpha = \frac{AP + AB}{2} = \frac{AQ + AB}{2} = AD \cos \beta$$

completing the proof.

*Remark:* Note that we are using only the very basic trigonometry, namely for a right angled triangle ( $BP = 2 \cos \alpha \cdot BC$  follows by taking the midpoint of  $BP$  and considering 2 right-angled triangles this creates.) This can be altogether avoided using similar triangles.

**Problem 3.** Prove that for all positive integers  $n$  there exist  $n$  distinct, positive rational numbers with sum of their squares equal to  $n$ .

(*Daniyar Aubekarov*)

**First Solution.** We will prove this claim by induction. For basis, we find solutions for  $n = 1, 2, 3$ :

$$1^2 = 1, \left(\frac{1}{5}\right)^2 + \left(\frac{7}{5}\right)^2 = 2, 1, 1^2 + \left(\frac{1}{5}\right)^2 + \left(\frac{7}{5}\right)^2 = 3.$$

Now, let us assume that for all integers less than  $n$  the claim is true. Let us prove the claim for  $n$ . If  $n = 4k$  for some integer  $k$ , then, by induction hypothesis, there exist rationals  $x_1, \dots, x_k$  such that

$$\begin{aligned} x_1^2 + \dots + x_k^2 &= k. \\ \implies (2x_1)^2 + \dots + (2x_k)^2 &= 4k. \end{aligned}$$

Let  $a$  be the smallest rational number from the left hand side of the above equation. We will replace this number with numbers

$$\frac{3}{5}a, \frac{4}{5}a.$$

By this, we get one more summand on the left hand side, but the equality still holds. Since  $a$  was the smallest and  $\frac{3}{5}a < \frac{4}{5}a < a$ , all rationals are still distinct. We will continue this procedure until we get  $n = 4k$  rationals.

Before we continue, notice the following: let those  $n = 4k$  rationals denote with

$$\frac{p_1}{q_1}, \dots, \frac{p_n}{q_n},$$

where  $GCD(p_i, q_i) = 1$ , for all  $1 \leq i \leq n$ . Then, all  $p_1, \dots, p_n$  are even numbers. That is because of multiplying first  $k$  rationals with 4, and because of the fact that multiplying rationals with  $\frac{4}{5}$  and  $\frac{3}{5}$  cannot turn even numerator to the odd numerator.

Now, we observe the case  $n \neq 4k$ . We will use a combination of solution for  $n = 4k$  and for  $n = 1, 2, 3$ :

$$\begin{aligned} n = 4k + 1 &: \left(\frac{p_1}{q_1}\right)^2 + \dots + \left(\frac{p_n}{q_n}\right)^2 + 1^2 = n, \\ n = 4k + 2 &: \left(\frac{p_1}{q_1}\right)^2 + \dots + \left(\frac{p_n}{q_n}\right)^2 + \left(\frac{1}{5}\right)^2 + \left(\frac{7}{5}\right)^2 = n, \\ n = 4k + 3 &: \left(\frac{p_1}{q_1}\right)^2 + \dots + \left(\frac{p_n}{q_n}\right)^2 + 1^2 + \left(\frac{1}{5}\right)^2 + \left(\frac{7}{5}\right)^2 = n. \end{aligned}$$

All numbers are still distinct because first  $4k$  numbers have even numerators, while the others do not have. This concludes the induction and the proof of the problem.

**Second Solution.** Firstly, let us prove that there are infinitely many pairs of rationals such that

$$x^2 + y^2 = 2.$$

Let us take any Pythagorean triple  $(a, b, c)$ , with  $b > a$ . Then we can take  $x = \frac{b-a}{c}, y = \frac{b+a}{c}$ .

Now, we take any number  $n$ . If it is even, then we will take  $n/2$  pairs of rationals with sum of squares equal 2. If it is odd, we will take  $(n-1)/2$  of such pairs, and one number 1.

To be sure that all numbers are distinct, we can take primitive Pythagorean triples such that all of them have unique third member  $c$  of the triple.

It is clear that they are nonzero. Let us now prove that all rationals are distinct. Firstly, if  $\frac{b-a}{c} = \frac{b+a}{c}$ , that implies  $a = 0$ , which is impossible for a member of Pythagorean triple.

Let us now assume that two different primitive Pythagorean triples  $(a, b, c)$  and  $(a', b', c')$  (with  $c \neq c'$ ) generate at least two same rational numbers. Since sum of squares of those rationals is the same, another pair of rationals must be equal as well. Thus we have to have either

$$\begin{aligned} \frac{b-a}{c} = \frac{b'-a'}{c'} \text{ and } \frac{b+a}{c} = \frac{b'+a'}{c'} &\implies \frac{b-a}{b'-a'} = \frac{b+a}{b'+a'} = \frac{c}{c'} = \lambda \in \mathbb{Q}, \text{ or} \\ \frac{b-a}{c} = \frac{b'+a'}{c'} \text{ and } \frac{b+a}{c} = \frac{b'-a'}{c'} &\implies \frac{b-a}{b'+a'} = \frac{b+a}{b'-a'} = \frac{c}{c'} = \lambda \in \mathbb{Q}. \end{aligned}$$

In both cases we have  $a^2 + b^2 = c^2 = \lambda^2(c')^2 = \lambda^2((a')^2 + (b')^2)$  and  $b^2 - a^2 = \lambda^2((b')^2 - (a')^2)$ . Hence  $c^2 = \lambda^2(c')^2$ ,  $a^2 = \lambda^2(a')^2$ ,  $b^2 = \lambda^2(b')^2$ . But then, if  $\lambda = p/q$ , then either  $p \mid a, b, c$  or  $q \mid a', b', c'$  or  $\lambda = 1$ , which contradicts the fact that our triples are primitive or that  $c' \neq c$ . All in all, we get contradiction, thus all rationals are distinct.

**Problem 4.** We will call a pair of positive integers  $(n, k)$  with  $k > 1$  a *lovely couple* if there exists a table  $n \times n$  consisting of ones and zeros with following properties:

- In every row there are exactly  $k$  ones.
- For each two rows there is exactly one column such that on both intersections of that column with the mentioned rows, number one is written.

Solve the following subproblems:

- Let  $d \neq 1$  be a divisor of  $n$ . Determine all remainders that  $d$  can give when divided by 6.
- Prove that there exist infinitely many lovely couples.

*(Miroslav Marinov, Daniel Atanasov)*

**Solution.** Let us firstly prove several lemmas. Before that, notice that changing two columns or two rows of the table will not change the properties of our table.

**Lemma 1:** In every column there are exactly  $k$  ones.

*Proof:* It is impossible that one column contains  $n$  ones. If we suppose the contrary, then on the rest of the table, consisting of  $n - 1$  columns, we would have to have  $n(k - 1) \geq n$  ones such that no two ones are in the same column, which is impossible.

Thus, every column contains at least one zero. Let us now suppose that there exists a column with more than  $k$  ones. Without loss of generality, let this column be the first column, where ones are written in the first  $k + 1$  rows, and at least one digit zero, which this column must contain, is written in last row. Again, without loss of generality, let the last row contain ones in the second, third,  $\dots$ ,  $(k + 1)$ -th column.

On the intersection of 2nd column and first  $k + 1$  rows there can be at most one digit one, because, in the contrary, some two of the first  $k + 1$  rows would have first and second column in common. Same argument holds for intersection of the 3rd column and first  $k + 1$  rows,  $\dots$ ,  $(k + 1)$ -th column and first  $k + 1$  rows. Hence, on the intersection of first  $k + 1$  rows, and 2nd, 3rd,  $\dots$ ,  $(k + 1)$ -th row there are at most  $k$  ones.

However, for the last row and for every row among the first  $k + 1$  rows, there must exist exactly one column such that both rows contain digit one in that column. This is only possible if those ones are on the intersection of first  $k + 1$  rows, and 2nd, 3rd,  $\dots$ ,  $(k + 1)$ -th row. Thus, in the mentioned zone there must be exactly  $k + 1$  ones, which leads to contradiction.

Thus we conclude that every column contains at most  $k$  digits one. Since the whole table consists of  $nk$  digits one, we have that every column contains exactly  $k$  digits one.

**Lemma 2:** We have  $n = k^2 - k + 1$ .

*Proof:* Let us count the pairs of ones in the same column. On the one hand, since there are  $n$  columns, every column contains  $k$  ones, there are

$$n \binom{k}{2}$$

pairs of ones in the same column. On the other hand, every pair of ones from the same column determine exactly one pair of rows, since each pair of rows has exactly one column in common. Thus, the number of pairs of ones from the same column is also equal to

$$\binom{n}{2}.$$

Identifying mentioned two expressions we get  $n = k^2 - k + 1$ .

Now, we will prove the problem.

**Solution of a) part:** When varying  $k$ , we see that  $n \equiv 1 \pmod{6}$  or  $n \equiv 3 \pmod{6}$ . Both options are possible, see examples for  $k = 2, k = 3$  below.

```

1110000
1001100
1000011
0101010
110 0100101
101 0011001
011 0010110

```

Let  $q$  be a prime divisor of the number  $n = k^2 - k + 1$ . Since  $n$  is odd,  $q$  is odd as well, thus possible remainders modulo 6 are 1, 3, 5. We will prove that remainder 5 is not possible. Let us suppose that  $q = 6t + 5$ . Then, since  $q \mid k^3 + 1 = (k + 1)(k^2 - k + 1)$  we have  $k^3 \equiv -1 \pmod{q}$ . On the other hand, we have  $k^{q-1} = k^{6t+4} \equiv 1 \pmod{q}$ . From those last two identities we get  $k \equiv -1 \pmod{q} \implies n \equiv 3 \pmod{q}$ , i.e.  $q \mid 3$ , contradiction.

Let  $d$  be any divisor of the number  $n$ . From above, it is either 1 or a product of prime numbers of the form  $6t + 1$  and 3. Anyhow, we have that remainder of  $d$  when divided by six is either 1 or 3.

**Solution of b) part:** We will prove that for any prime  $p$ , the pair of numbers  $(p^2 + p + 1, p + 1)$  is a lovely couple. Let us denote with  $A(i, j)$  the number in the table on the intersection of the  $i$ -th row and  $j$ -th column, with the convention that we count rows and columns from the zero in this part of the solution.

We define our table in the following way (example for  $p = 5$  is at the end)

**Rule a** For  $\alpha, \beta, \gamma \in \{0, \dots, p - 1\}$  we have

$$A(\alpha p + \beta, \gamma p + \delta) = 1 \iff \delta \equiv \alpha \gamma + \beta \pmod{p},$$

**Rule b**  $A(p^2 + \alpha, \alpha p + \beta) = 1$ , for all  $\alpha \in \{0, \dots, p\}$ ,  $\beta \in \{0, \dots, p - 1\}$ ,

**Rule c**  $A(\alpha p + \beta, p^2 + \alpha) = 1$ , for all  $\alpha \in \{0, \dots, p\}$ ,  $\beta \in \{0, \dots, p - 1\}$ ,

**Rule d**  $A(p^2 + p, p^2 + p) = 1$ ,

**Rule e** On all other unmentioned fields are zero.

Let us prove that this table has all properties. Firstly, let us prove that in every row there is exactly  $p + 1$  ones.

Case 1: In  $i$ -th row,  $i < p^2$ :  $i = \alpha p + \beta$ , for some  $0 \leq \alpha, \beta \leq p - 1$ . Then for every  $\gamma \in \{0, \dots, p - 1\}$  there exists exactly one  $\delta \in \{0, \dots, p - 1\}$  such that  $\delta \equiv \alpha \gamma + \beta \pmod{p} \implies$  there are exactly  $p$  digits one in first  $p^2$  columns. Last digit  $k$  is in the column  $p^2 + \alpha$ , according to the Rule c.

Case 2: In  $i$ -th row,  $i \geq p^2$ :  $i = p^2 + \alpha$ , for some  $0 \leq \alpha \leq p$ . Those ones are written in the columns (according to the Rule b)  $\alpha p + 0, \dots, \alpha p + p - 1$  and (according to the Rule c or d) in the last column.

In the same manner it can be proved that every column contains exactly  $p + 1$  ones. Thus, it is sufficient to prove that every two rows have at least one column in common.

Case 1:  $i, j \geq p^2$ :  $i = p^2 + \alpha_i, j = p^2 + \alpha_j$  for some  $0 \leq \alpha_i, \alpha_j \leq p$ . According to the Rule c or d:  $A(i, p^2 + p) = A(j, p^2 + p) = 1$ .

Case 2:  $i < p^2, j = p^2 + p$ :  $i = \alpha_i p + \beta_i$  for some  $0 \leq \alpha_i \leq p, 0 \leq \beta_i \leq p - 1$ . According to the Rule c we have  $A(i, p^2 + \alpha_i) = 1$ , and according to the Rule b:  $A(j, p^2 + \alpha_i) = 1$ .

From now on, all mentioned variables  $\alpha_i, \alpha_j, \beta_i, \beta_j, \gamma, \delta$  are from the set  $\{0, \dots, p - 1\}$ .

Case 3:  $i < p^2, p^2 \leq j < p^2 + p$ :  $i = \alpha_i p + \beta_i, j = p^2 + \alpha_j$ . According to Rule a, there is exactly one  $\delta$  such that  $A(i, \alpha_j p + \delta) = 1$ . According to the Rule b:  $A(j, \alpha_j p + \delta) = 1$ .

Case 4a:  $i, j < p^2$ :  $i = \alpha_i p + \beta_i, j = \alpha_j p + \beta_j$  with  $\alpha_i = \alpha_j := \alpha$ . According to the Rule c:  $A(i, p^2 + \alpha) = A(j, p^2 + \alpha) = 1$ .

Case 4b:  $i, j < p^2$ :  $i = \alpha_i p + \beta_i, j = \alpha_j p + \beta_j$  with  $\alpha_i \neq \alpha_j := \alpha$ . Let us define

$$\gamma = (\alpha_i - \alpha_j)^{-1}(\beta_j - \beta_i).$$

It is clear that then we have  $\alpha_i \gamma + \beta_i = \alpha_j \gamma + \beta_j =: \delta$ . According to the Rule a:  $A(i, \gamma p + \delta) = A(j, \gamma p + \delta) = 1$ .

1 1 1 1 1	1 1 1 1 1	1 1 1 1 1	1 1 1 1 1	1 1 1 1 1	1 1 1 1 1
1 1 1 1 1	1 1 1 1 1	1 1 1 1 1	1 1 1 1 1	1 1 1 1 1	1 1 1 1 1
1 1 1 1 1	1 1 1 1 1	1 1 1 1 1	1 1 1 1 1	1 1 1 1 1	1 1 1 1 1
1 1 1 1 1	1 1 1 1 1	1 1 1 1 1	1 1 1 1 1	1 1 1 1 1	1 1 1 1 1
1 1 1 1 1	1 1 1 1 1	1 1 1 1 1	1 1 1 1 1	1 1 1 1 1	1 1 1 1 1
1 1 1 1 1	1 1 1 1 1	1 1 1 1 1	1 1 1 1 1	1 1 1 1 1	1 1 1 1 1 1

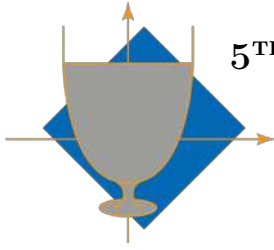

5<sup>TH</sup> EUROPEAN MATHEMATICAL CUP  
3<sup>rd</sup> December 2016–11<sup>th</sup> December 2016  
Senior Category



**Problem 1.** Is there a sequence  $a_1, \dots, a_{2016}$  of positive integers, such that every sum

$$a_r + a_{r+1} + \dots + a_{s-1} + a_s$$

(with  $1 \leq r \leq s \leq 2016$ ) is a composite number, but

- a)  $GCD(a_i, a_{i+1}) = 1$  for all  $i = 1, 2, \dots, 2015$ ;
- b)  $GCD(a_i, a_{i+1}) = 1$  for all  $i = 1, 2, \dots, 2015$  and  $GCD(a_i, a_{i+2}) = 1$  for all  $i = 1, 2, \dots, 2014$ ?

$GCD(x, y)$  denotes the greatest common divisor of  $x, y$ .

(Matija Bucić)

**Problem 2.** For two positive integers  $a$  and  $b$ , Ivica and Marica play the following game: Given two piles of  $a$  and  $b$  cookies, on each turn a player takes  $2n$  cookies from one of the piles, of which he eats  $n$  and puts  $n$  of them on the other pile. Number  $n$  is arbitrary in every move. Players take turns alternatively, with Ivica going first. The player who cannot make a move, loses. Assuming both players play perfectly, determine all pairs of numbers  $(a, b)$  for which Marica has a winning strategy.

(Petar Orlić)

**Problem 3.** Determine all functions  $f : \mathbb{R} \rightarrow \mathbb{R}$  such that equality

$$f(x + y + yf(x)) = f(x) + f(y) + xf(y)$$

holds for all real numbers  $x, y$ .

(Athanasios Kontogeorgis)

**Problem 4.** Let  $C_1, C_2$  be circles intersecting in  $X, Y$ . Let  $A, D$  be points on  $C_1$  and  $B, C$  on  $C_2$  such that  $A, X, C$  are collinear and  $D, X, B$  are collinear. The tangent to circle  $C_1$  at  $D$  intersects  $BC$  and the tangent to  $C_2$  at  $B$  in  $P, R$  respectively. The tangent to  $C_2$  at  $C$  intersects  $AD$  and tangent to  $C_1$  at  $A$ , in  $Q, S$  respectively. Let  $W$  be the intersection of  $AD$  with the tangent to  $C_2$  at  $B$  and  $Z$  the intersection of  $BC$  with the tangent to  $C_1$  at  $A$ . Prove that the circumcircles of triangles  $YWZ, RSY$  and  $PQY$  have two points in common, or are tangent in the same point.

(Misiakos Panagiotis)

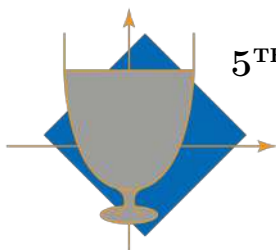

5<sup>TH</sup> EUROPEAN MATHEMATICAL CUP  
3<sup>rd</sup> December 2016–11<sup>th</sup> December 2016  
Senior Category



## Problems and Solutions

**Problem 1.** Is there a sequence  $a_1, \dots, a_{2016}$  of positive integers, such that every sum

$$a_r + a_{r+1} + \dots + a_{s-1} + a_s$$

(with  $1 \leq r \leq s \leq 2016$ ) is a composite number, but

- a)  $GCD(a_i, a_{i+1}) = 1$  for all  $i = 1, 2, \dots, 2015$ ;
- b)  $GCD(a_i, a_{i+1}) = 1$  for all  $i = 1, 2, \dots, 2015$  and  $GCD(a_i, a_{i+2}) = 1$  for all  $i = 1, 2, \dots, 2014$ ?

$GCD(x, y)$  denotes the greatest common divisor of  $x, y$ .

(Matija Bucić)

**First Solution.** We will solve this problem for any length  $n$  of the sequence.

- a) Yes, there is such sequence.

For this part, we will construct solution by taking  $n$  consecutive positive integers  $a_i = m + i$ , for some positive integer  $m$ . We will determine number  $m$  at the end of the proof.

Firstly, notice that two consecutive elements of the sequence are coprime, since they are consecutive numbers. Every sum of consecutive members of sequence is of the form

$$(a+1) + (a+2) + \dots + (b-1) + b = \frac{b(b+1)}{2} - \frac{a(a+1)}{2} = \frac{(b-a)(b+a+1)}{2}.$$

For  $b \geq a+3$ , numerator of the expression above consists of two factors, each greater or equal to 3, and at least one of them is even, thus number is composite.

Thus, we have to choose  $m$  such that all sums of one and all sums of two consecutive members of sequence are composite. That is, following numbers need to be composite:

$$m+1, m+2, \dots, m+n, 2m+3, 2m+5, \dots, 2m+(2n-1).$$

This is achieved for  $m = (2n+1)! + 1$ . Namely, numbers  $(2n+1)! + k$  and  $2 \cdot (2n+1)! + k$  are composite for all  $2 \leq k \leq 2n+1$  since they are divisible by  $k$ , and greater than  $k$ .

- b) Again, the answer is yes.

Similarly like in first part, we will take some  $n$  consecutive odd numbers:  $a_i = 2m + (2i-1)$ , for some positive integer  $m$ .

It is clear that they are integers, and they are positive.

We will have  $GCD(a_i, a_{i+1}) = GCD(a_i, a_{i+2}) = 1$  because differences of mentioned numbers are always 2 or 4. Since numbers are odd, they have to be coprime.

Every sum of consecutive members of sequence is of the form

$$(2a+1) + (2a+3) + \dots + (2b-3) + (2b-1) = b^2 - a^2 = (b-a)(b+a).$$

For  $b \geq a+2$  number from above is composite because both factors are greater or equal to 2.

Thus, we have to choose  $m$  such that all numbers

$$2m+1, 2m+3, \dots, 2m+(2n-1)$$

are composite. This is achieved by taking  $m = (2n)! + 1$ , with similar arguments like in first part.

**Second Solution. (For part b) only.)**

We will show that there exists a sequence for b) part of the problem.

It is obvious that this will imply that the answer for the a) part of the solution is yes.

We will form the sequence by induction. For the basis, we will take  $a_1 = 4$ ,  $a_2 = 35$ . Those numbers are composite, their sum is composite and they are coprime.

Let us assume that we have  $n$  positive integers with properties from the text of the problem. Let  $p_1, p_2, \dots, p_n, p_{n+1}$  be some prime numbers greater than

$$a_1 + a_2 + \dots + a_n.$$

Notice that this immediately means that those primes are greater than any sum of consecutive numbers, and specially, that all those sums (including solely integers  $a_i$ ) are coprime with mentioned primes.

We will get  $a_{n+1}$  by solving system of modular equations. Existence of such positive integer is provided by Chinese remainder theorem. The system is the following:

$$\begin{aligned} a_{n+1} &\equiv 1 \pmod{a_n}, \quad a_{n+1} \equiv 1 \pmod{a_{n-1}}, \\ a_{n+1} &\equiv -(a_n + \dots + a_{n-k}) \pmod{p_k}, \quad k = 0, 1, 2, \dots, n-1 \\ a_{n+1} &\equiv 0 \pmod{p_{n+1}}. \end{aligned}$$

In first row we provided that  $GCD(a_{n+1}, a_n) = GCD(a_{n+1}, a_{n-1}) = 1$ .

In second two rows we provided that all sums of consecutive numbers including  $a_{n+1}$  are composite.

Chinese remainder theorem can be applied here since all primes are greater than  $a_n$  and  $a_{n-1}$ , and thus they are coprime.

**Third Solution. (For part b) only.)** As before, it is sufficient to prove the existence of the sequence for b) part only.

We will form recursion:  $a_{-1} = 1, a_0 = 3, a_k = a_{k-1}^2 - a_{k-2}^2$ , for  $k \geq 1$ . (Here values  $a_{-1}$  and  $a_0$  are just auxiliary terms).

All numbers are positive integers, moreover we will prove that  $a_k \geq a_{k-1} + 2$ , which we get from induction:

$$a_k = a_{k-1}^2 - a_{k-2}^2 \geq a_{k-1}^2 - (a_{k-1} - 2)^2 = 4a_{k-1} - 4 \geq a_{k-1} + 2,$$

since  $a_{k-1} \geq a_0 = 3$ .

If there is some index  $k$  and some prime  $p$  such that  $p$  divides  $a_k$  and  $a_{k-1}$  or divides  $a_k$  and  $a_{k-2}$ , then from equation  $a_k = a_{k-1}^2 - a_{k-2}^2$  we get that  $p$  divides  $a_{k-1}$  and  $a_{k-2}$ . In the same manner,  $p$  then divides  $a_{k-2}$  and  $a_{k-3}$ , it divides  $a_{k-3}$  and  $a_{k-4}$ , and so on, thus it divides  $a_{-1}$  and  $a_0$ , which is impossible.

Let us now prove that all sums of consecutive elements are composite:

$$a_r + \dots + a_s = (a_{r-1}^2 - a_{r-2}^2) + \dots + (a_{s-1}^2 - a_{s-2}^2) = a_{s-1}^2 - a_{r-2}^2 = (a_{s-1} - a_{r-2})(a_{s-1} + a_{r-2}).$$

First factor is greater than 1 since  $a_{s-1} \geq a_{r-1} \geq a_{r-2} + 2$ . Second factor is clearly greater than 1, hence the product is composite.

**Fourth Solution. (For part a) only.)**

The answer is yes.

Similarly like in the first solution, we will take sequence of consecutive third powers of positive integers:  $a_i = (i+1)^3$ .

Like in first solution, consecutive elements are coprime. It is clear that all numbers are positive integers.

All possible sums of consecutive elements are of the form

$$\begin{aligned} (a+1)^3 + (a+2)^3 + \dots + (b-1)^3 + b^3 &= \left(\frac{b(b+1)}{2}\right)^2 - \left(\frac{a(a+1)}{2}\right)^2 = \left(\frac{b(b+1)}{2} - \frac{a(a+1)}{2}\right) \left(\frac{b(b+1)}{2} + \frac{a(a+1)}{2}\right) = \\ &= ((a+1) + (a+2) + \dots + (b-1) + b) \left(\frac{b(b+1)}{2} + \frac{a(a+1)}{2}\right). \end{aligned}$$

Second factor is greater or equal than first one. Second is greater than 1 if all elements of sequence are greater than 1. Since we chose numbers in that way, the number is composite.

**Problem 2.** For two positive integers  $a$  and  $b$ , Ivica and Marica play the following game: Given two piles of  $a$  and  $b$  cookies, on each turn a player takes  $2n$  cookies from one of the piles, of which he eats  $n$  and puts  $n$  of them on the other pile. Number  $n$  is arbitrary in every move. Players take turns alternatively, with Ivica going first. The player who cannot make a move, loses. Assuming both players play perfectly, determine all pairs of numbers  $(a, b)$  for which Marica has a winning strategy.

(Petar Orlić)

**Solution.** Marica wins the game if  $|a - b| \leq 1$ , otherwise Ivica wins.

We will say that a player is in a losing position if it is his turn and  $|a - b| \leq 1$ , while calling all other positions winning positions. It is easy to see that the only positions in which one cannot make a move are  $(0, 0), (0, 1), (1, 0), (1, 1)$  and that they are all losing positions.

**Claim 1.** *If a player is in a losing position, then regardless of his move he must leave a winning position for the other player.*

*Proof.* If the piles are of sizes  $x$  and  $x + 1$ , then after a move they will have sizes  $x - 2k$  i  $x + k + 1$  (their difference is  $3k + 1$ ) or  $x + k$  i  $x - 2k + 1$  (their difference is  $3k - 1$ ). In both cases, the difference is at least 2. If the piles have  $x$  and  $x$  cookies each, then after a move they will have  $x - 2k$  and  $x + k$  cookies (there difference is  $3k$ , which is at least 3). Since the difference of the number of cookies is always bigger than 1, we have proven that this is a winning position.  $\square$

**Claim 2.** *A player who is in a winning position can always leave a losing position after his turn.*

*Proof.* If the piles are of sizes  $x$  and  $x + 3a$  (where  $a \geq 0$ ), one can take  $2a$  cookies from the second pile and and leave two piles containing  $x + a$  and  $x + a$  cookies. If the piles are of sizes  $x$  and  $x + 3a + 1$  (where  $a \geq 0$ ), one can take  $2a$  cookies from the second pile and leave two piles containing  $x + a$  and  $x + a + 1$  cookies.

If the piles are of sizes  $x$  and  $x + 3a - 1$  (where  $a \geq 0$ ), one can take  $2a$  cookies from the second pile and and leave two piles containing  $x + a$  and  $x + a - 1$  cookies. Since the difference in each case is less than 2, thus a player can always leave a losing position if he is in a winning position.  $\square$

We have now proven that if Ivica is in a losing position in the begging, Marica can always ensure that he is in a winning position and win. Similarly, if Ivica is in a winning position in the begging, he can always ensure that he is in a winning position and win. So, Marica wins only when Ivica is in a losing position in his first turn. This is true only when  $|a - b| \leq 1$ .

**Problem 3.** Determine all functions  $f : \mathbb{R} \rightarrow \mathbb{R}$  such that equality

$$f(x + y + yf(x)) = f(x) + f(y) + xf(y)$$

holds for all real numbers  $x, y$ .

(Athanasios Kontogeorgis)

**Solution.** We easily see that  $f(x) = 0, x \in \mathbb{R}$  and  $f(x) = x, x \in \mathbb{R}$  are solutions. Let us assume that  $f$  satisfies the given equation but is not a constant or identity.

Throughout the proof, we denote by  $(x_0, y_0)$  the initial equation with  $x = x_0, y = y_0$ .

Then,  $(-1, y)$  implies  $f(-1 + y(1 + f(-1))) = f(-1)$ . Let us assume that  $1 + f(-1) = c \neq 0$ . Then, for any  $cy - 1$  achieves all real numbers and hence  $f(z) = f(-1) \forall z \in \mathbb{R}$  so  $f$  is a constant, a contradiction. Hence,  $f(-1) = -1$ .

Let us assume that there is some  $\alpha \in \mathbb{R}$  such that  $f(\alpha) = -1$ , but  $\alpha \neq -1$ . Then,  $(\alpha, y) : f(\alpha) = f(\alpha) + f(y) + \alpha f(y) \implies 0 = f(y)(1 + \alpha)$ . Since  $\alpha \neq -1$ , we get  $f(y) = 0, y \in \mathbb{R}$ , a contradiction. Thus, we have shown

$$f(x) = -1 \iff x = -1 \tag{1}$$

$$(x, -1) : f(x - 1 - f(x)) = f(x) - 1 - x. \tag{2}$$

Since we assumed that  $f$  is not the identity, there exists a real number  $x_0$  such that  $f(x_0) \neq x_0$ . We set  $a := f(x_0) - x_0 \neq 0$ . Putting  $x = x_0$  in the above equation gives:

$$f(-1 - a) = a - 1. \tag{3}$$

We get from  $(-1 - a, y) :$  and equation (3)

$$f(-1 - a + ya) = a - 1 - af(y). \tag{4}$$

If we now put  $y = 1$ , we get  $a(1 - f(1)) = 0$  so as  $a \neq 0$  we get  $f(1) = 1$ .

Now  $(1, 1)$  gives us  $f(3) = 3$ .

Putting  $(1, y - 1)$  gives us

$$f(2y - 1) = 2f(y - 1) + 1. \tag{5}$$

Using  $f(3) = 3$  in (3) with  $y = 3$  we get  $f(2a - 1) = -2a - 1$ , while using  $y = a$  in (5) we get  $f(2a - 1) = 2f(a - 1) + 1$ , combining the two gives us

$$f(a - 1) = -1 - a. \tag{6}$$

We get from  $(a - 1, 2 - y) :$

$$f(-a - 1 + ay) = -1 - a + af(2 - y). \tag{7}$$

Combining this with (4) we get:

$$a(f(y) + f(2 - y) - 2) = 0. \tag{8}$$

So as  $a \neq 0$ , we get  $f(y) + f(2 - y) = 2$  for all  $y$ .

Putting  $y = 1 + 2x$  here, gives  $f(1 + 2x) + f(1 - 2x) = 2$ , which when combined with 5 with  $y = x + 1$  gives,  $f(1 - 2x) = 1 - 2f(x)$ .

While (5) for  $y = 1 - x$  gives  $f(1 - 2y) = 1 + 2f(-y)$ , which combined with the above implies  $f(-x) = -f(x)$  for all  $x$ . Let us put  $(x, -y)$  in initial equation, and then subtract the original equation (for  $(x, y)$ ). We obtain:

$$f(x + y(1 + f(x))) + f(x - y(1 + f(x))) = 2f(x). \tag{9}$$

We substitute  $y$  with

$$\frac{y}{1 + f(x)}$$

and get

$$f(x + y) + f(x - y) = 2f(x), \tag{10}$$

which is valid for all  $x, y$ , with  $f(x) + 1 \neq 0 \iff x \neq -1$ . But, from  $f$  being odd and (8), we see that this is valid for  $x = -1$ , as well. In (10) we put  $x = y$  to obtain  $f(2x) = 2f(x)$ . In the same equation we put  $\frac{x-y}{2}, \frac{x+y}{2}$  and obtain

$$f(x) + f(y) = f(x + y). \tag{11}$$

Using this additivity, we can simplify the original equation:

$$f(xf(y)) = yf(x) \tag{12}$$

In the last equation we can firstly put  $(1, y) \implies f(f(y)) = y$  and secondly  $f(y)$  instead of  $y$ :  $f(xy) = f(x)f(y)$ .

It is well known that from identities  $f(1) = 1, f(xy) = f(x)f(y)$  and  $f(x + y) = f(x) + f(y)$  we can conclude that  $f(x) = x$ . Which is a contradiction.

For the well known claim, we notice that  $f(x^2) = f(x)^2$  implies  $f(x) \geq 0$  for  $x \geq 0$ , which implies, combined with  $f(x + y) = f(x) + f(y)$  that  $f$  is non-decreasing which in turn is enough to combine with the standard density of rationals argument to solve Cauchy's equation.

Hence, the functions presented at the start give all possible solutions.

**Problem 4.** Let  $C_1, C_2$  be circles intersecting in  $X, Y$ . Let  $A, D$  be points on  $C_1$  and  $B, C$  on  $C_2$  such that  $A, X, C$  are collinear and  $D, X, B$  are collinear. The tangent to circle  $C_1$  at  $D$  intersects  $BC$  and the tangent to  $C_2$  at  $B$  in  $P, R$  respectively. The tangent to  $C_2$  at  $C$  intersects  $AD$  and tangent to  $C_1$  at  $A$ , in  $Q, S$  respectively. Let  $W$  be the intersection of  $AD$  with the tangent to  $C_2$  at  $B$  and  $Z$  the intersection of  $BC$  with the tangent to  $C_1$  at  $A$ . Prove that the circumcircles of triangles  $YWZ, RSY$  and  $PQY$  have two points in common, or are tangent in the same point.

(Misiakos Panagiotis)

**Solution.** We present the following sketch:

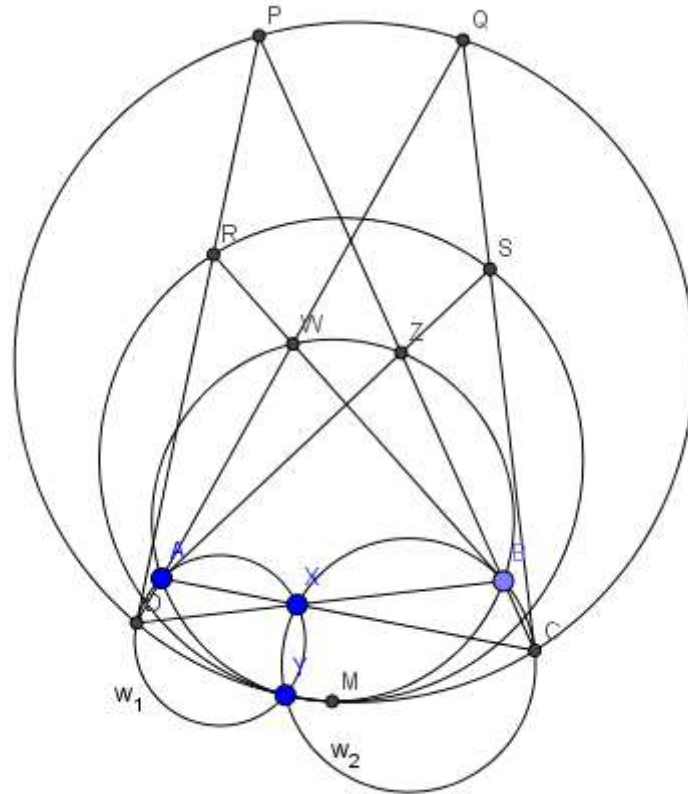

Consider  $K, L$  the intersections of the pairs of tangents at  $(A, D)$  to  $C_1$  and  $(B, C)$  to  $C_2$  respectively.

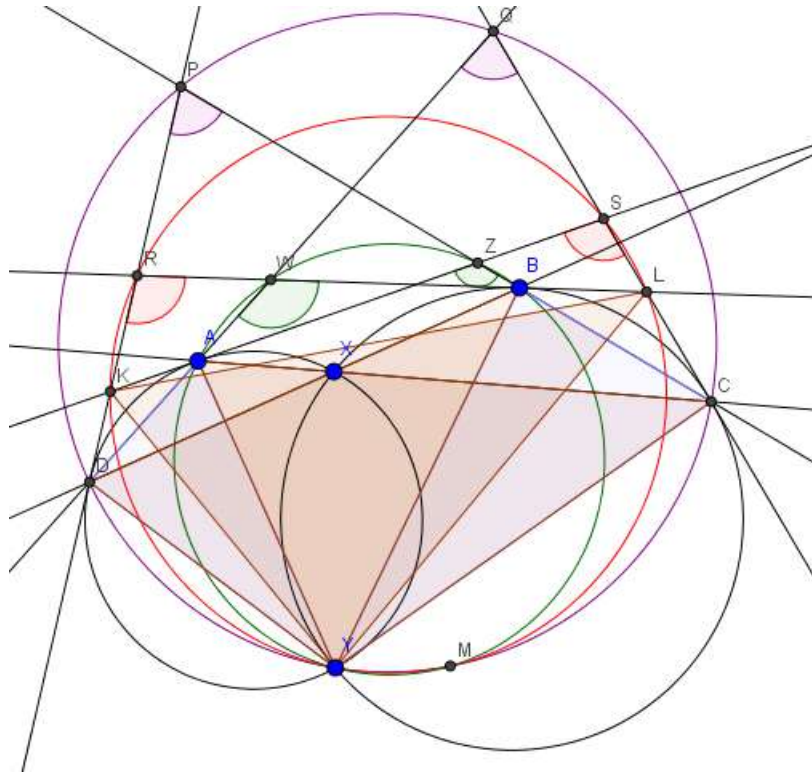

Notice that  $\angle WAZ = \angle KAD = \angle AXD = \angle BXC = \angle LBC = \angle ZBW$ . So  $WZBA$  is a cyclic quadrilateral. Furthermore,  $\angle AZB = \angle AZC = 180^\circ - \angle ZAC - \angle ZCA = 180^\circ - \angle AYX - \angle BYX = 180^\circ - \angle AYB$ . Thus the circle from  $A, Y, B$  passes from  $Z$ , and since  $W, Z, B, A$  are concyclic  $W, Z, B, Y, A$  belong to the same circle.

Analogous angle chase gives  $P, Q, C, Y, D$  concyclic.

$K, Y, L, S, R$  are also concyclic, this follows from  $\angle ASC = 180^\circ - \angle SAC - \angle SCA = 180^\circ - \angle AYC$ .

We have,  $\angle XDY = \angle XAY$  and  $\angle YBX = \angle YCX$  which implies  $\triangle DYB \sim \triangle YAC$ . This implies  $\angle DYB = \angle AYC$ .

We have  $\angle DRB = 180^\circ - \angle RDB - \angle DBR = 180^\circ - \angle DYX - \angle XYB = 180^\circ - \angle DYB = 180^\circ - \angle AYC = 180^\circ - \angle AYX - \angle XYC = 180^\circ - \angle XCS - \angle XAS = \angle ASC$ . This implies  $KRSL$  is cyclic.

$\triangle DYB \sim \triangle YAC$  also implies  $\angle DYA = \angle BYC$ , as well as  $\frac{DY}{AY} = \frac{YB}{YC}$  which implies  $\triangle DYA \sim \triangle BYC$ . This further implies the isosceles triangles  $AKD$  and  $LBC$  have same angles so quadrilaterals  $DYAK$  and  $BYCL$  are also similar, in particular implying  $\angle KYD = \angle LYB$ . This in turn implies  $180^\circ - \angle DRL = \angle DYB = \angle KYL$  which in turn implies  $Y$  is on the same circle as  $K, R, S, L$ .

We now proceed to show circumcircles of  $YKL, YDC, YAB$  have two common points.

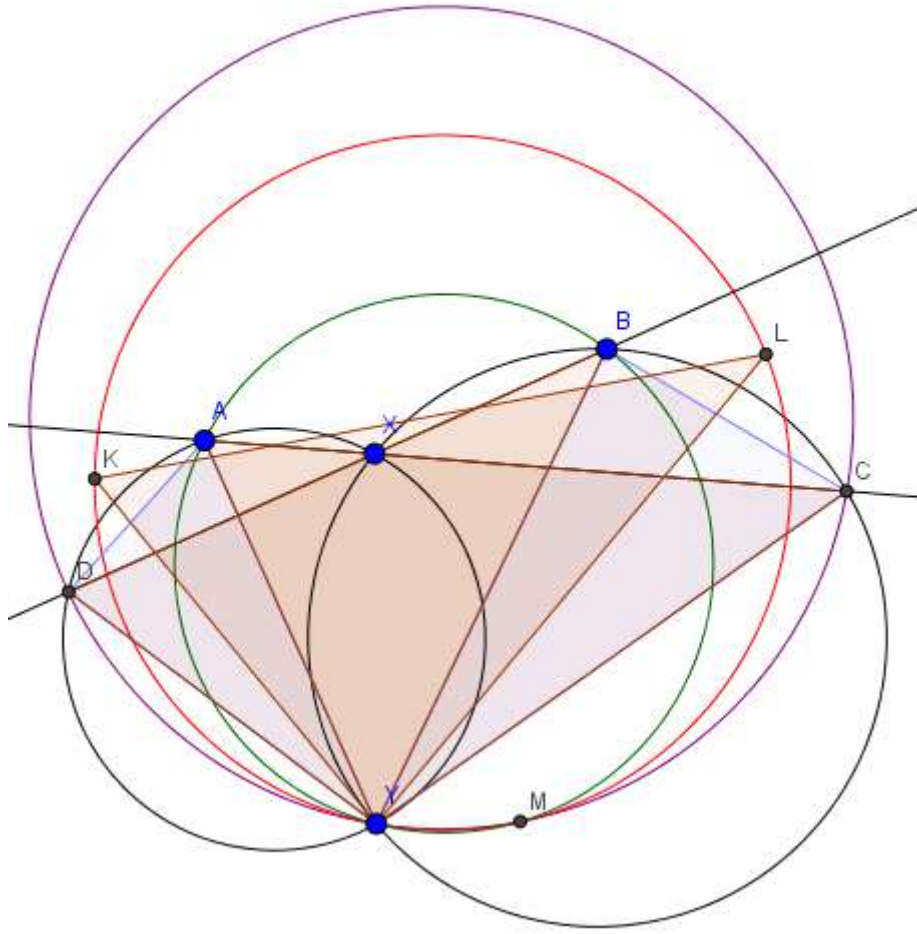

Let  $F, J$  be the points of intersections of  $AC, BD$  with circle  $DYC$  respectively and  $G, I$  be the points of intersection of  $BD, AC$  with circle  $ABY$ .

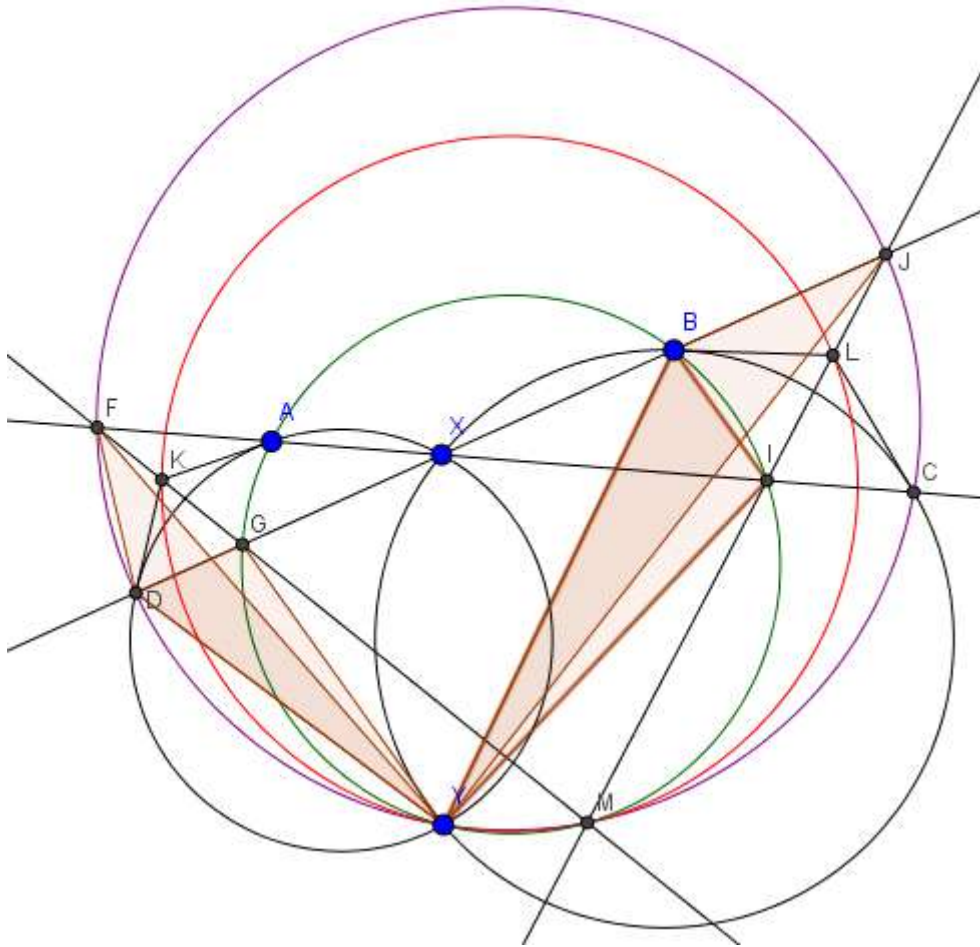

Now let  $M$  be the intersection of lines  $FG, JI$ . We will eventually prove that this will be a second common point for the three circles.

First we show that the  $FDY, BJY$  are similar. For this note that  $\angle FXJ = \angle XJC + \angle XCJ = \angle FYJ + \angle DJC = \angle FYJ + 180^\circ - \angle DYC \implies \angle FYJ = \angle FXJ - 180^\circ + \angle DYC = \angle DYC - \angle AXD = \angle AYC = \angle DYB$ . Thus  $\angle FYJ = \angle DYB$  and so  $\angle FYD \sim \angle JYB$ . While  $\angle DJY = \angle DFY$  showing  $\triangle FDY \sim \triangle JBY$  as claimed.

Also  $\triangle DGY \sim \triangle BIY$  are similar, since  $\angle AXB = \angle XBI + \angle BIX = \angle XBI + \angle AYB = 180^\circ - \angle GYI + \angle AYB = 180^\circ - \angle AYG - \angle BYI \implies \angle AXD = \angle AYG + \angle IYB \implies \angle AYG + \angle GYD = \angle AYG + \angle IYB \implies \angle GYD = \angle IYB$ . Also,  $\angle BIY = \angle DGY, \angle YBI = \angle YAI = \angle YAX = \angle YDX = \angle YDG$  and we get our result.

Now we get that the spiral similarity that sends  $D \rightarrow B$  and  $F \rightarrow J$  also sends  $G \rightarrow I$ , so  $\triangle FGY \sim \triangle JIY$ , so  $\angle YGM = \angle YIM$  and  $\angle YFM = \angle YJM$ , so  $M$  belongs to both of the circumcircles of  $FYJ$  and  $GIY$ , hence  $M$  is the (other than  $Y$ ) common point of circumcircles of  $ABY$  and  $CDY$ .

Since  $\angle FMJ = \angle FYJ = \angle DYB = \angle KYL$  it remains to show that  $K, L$  belong on the Lines  $FG, JI$  respectively (then circle  $KYL$  would pass through  $M$ .)

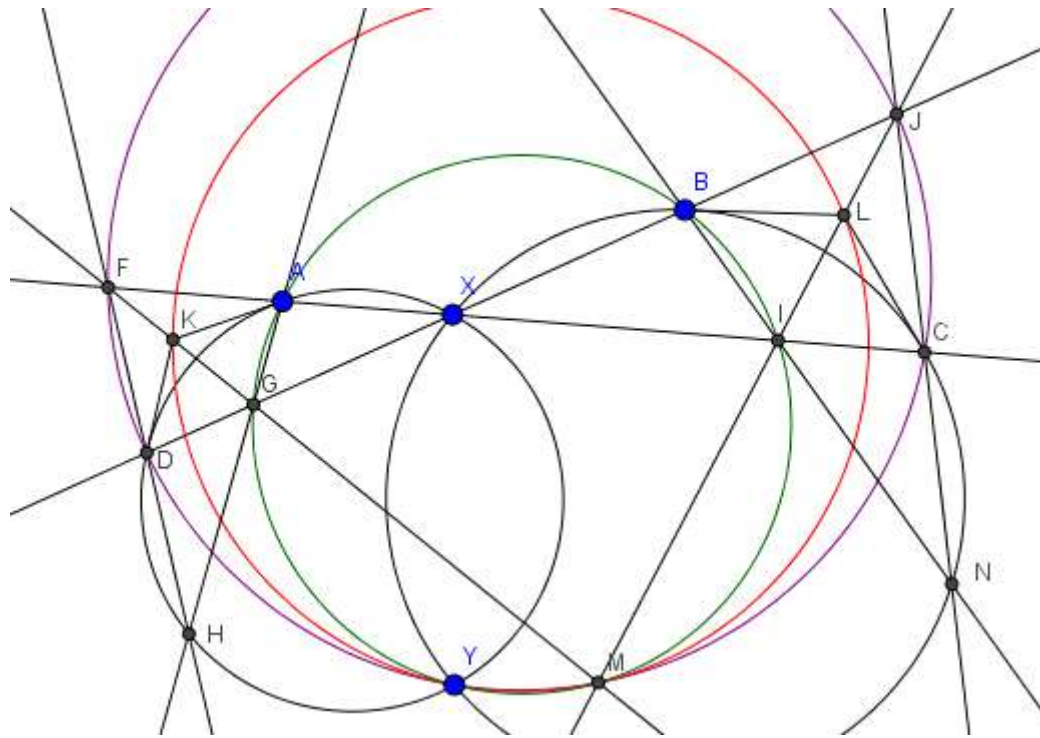

Let  $H$  denote the point of intersection of lines  $AG, FD$ . Then  $\angle HDX = 180^\circ - \angle FDX = 180^\circ - \angle FMJ = \angle GAI = \angle GAX$ , so  $H$  belongs to the circumcircle of triangle  $ADX$ .

Similarly denote  $N$  (the intersection of lines  $BI, JC$ ) and it will for analogous reasons belong to the circumcircle of  $\triangle BXC$ .

Now from Pascal's theorem for the hexagons  $AAXDDH$  and  $BBXCCN$  we derive that  $F, K, G$  as well as  $J, L, I$  are collinear. The conclusion follows.

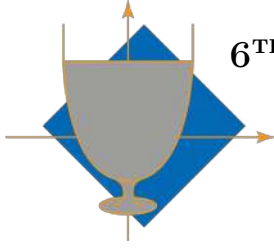

6<sup>TH</sup> EUROPEAN MATHEMATICAL CUP  
9<sup>th</sup> December 2017–17<sup>th</sup> December 2017  
Junior Category



**Problem 1.** Find all pairs  $(x, y)$  of integers that satisfy the equation

$$x^2y + y^2 = x^3.$$

(Daniel Paleka)

**Problem 2.** A regular hexagon in the plane is called *sweet* if its area is equal to 1. Is it possible to place 2000000 sweet hexagons in the plane such that the union of their interiors is a convex polygon of area at least 1900000?

*Remark:* A subset  $S$  of the plane is called *convex* if for every pair of points in  $S$ , every point on the straight line segment that joins the pair of points also belongs to  $S$ . The hexagons may overlap.

(Josip Pupić, Borna Vukorepa)

**Problem 3.** Let  $ABC$  be an acute triangle. Denote by  $H$  and  $M$  the orthocenter of  $ABC$  and the midpoint of side  $BC$ , respectively. Let  $Y$  be a point on  $AC$  such that  $YH$  is perpendicular to  $MH$  and let  $Q$  be a point on  $BH$  such that  $QA$  is perpendicular to  $AM$ . Let  $J$  be the second point of intersection of  $MQ$  and the circle with diameter  $MY$ . Prove that  $HJ$  is perpendicular to  $AM$ .

(Steve Dinh)

**Problem 4.** The real numbers  $x, y, z$  satisfy  $x^2 + y^2 + z^2 = 3$ . Prove the inequality

$$x^3 - (y^2 + yz + z^2)x + y^2z + yz^2 \leq 3\sqrt{3}$$

and find all triples  $(x, y, z)$  for which equality holds.

(Miroslav Marinov)

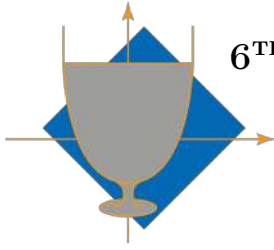

**6<sup>TH</sup> EUROPEAN MATHEMATICAL CUP**  
*9<sup>th</sup> December 2017–23<sup>rd</sup> December 2017*  
Junior Category



## Problems and Solutions

**Problem 1.** Find all pairs  $(x, y)$  of integers that satisfy the equation

$$x^2y + y^2 = x^3.$$

*(Daniel Paleka)*

**First Solution.** Firstly, let us consider the case  $x = 0$ . In that case, it is trivial to see that  $y = 0$ , and thus we get the solution  $(0, 0)$ . From now on, we can assume  $x \neq 0$ .

**1 point.**

From the trivial  $x^2|x^3$ , the equation gives  $x^2|x^2y + y^2 \Rightarrow x^2|y^2$ , which means  $x|y$ .

**1 point.**

We use the substitution  $y = kx$ , where  $k \in \mathbb{Z}$ .

**1 point.**

The substitution gives us

$$\begin{aligned} kx^3 + k^2x^2 &= x^3 \\ kx + k^2 &= x \\ k^2 &= x(1 - k) \end{aligned}$$

**2 points.**

Considering the greatest common divisor of  $k^2$  and  $1 - k$ , we get

$$GCD(k^2, 1 - k) = GCD(k^2 + k(1 - k), 1 - k) = GCD(k, 1 - k) = GCD(k, 1 - k + k) = GCD(k, 1) = 1$$

**3 points.**

That leaves us with two possibilities.

a)  $1 - k = 1 \Rightarrow k = 0 \Rightarrow x = 0$  which is not possible since  $x \neq 0$ .

**1 point.**

b)  $1 - k = -1 \Rightarrow k = 2 \Rightarrow x = -4, y = -8$ , which gives a solution to the original equation.

**1 point.**

**Second Solution.** We rearrange the equation into:

$$y^2 = x^2(x - y).$$

It can easily be shown that if  $y \neq 0$ ,  $x - y$  must be square.

**1 point.**

If  $y = 0$ , from the starting equation we infer  $x = 0$ , and we have a solution  $(x, y) = (0, 0)$ .

In the other case, we set  $x = y + a^2$ , where  $a$  is a positive integer. Taking the square root of the equation gives:

$$|y| = |x|a$$

**1 point.**

Because  $x = y + a^2 > y$ , it is impossible for  $y$  to be a positive integer, because then the equation would say  $y = xa > x$ , which is false. That means  $y < 0$ , and also:

$$-y = |x|a$$

**2 points.**

If  $x$  is positive, we can write:

$$-y = xa = (y + a^2)a = ay + a^3$$

which rearranges into

$$-y(a + 1) = a^3,$$

so  $a^3$  is divisible by  $a + 1$ , which is not possible for positive  $a$  due to  $a^3 = (a + 1)(a^2 - a + 1) - 1$ .

**2 points.**

We see that  $x$  cannot be zero due to  $y$  being negative, so the only remaining option is that  $x < 0$  also. We write:

$$-y = xa = -(y + a^2)a = -ay + a^3$$

which can similarly be rearranged into

$$-y(a - 1) = a^3,$$

and this time  $a^3$  is divisible by  $a - 1$ .

**1 point.**

Analogously, we decompose  $a^3 = (a - 1)(a^2 + a + 1) + 1$ , so  $a - 1$  divides 1 and the unique possibility is  $a = 2$ .

**2 points.**

The choice  $a = 2$  gives  $y = -8$  and  $x = -4$ , which is a solution to the original equation.

**1 point.**

#### Notes on marking:

- Points awarded for different solutions are not additive, a student should be awarded the maximal number of points he is awarded following only one of the schemes.
- Saying that  $(0, 0)$  is a solution is worth **0 points**. The point is awarded only if the student argues that, disregarding the solution  $(0, 0)$ , we must only consider  $x \neq 0$ , or a similar proposition.
- Failing to check that  $(0, 0)$  is a solution shall not be punished. Failing to check that  $(-4, -8)$  is a solution shall result in the deduction of **1 point** only if a student did not use a chain of equivalences to discover the solution.

**Problem 2.** A regular hexagon in the plane is called *sweet* if its area is equal to 1. Is it possible to place 2000000 sweet hexagons in the plane such that the union of their interiors is a convex polygon of area at least 1900000?

*Remark:* A subset  $S$  of the plane is called *convex* if for every pair of points in  $S$ , every point on the straight line segment that joins the pair of points also belongs to  $S$ . The hexagons may overlap.

(Josip Pupic, Borna Vukorepa)

**Solution.** It is possible to make such arrangement.

**0 points.**

We will stack hexagons in a triangular pattern shown below, where the first row has one hexagon, second row has two and so on. The pattern on the picture is a triangle with four rows.

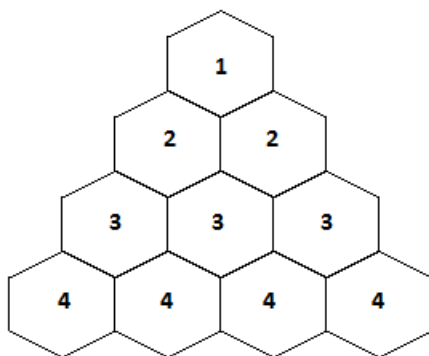

**3 points.**

Such triangle with  $n$  rows has an area of  $\frac{n(n+1)}{2}$  since that is the total number of hexagons used for that pattern.

**1 point.**

Setting  $n = 1950$  gives us a triangle with 1950 rows. That figure has an area of 1902225 and the same number of hexagons is used. The only problem is that it is not convex.

**1 point.**

We can use the remaining hexagons to fix the non-convex parts of the figure, as shown below.

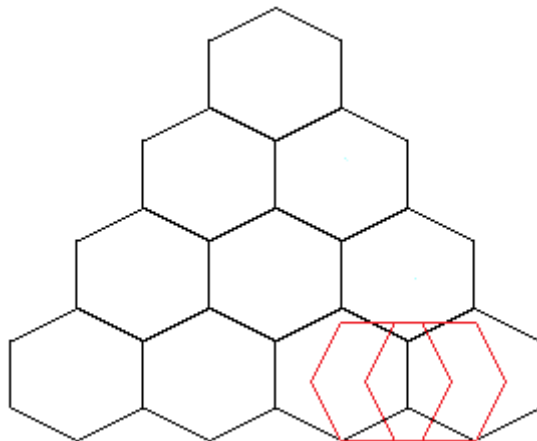

**3 points.**

Every non-convex part can be fixed with two hexagons, so in total we will need  $1949 \cdot 3 \cdot 2 = 11694$  hexagons to make the figure convex. This is because there are 1949 non-convex parts on every side of our triangular pattern. Obviously, this is much less hexagons than we have remaining. The resulting figure is now convex, so this completes the proof.

**2 points.**

**Notes on marking:**

- Sketches of stacking the hexagons in any pattern will not be worth any points if there is no work done on them.

- No points are awarded for the claim that the construction is possible.
- There are many patterns for stacking the hexagons which can give the correct solution. Each of them should be marked the same way as this one.
- Work on patterns which can't produce the desired area will not be worth any points.

**Problem 3.** Let  $ABC$  be an acute triangle. Denote by  $H$  and  $M$  the orthocenter of  $ABC$  and the midpoint of side  $BC$ , respectively. Let  $Y$  be a point on  $AC$  such that  $YH$  is perpendicular to  $MH$  and let  $Q$  be a point on  $BH$  such that  $QA$  is perpendicular to  $AM$ . Let  $J$  be the second point of intersection of  $MQ$  and the circle with diameter  $MY$ . Prove that  $HJ$  is perpendicular to  $AM$ .

(Steve Dinh)

**Solution.** We present the following diagram:

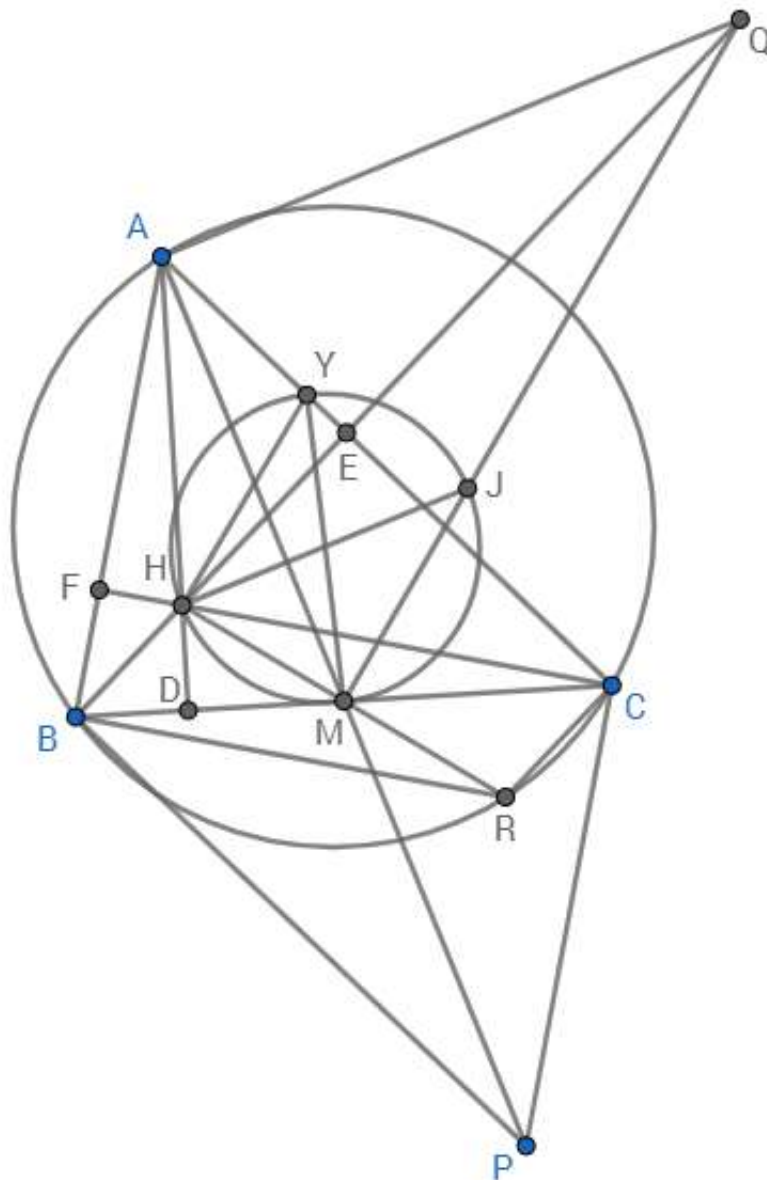

0 points.

Since  $\angle MHY = 90^\circ$ ,  $Y$  lies on the circle with diameter  $MY$ , so the quadrilateral  $HMJY$  is cyclic.

1 point.

It follows that  $\angle HJM = \angle HYM$ . Since  $QA \perp AM$ ,

$$HJ \perp AM \iff HJ \parallel QA \iff \angle HJM = \angle AQM \iff \angle HYM = \angle AQM.$$

Since  $\angle YHM = \angle QAM = 90^\circ$ , the latter is equivalent to  $\triangle AQM \sim \triangle HYM$ .

1 point.

Now we have two different approaches to finish the solution:

**First Approach (Synthetic).** Let  $P, R$  be the reflections of  $A, H$  in  $M$ , respectively. Then since  $\angle YHM = \angle QAM = 90^\circ$ , i.e.  $\angle YHR = \angle QAP = 90^\circ$ ,

$$\triangle AQM \sim \triangle HYM \iff \frac{AQ}{HY} = \frac{AM}{HM} \iff \frac{AQ}{HY} = \frac{\frac{1}{2}AP}{\frac{1}{2}HR} \iff \frac{AQ}{HY} = \frac{AP}{HR} \iff \triangle AQP \sim \triangle HYR \iff \angle QPA = \angle YRH.$$

**3 points.**

Since  $M$  is the midpoint of  $BC$ , the quadrilaterals  $ABPC$  and  $HBRC$  are parallelograms.

**1 point.**

Since  $CR \parallel HB$  and  $HB \perp AC$ , it follows that  $\angle ACR = 90^\circ$ . Hence  $\angle YCR = \angle RHY = 90^\circ$ , so the quadrilateral  $YHRC$  is cyclic.

**1 point.**

It follows that  $\angle YRH = \angle YCH = \angle ACF = 90^\circ - \angle BAC$ .

**1 point.**

Since  $BP \parallel AC$  and  $AC \perp BQ$ , we have  $PBQ = 90^\circ$ . Hence  $\angle PBQ = \angle PAQ = 90^\circ$ , so the quadrilateral  $ABPQ$  is cyclic.

**1 point.**

It follows that  $\angle QPA = \angle QBA = \angle EBA = 90^\circ - \angle BAC$ .

**1 point.**

Finally, we conclude that  $\angle YRH = \angle QPA$ , as desired.

**Second Approach (Trigonometric).** We will show that  $\triangle AQM \sim \triangle HYM$  by proving that

$$\frac{AQ}{AM} = \frac{HY}{HM}.$$

To begin with, let  $a = BC, b = CA, c = AB$  and  $\alpha = \angle BAC, \beta = \angle CBA, \gamma = \angle ACB$ .

From right-angled  $\triangle AEQ$  we get  $AQ = \frac{AE}{\cos \angle EAQ} = \frac{AE}{\sin \angle MAC}$ .

Then from right-angled  $\triangle ABE$  we obtain  $AE = AB \cos \angle BAE = c \cos \alpha$ , so  $AQ = \frac{c \cos \alpha}{\sin \angle MAC}$ , i.e.  $\frac{AQ}{AM} = \frac{c \cos \alpha}{AM \sin \angle MAC}$ .

By the sine law applied to  $\triangle AMC$ , we obtain  $\frac{AM}{\sin \angle ACM} = \frac{MC}{\sin \angle MAC}$ , i.e.  $AM \sin \angle MAC = \frac{c}{2} \sin \gamma$ .

It follows that  $\frac{AQ}{AM} = \frac{c \cos \alpha}{\frac{c}{2} \sin \gamma} = \frac{2 \cos \alpha}{\sin \gamma} = \frac{2 \cos \alpha}{\frac{a}{c} \sin \alpha} = \frac{2 \cos \alpha}{\sin \alpha} = 2 \cot \alpha$ , where we used the sine law applied to  $\triangle ABC$ .

**4 points.**

To conclude, note that  $\triangle AHY \sim \triangle BMH$  since  $\angle HAY = \angle MBH = 90^\circ - \gamma$  and  $\angle YHA = \angle HMB$  (angles with perpendicular rays). Then  $\frac{HY}{HM} = \frac{AH}{BM} = 2 \cot \alpha$ , so we are done.

**4 points.**

**Notes on marking:**

- The points from different approaches are not additive, a student should be awarded the maximum of points obtained from one of them.

**Problem 4.** The real numbers  $x, y, z$  satisfy  $x^2 + y^2 + z^2 = 3$ . Prove the inequality

$$x^3 - (y^2 + yz + z^2)x + y^2z + yz^2 \leq 3\sqrt{3}$$

and find all triples  $(x, y, z)$  for which equality holds.

(Miroslav Marinov)

**Solution.** First let us notice the factorization of the left-hand side

$$x^3 - (y^2 + yz + z^2)x + y^2z + yz^2 = (x - y)(x - z)(x + y + z)$$

**2 points.**

Now we get the following inequalities

$$\begin{aligned} & (x^3 - (y^2 + yz + z^2)x + y^2z + yz^2)^{\frac{2}{3}} \\ &= \sqrt[3]{(x - y)^2(x - z)^2(x + y + z)^2} \end{aligned}$$

**1 point.**

$$\stackrel{G-A}{\leq} \frac{1}{3}((x - y)^2 + (x - z)^2 + (x + y + z)^2)$$

**3 points.**

$$= \frac{1}{3}(3x^2 + 2y^2 + 2z^2 + 2yz)$$

$$= \frac{1}{3}(6 + x^2 + 2yz)$$

$$\stackrel{G-A}{\leq} \frac{1}{3}(6 + x^2 + y^2 + z^2)$$

**1 point.**

$$= \frac{9}{3} = 3$$

from where we get the required inequality by raising to the power of  $\frac{3}{2}$ .

In the case of equality, expressions  $|x - y|$ ,  $|x - z|$  and  $|x + y + z|$  are all equal to  $\sqrt{3}$  which we conclude from the first G-A inequality. From the case of equality in the second G-A inequality we conclude  $y = z$ . Now from  $|x - y| = \sqrt{3}$  we get 2 cases:

- $x - y = \sqrt{3} \Rightarrow |3y + \sqrt{3}| = \sqrt{3}$  from where we get  $y = 0$  or  $y = -\frac{2\sqrt{3}}{3}$  which gives us potential solutions  $(\sqrt{3}, 0, 0)$  and  $(\frac{\sqrt{3}}{3}, -\frac{2\sqrt{3}}{3}, -\frac{2\sqrt{3}}{3})$ . By checking only  $(\sqrt{3}, 0, 0)$  remains.
- $x - y = -\sqrt{3} \Rightarrow |3y - \sqrt{3}| = \sqrt{3}$  from where we get  $y = 0$  or  $y = \frac{2\sqrt{3}}{3}$  which gives us potential solutions  $(-\sqrt{3}, 0, 0)$  and  $(-\frac{\sqrt{3}}{3}, \frac{2\sqrt{3}}{3}, \frac{2\sqrt{3}}{3})$ . By checking only  $(-\frac{\sqrt{3}}{3}, \frac{2\sqrt{3}}{3}, \frac{2\sqrt{3}}{3})$  remains.

**3 points.**

**Notes on marking:**

- Factorization from the beginning can be spotted because  $y$  and  $z$  are obviously roots of the polynomial equation  $x^3 - (y^2 + yz + z^2)x + y^2z + yz^2 = 0$  in the variable  $x$ .
- 1 point is to be deducted if potential solutions aren't checked out i.e. either  $(\frac{\sqrt{3}}{3}, -\frac{2\sqrt{3}}{3}, -\frac{2\sqrt{3}}{3})$  or  $(-\sqrt{3}, 0, 0)$  is stated as solutions for the case of equality and.
- Proving the inequality is worth **7 points** while the rest is worth **3 points** non-dependently on the way in which it was proved.

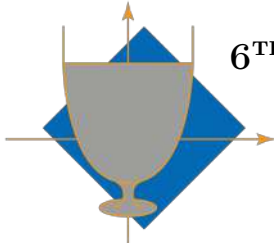

6<sup>TH</sup> EUROPEAN MATHEMATICAL CUP  
9<sup>th</sup> December 2017–17<sup>th</sup> December 2017  
Senior Category



**Problem 1.** Find all functions  $f : \mathbb{N} \rightarrow \mathbb{N}$  such that the inequality

$$f(x) + yf(f(x)) \leq x(1 + f(y))$$

holds for all positive integers  $x, y$ .

(Adrian Beker)

**Problem 2.** A friendly football match lasts 90 minutes. In this problem, we consider one of the teams, coached by Sir Alex, which plays with 11 players at all times.

- Sir Alex wants for each of his players to play the same integer number of minutes, but each player has to play less than 60 minutes in total. What is the minimum number of players required?
- For the number of players found in a), what is the minimum number of substitutions required, so that each player plays the same number of minutes?

*Remark:* Substitutions can only take place after a positive integer number of minutes, and players who have come off earlier can return to the game as many times as needed. There is no limit to the number of substitutions allowed.

(Athanasios Kontogeorgis, Demetres Christofides)

**Problem 3.** Let  $ABC$  be a scalene triangle and let its incircle touch sides  $BC, CA$  and  $AB$  at points  $D, E$  and  $F$  respectively. Let line  $AD$  intersect this incircle at point  $X$ . Point  $M$  is chosen on the line  $FX$  so that the quadrilateral  $AFEM$  is cyclic. Let lines  $AM$  and  $DE$  intersect at point  $L$  and let  $Q$  be the midpoint of segment  $AE$ . Point  $T$  is given on the line  $LQ$  such that the quadrilateral  $ALDT$  is cyclic. Let  $S$  be a point such that the quadrilateral  $TFSA$  is a parallelogram, and let  $N$  be the second point of intersection of the circumcircle of triangle  $ASX$  and the line  $TS$ . Prove that the circumcircles of triangles  $TAN$  and  $LSA$  are tangent to each other.

(Andrej Ilievski)

**Problem 4.** Find all polynomials  $P$  with integer coefficients such that  $P(0) \neq 0$  and

$$P^n(m) \cdot P^m(n)$$

is a square of an integer for all nonnegative integers  $n, m$ .

*Remark:* For a nonnegative integer  $k$  and an integer  $n$ ,  $P^k(n)$  is defined as follows:  $P^k(n) = n$  if  $k = 0$  and  $P^k(n) = P(P^{k-1}(n))$  if  $k > 0$ .

(Adrian Beker)

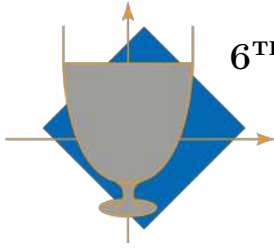

**6<sup>TH</sup> EUROPEAN MATHEMATICAL CUP**  
9<sup>th</sup> December 2017–23<sup>rd</sup> December 2017  
Senior Category



## Problems and Solutions

**Problem 1.** Find all functions  $f : \mathbb{N} \rightarrow \mathbb{N}$  such that the inequality

$$f(x) + yf(f(x)) \leq x(1 + f(y))$$

holds for all positive integers  $x, y$ .

*(Adrian Beker)*

**Solution.** We claim that  $f(x) = x$  is the only function that satisfies the inequality for all positive integers  $x, y$ .

We can see that it is indeed the solution because  $x + yx = x(1 + y)$ .

Setting  $x = 1$  and  $y = 1$ , we obtain:

$$f(1) + f(f(1)) \leq 1 + f(1),$$

which implies  $f(f(1)) \leq 1$ , so  $f(f(1)) = 1$  because it must be a positive integer.

**1 point.**

Setting  $x = 1$  and  $y = f(1)$ , we obtain:

$$f(1) + f(1) \leq 1 + f(1),$$

which similarly implies  $f(1) = 1$ .

**3 points.**

Now, setting  $x = 1$  gives:

$$1 + y \leq 1 + f(y),$$

so  $f(y) \geq y$  for all positive integers  $y$ .

Setting  $y = 1$  and using the previous fact, we write:

$$f(x) + f(f(x)) \leq 2x \leq 2f(x) = f(x) + f(x) \leq f(x) + f(f(x)),$$

so equality holds on each step. In particular,  $f(x) = x$  for every positive integer  $x$ .

**6 points.**

### Notes on marking:

- Checking that  $f(x) = x$  satisfies the inequality is worth **0 points**. If a student shows that a solution, if it exists, must be the identity function ("solves the problem"), but fails to show that the identity function is indeed the solution, he or she shall be deducted **1 point**. A sentence saying something along the lines of "it is trivial to show that the identity function satisfies the inequality", due to the sentence being true, shall not be deducted the point.

**Problem 2.** A friendly football match lasts 90 minutes. In this problem, we consider one of the teams, coached by Sir Alex, which plays with 11 players at all times.

- a) Sir Alex wants for each of his players to play the same integer number of minutes, but each player has to play less than 60 minutes in total. What is the minimum number of players required?
- b) For the number of players found in a), what is the minimum number of substitutions required, so that each player plays the same number of minutes?

*Remark:* Substitutions can only take place after a positive integer number of minutes, and players who have come off earlier can return to the game as many times as needed. There is no limit to the number of substitutions allowed.

*(Athanasios Kontogeorgis, Demetres Christofides)*

**Solution.** a) Since exactly 11 players play at all times, the total number of minutes played by all of the players combined is  $11 \cdot 90 = 990$ . Let  $n$  be the number of Sir Alex's players that have participated in the match and let  $k$  be the number of minutes which each of them spent playing, with  $k < 60$  and  $k \in \mathbb{Z}$ . Now the equality  $nk = 990$  holds.

**1 point.**

From that fact combined with  $k < 60$  we get  $n \geq 17$  and  $n|990$  as well. Finally, it is easy to conclude that the minimal such  $n$  is 18.

**1 point.**

Construction.

**1 point.**

- b) We can formulate the problem by using graphs. Let us construct a graph with 18 vertices that represent the players. Two vertices are connected by an edge if one of the corresponding players substituted the other.

**1 point.**

Suppose that less than 17 substitutions were made. Then the graph isn't connected and the smallest connected component consists of  $k \leq 9$  players among which all of their substitutions were made.

**1 point.**

Let us suppose that exactly  $r$  of them are on the pitch at all times. It is easy to determine that each of the 18 players will play exactly 55 minutes. So the players from the smallest connected component will spend the combined total of  $55k$  minutes playing. But, from the same conclusion as earlier, we get the equality  $55k = 90r$ . It follows that  $11|r$  which implies  $r > 9$  and so we reach a contradiction.  $\Rightarrow$  The graph is connected and at least 17 substitutions are required.

**3 points.**

The following table shows a match in which each of the 18 players played 55 minutes and exactly 17 substitutions were made (the shaded regions correspond to the time intervals played by each player).

		Time																		
		0'	5'	10'	15'	20'	25'	30'	35'	40'	45'	50'	55'	60'	65'	70'	75'	80'	85'	90'
Players	1																			
	2																			
	3																			
	4																			
	5																			
	6																			
	7																			
	8																			
	9																			
	10																			
	11																			
	12																			
	13																			
	14																			
	15																			
	16																			
	17																			
	18																			

**2 points.**

**Notes on marking:**

- An example for construction in **a)** is the construction from **b)** but there are far easier examples than that and any correct one can bring that 1 point. If a student didn't make the construction in **a)** but finds one in **b)**, he or she shall be awarded both the 1 point from **a)** and 2 points from **b)** for it but if the student doesn't write a construction neither in **a)** nor **b)**, all 3 mentioned points are to be deducted.
- There can be an argument made for **b)** without observing graphs and has to be evaluated accordingly. If a student reaches the conclusion equivalent to the smallest connected component, **2 points** have to be given, one for that conclusion and one that is intended for observing the graph in the official solution.

**Problem 3.** Let  $ABC$  be a scalene triangle and let its incircle touch sides  $BC, CA$  and  $AB$  at points  $D, E$  and  $F$  respectively. Let line  $AD$  intersect this incircle at point  $X$ . Point  $M$  is chosen on the line  $FX$  so that the quadrilateral  $AFEM$  is cyclic. Let lines  $AM$  and  $DE$  intersect at point  $L$  and let  $Q$  be the midpoint of segment  $AE$ . Point  $T$  is given on the line  $LQ$  such that the quadrilateral  $ALDT$  is cyclic. Let  $S$  be a point such that the quadrilateral  $TFSA$  is a parallelogram, and let  $N$  be the second point of intersection of the circumcircle of triangle  $ASX$  and the line  $TS$ . Prove that the circumcircles of triangles  $TAN$  and  $LSA$  are tangent to each other.

(Andrej Ilievski)

**Solution.** We present the following diagram:

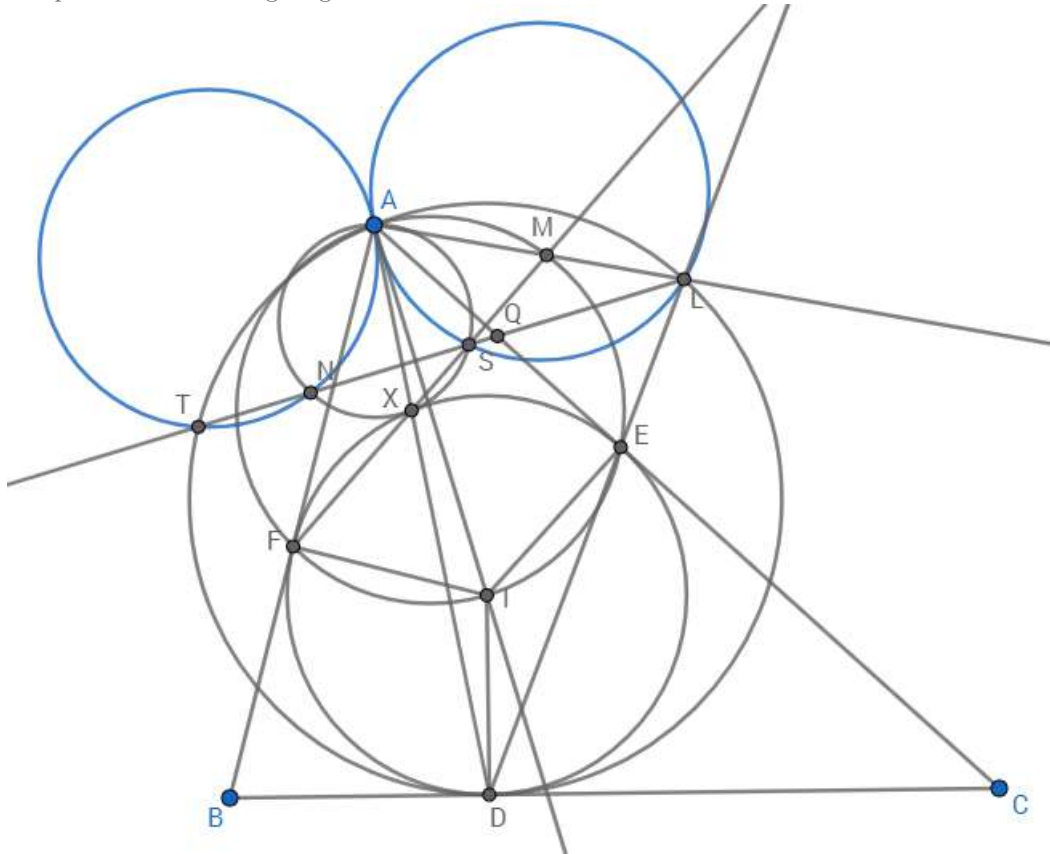

0 points.

Let  $P$  be the midpoint of segment  $AF$  and let  $R$  be the second intersection of  $EX$  and the circumcircle of  $\triangle AFE$ . Let  $K$  denote the intersection of lines  $AR$  and  $DF$ .

By the tangent-chord theorem, we have  $\angle EDX = \angle AEX$ . Since  $DEXF$  is cyclic, we have  $\angle EDX = \angle EFX = \angle EFM$ . Since  $AFEM$  is cyclic, we have  $\angle EFM = \angle EAM = \angle EAL$ . Hence,  $\angle AEX = \angle EAL$ , so  $AL \parallel EX$ , and analogously  $AK \parallel FX$ . Furthermore, we have  $\angle EDX = \angle EAL$ , i.e.  $\angle EDA = \angle EAL$ , so by the converse of the tangent-chord theorem,  $LA$  is tangent to the circumcircle of  $\triangle AED$ .

2 points.

By power of a point, we have  $LA^2 = LE \cdot LD$ . If we denote the radical axis of the incircle of  $\triangle ABC$  and the degenerate circle  $A$  by  $\ell$ , this means that  $L$  lies on  $\ell$ . Analogously,  $K$  lies on  $\ell$ .

1 point.

Now, since  $QA^2 = QE^2$ ,  $PA^2 = PF^2$  and  $QE, PF$  are tangents to the incircle of  $\triangle ABC$ , it follows that  $P, Q$  both lie on  $\ell$ . Since  $PQ$  is the midline of  $\triangle AEF$ , we have  $\ell \parallel EF$ .

1 point.

Since  $AL \parallel EX$ ,  $AK \parallel FX$  and  $XFDE$  is cyclic, it follows that  $AKDL$  is also cyclic. Hence,  $K$  is the second intersection of  $LQ$  and the circumcircle of  $\triangle ALD$ , so we must have  $K \equiv T$ , i.e.  $T, F, D$  are collinear.

1 point.

Since  $TFSA$  is a parallelogram,  $TS$  bisects the segment  $AF$ , i.e.  $T, P, S$  are collinear, which means that  $S$  lies on  $\ell$ . Moreover, since  $AT \parallel FS$  and  $AT \parallel FX$ , it follows that  $F, X, S$  are collinear.

**1 point.**

Then since  $ANXS$  is cyclic,  $\angle NAX = \angle NSX$ . Since  $NS \parallel FE$ ,  $\angle NSX = \angle EFX$ . Since  $ALDT$  and  $XEDF$  are both cyclic, we have  $\angle NTA = \angle LTA = \angle LDA = \angle EDX = \angle EFX$ , so  $\angle NAX = \angle NTA$ . Hence, by the converse of the tangent-chord theorem,  $AX$  is tangent to the circumcircle of  $\triangle TAN$ .

**2 points.**

Finally, since  $AS \parallel TF$ , i.e.  $AS \parallel FD$ , we have  $\angle XAS = \angle XDF$ . Again, using the cyclicity of  $ALDT$  and  $XEDF$ , we have  $\angle ALS = \angle ALT = \angle ADT = \angle XDF$ , so  $\angle XAS = \angle ALS$ . Hence, by the converse of the tangent-chord theorem,  $AX$  is tangent to the circumcircle of  $\triangle LSA$ .

**2 points.**

Since  $AX$  is the common tangent of the circumcircles of triangles  $TAN$  and  $LSA$ , it follows that they are tangent to each other at  $A$ , as desired.

**Notes on marking:**

- There are many different ways to finish the solution once the collinearities of  $T, F, D$  and  $F, X, S$  are established. One can, for example, show that  $E, X, N$  are also collinear by noting that  $\angle XNS = \angle XAS = \angle XDF = \angle XEF$  and using the fact that  $SN \parallel FE$ , for which a student should be awarded **2 points**. Then one can establish the result by introducing the tangent to the circumcircle of  $\triangle TAN$  at  $A$  and using the tangent-chord theorem and its converse together with the fact that  $\angle NTA + \angle ALS = \angle NAS$  holds. This part is worth **2 points**. However, points from different approaches are not additive, a student should be awarded the maximum of points obtained from one of them.

**Problem 4.** Find all polynomials  $P$  with integer coefficients such that  $P(0) \neq 0$  and

$$P^n(m) \cdot P^m(n)$$

is a square of an integer for all nonnegative integers  $n, m$ .

*Remark:* For a nonnegative integer  $k$  and an integer  $n$ ,  $P^k(n)$  is defined as follows:  $P^k(n) = n$  if  $k = 0$  and  $P^k(n) = P(P^{k-1}(n))$  if  $k > 0$ .

(Adrian Beker)

**Solution.** Let  $Q(n, m)$  denote the assertion " $P^n(m) \cdot P^m(n)$  is a square of an integer".

We claim that  $P(x) = x + 1$  is the unique polynomial with integer coefficients such that  $P(0) \neq 0$  and  $Q(n, m)$  is true for all  $n, m \in \mathbb{N}_0$ .

First we check that this polynomial indeed satisfies the conditions. An easy induction on  $k$  shows that  $P^k(n) = n + k$  for all  $n, k \in \mathbb{N}_0$ . Then  $P^n(m) \cdot P^m(n) = (m + n)^2$ , which is clearly a square of an integer, hence  $Q(n, m)$  is true for all  $n, m \in \mathbb{N}_0$ .

1 point.

Now we show that  $P(x) = x + 1$  is the only polynomial satisfying all the conditions.

Consider the sequence  $(a_n)_{n \geq 0}$  defined by  $a_n = P^n(0)$  for all  $n \geq 0$ . Then  $Q(n, 0)$  implies that  $n \cdot a_n$  is a square of an integer for all  $n \in \mathbb{N}_0$ .

1 point.

**Lemma 1.** For all sufficiently large primes  $p$ , the sequence  $(a_n)$  modulo  $p$  is periodic with minimal period of length exactly  $p$ . In particular, for all sufficiently large primes  $p$ ,  $P$  is bijective when considered modulo  $p$ .

*Proof:* Fix a prime  $p > \max\{|P(0)|, 2\}$ . Let  $t$  be the smallest positive integer for which there exists a nonnegative integer  $s < t$  such that  $a_s \equiv a_t \pmod{p}$ , such a  $t$  exists by the Pigeonhole principle. Then the sequence  $(a_n)$  modulo  $p$  is eventually periodic with minimal period  $a_s, \dots, a_{t-1}$ .

1 point.

Suppose that  $t - s < p$  holds, i.e. the length of the period is less than  $p$ . Note that there exists  $r \in \{s, \dots, t - 1\}$  such that  $a_r \not\equiv 0 \pmod{p}$  since otherwise we would have  $P(0) \equiv 0 \pmod{p}$ . Now let  $n$  be an arbitrary nonnegative integer. Then take a positive integer  $k$  such that  $n + kp \geq s$  and  $n + kp \equiv r \pmod{t - s}$ , such a  $k$  exists since  $p$  and  $t - s$  are relatively prime.

We know that  $(n + kp) \cdot a_{n+kp}$  is a quadratic residue modulo  $p$ , i.e.  $n \cdot a_r$  is a quadratic residue modulo  $p$  since  $a_{n+kp} \equiv a_r \pmod{p}$  and  $n + kp \equiv n \pmod{p}$ . But this is impossible since  $n \cdot a_r$  attains all residues modulo  $p$  (recall that  $a_r \not\equiv 0 \pmod{p}$ ), and we know there exists a quadratic nonresidue modulo  $p$  since  $p > 2$ .

Finally, we conclude that  $t - s = p$  must hold, i.e. the length of the minimal period is  $p$ . In particular,  $P$  is surjective and hence bijective when considered modulo  $p$ .

2 points.

*Alternative proof:* Again, fix a prime  $p > |P(0)|$ . Since  $p \cdot a_p$  is a perfect square,  $a_p$  must be divisible by  $p$ . It follows that for all  $n \geq 0$ ,  $a_{n+p} = P^n(a_p) \equiv P^n(0) \equiv a_n \pmod{p}$ , hence  $(a_n)$  modulo  $p$  is periodic with period of length  $p$ .

1 point.

Now suppose there exist  $i, j \in \{0, 1, \dots, p - 1\}$  with  $i < j$  and  $a_i \equiv a_j \pmod{p}$ . If we let  $l = j - i$ , then for each  $n \geq i$  we have  $a_{n+l} = P^{n-j+l}(a_j) \equiv P^{n-i}(a_i) \equiv a_n \pmod{p}$ . Then it immediately follows inductively that  $a_n \equiv a_{n+kl} \pmod{p}$  for all  $k \in \mathbb{N}_0$  and similarly  $a_n \equiv a_{n+mp} \pmod{p}$  for all  $m \in \mathbb{N}_0$ . Since  $p$  and  $l$  are relatively prime, there exist  $k, m \in \mathbb{N}_0$  such that  $kl - mp = 1$ , so we have  $a_n \equiv a_{n+1} \pmod{p}$ . It follows that the sequence is eventually constant and thus equal to 0 modulo  $p$ , which is a contradiction. Hence, the length of the minimal period is indeed  $p$  and we conclude similarly as in the first proof.

2 points.

**Lemma 2.** The degree of  $P$  is at most 1.

*Proof:* Assume the contrary and consider the polynomial  $Q(x) = P(x + 1) - P(x)$ . Then  $Q$  is a polynomial with integer coefficients and  $\deg Q = \deg P - 1 \geq 1$ , so  $Q$  is nonconstant. A well-known fact due to Schur implies that there are infinitely many primes that divide  $Q(n)$  for some integer  $n$ . So there are infinitely many primes  $p$  such that  $P$  is not bijective modulo  $p$ , contradicting the result of Lemma 1. Hence, the lemma is proved.

3 points.

By Lemma 2, we can write  $P(x) = ax + b$  for some  $a, b \in \mathbb{Z}$ .  $Q(1, 0)$  implies that  $b$  is a perfect square, so  $b$  is a positive integer since  $P(0) \neq 0$ .

An easy induction shows that  $P^k(0) = b(1 + a + \dots + a^{k-1})$  for all  $k \in \mathbb{N}$ .  $Q(p, 0)$  implies that  $pb(1 + a + \dots + a^{p-1})$  is a perfect square, i.e.  $p(1 + a + \dots + a^{p-1})$  is a perfect square for all primes  $p$ . So  $1 + a + \dots + a^{p-1}$  must be divisible by  $p$ , but then  $(1 + a + \dots + a^{p-1})(a - 1) = a^p - 1$  is also divisible by  $p$ . By Fermat's little theorem, we know that  $a^p - 1 \equiv a - 1 \pmod{p}$ , hence  $p$  divides  $a - 1$  for all primes  $p$ , so we must have  $a = 1$ , i.e.  $P(x) = x + b$ .

**1 point.**

Finally,  $Q(1, 4)$  implies that  $4b^2 + 17b + 4$  is a perfect square, but since  $(2b + 2)^2 < 4b^2 + 17b + 4 < (2b + 5)^2$ ,  $4b^2 + 17b + 4$  must be of the form  $(2b + k)^2$  for some  $k \in \{3, 4\}$ . It is easily checked that  $b = 1$  is the only possibility, leaving  $P(x) = x + 1$  as the only solution.

**1 point.**

**Notes on marking:**

- The points from different proofs of Lemma 1 are not additive, a student should be awarded the maximum of points obtained from one of them.

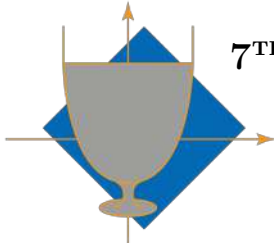

**7<sup>TH</sup> EUROPEAN MATHEMATICAL CUP**  
*8<sup>th</sup> December 2018 - 16<sup>th</sup> December 2018*  
Junior Category



**Problem 1.** Let  $a, b, c$  be non-zero real numbers such that

$$a^2 + b + c = \frac{1}{a},$$

$$b^2 + c + a = \frac{1}{b},$$

$$c^2 + a + b = \frac{1}{c}.$$

Prove that at least two of  $a, b, c$  are equal.

*(Daniel Paleka)*

**Problem 2.** Find all pairs  $(x, y)$  of positive integers such that

$$xy \mid x^2 + 2y - 1.$$

*(Ivan Novak)*

**Problem 3.** Let  $ABC$  be an acute triangle with  $|AB| < |AC|$  and orthocenter  $H$ . The circle with center  $A$  and radius  $|AC|$  intersects the circumcircle of  $\triangle ABC$  at point  $D$  and the circle with center  $A$  and radius  $|AB|$  intersects the segment  $\overline{AD}$  at point  $K$ . The line through  $K$  parallel to  $CD$  intersects  $BC$  at the point  $L$ . If  $M$  is the midpoint of  $\overline{BC}$  and  $N$  is the foot of the perpendicular from  $H$  to  $AL$ , prove that the line  $MN$  bisects the segment  $\overline{AH}$ .

*(Miroslav Marinov)*

**Problem 4.** Let  $n$  be a positive integer. Ana and Banana are playing the following game:

First, Ana arranges  $2n$  cups in a row on a table, each facing upside-down. She then places a ball under a cup and makes a hole in the table under some other cup. Banana then gives a finite sequence of commands to Ana, where each command consists of swapping two adjacent cups in the row.

Her goal is to achieve that the ball has fallen into the hole during the game. Assuming Banana has no information about the position of the hole and the position of the ball at any point, what is the smallest number of commands she has to give in order to achieve her goal?

*(Adrian Beker)*

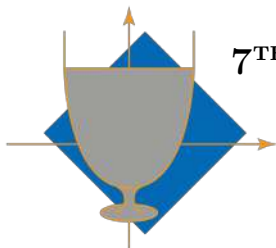

**7<sup>TH</sup> EUROPEAN MATHEMATICAL CUP**  
8<sup>th</sup> December 2018 - 16<sup>th</sup> December 2018  
Junior Category



## Problems and Solutions

**Problem 1.** Let  $a, b, c$  be non-zero real numbers such that

$$\begin{aligned}a^2 + b + c &= \frac{1}{a}, \\b^2 + c + a &= \frac{1}{b}, \\c^2 + a + b &= \frac{1}{c}.\end{aligned}$$

Prove that at least two of  $a, b, c$  are equal.

*(Daniel Paleka)*

**First Solution.** Let's assume the opposite, i.e.  $a, b$  and  $c$  are pairwise non-equal. By subtracting the second equality from the first one, we obtain

$$\begin{aligned}(a^2 + b + c) - (b^2 + c + a) &= \frac{1}{a} - \frac{1}{b} \\(a^2 - b^2) + (b - a) &= \frac{b - a}{ab} \\(a - b)(a + b) - (a - b) + \frac{a - b}{ab} &= 0 \\(a - b)\left(a + b - 1 + \frac{1}{ab}\right) &= 0\end{aligned}$$

**1 point.**

Since  $a \neq b$  we may conclude

$$a + b - 1 + \frac{1}{ab} = 0 \tag{1}$$

**1 point.**

Similarly, subtracting the third equality from the second one, combined with  $b \neq c$ , gives us

$$b + c - 1 + \frac{1}{bc} = 0 \tag{2}$$

**1 point.**

Expressions on the left side in (1) and (2) are both equal to 0 which specifically implies

$$\begin{aligned}a + b - 1 + \frac{1}{ab} &= b + c - 1 + \frac{1}{bc} \\(a - c) + \frac{1}{b} \cdot \left(\frac{1}{a} - \frac{1}{c}\right) &= 0 \\(a - c) + \frac{1}{b} \cdot \frac{c - a}{ac} &= 0 \\(a - c)\left(1 - \frac{1}{b} \cdot \frac{1}{ac}\right) &= 0 \\1 - \frac{1}{abc} &= 0 \\abc &= 1\end{aligned}$$

**2 points.**

Inserting that back into (1) results with

$$0 = a + b - 1 + \frac{1}{ab} = a + b - 1 + \frac{abc}{ab} = a + b - 1 + c$$

$$\Rightarrow b + c = 1 - a \tag{3}$$

**2 points.**

Finally, combining (3) with the first of the 3 given equations results with

$$\begin{aligned} a^2 + b + c &= \frac{1}{a} \\ a^2 + 1 - a &= \frac{1}{a} \\ (a^2 - a) + \left(1 - \frac{1}{a}\right) &= 0 \\ a(a - 1) + \frac{a - 1}{a} &= 0 \\ (a - 1) \left(a + \frac{1}{a}\right) &= 0 \\ (a - 1) \cdot \frac{a^2 + 1}{a} &= 0 \end{aligned}$$

Because of  $a^2 + 1 > 0$  we obtain  $a - 1 = 0$ , i.e.  $a = 1$ .

**2 points.**

Analogously we also find  $b = c = 1$  which is a contradiction with the assumption so we conclude that at least two of  $a, b, c$  are equal.

**1 point.**

**Second Solution.** Let's assume the contrary, i.e.  $a$ ,  $b$  and  $c$  are pairwise different. After multiplying the first equation with  $a$ , the second with  $b$ , and the third with  $c$ , we get:

$$a^3 + ab + ac = b^3 + bc + ba = c^3 + ca + cb = 1.$$

**0 points.**

In particular, the first two expressions are equal. Subtracting them and factorizing leads to:

$$\begin{aligned} a^3 - b^3 + ac - bc &= 0 \\ (a - b)(a^2 + ab + b^2 + c) &= 0 \end{aligned}$$

**1 point.**

Since  $a \neq b$  we may conclude:

$$a^2 + ab + b^2 + c = 0$$

**1 point.**

Similarly, we can get the same thing for  $b$  and  $c$ :

$$b^2 + bc + c^2 + a = 0$$

**1 point.**

Subtracting these two equations yields:

$$\begin{aligned} a^2 - c^2 + ab - bc + c - a &= 0 \\ (a - c)(a + c + b - 1) &= 0 \end{aligned}$$

**2 points.**

Because  $a \neq c$ , we obtain:

$$a + b + c = 1$$

**2 points.**

Now we proceed to arrive to a contradiction in the same way as in the previous solution.

**3 points.**

**Notes on marking:**

- After obtaining  $a = 1$ , we may use that fact in (3) to conclude  $b + c = 0$ , i.e.  $c = -b$ . That gives us

$$1 = abc = 1 \cdot b \cdot (-b) = -b^2$$

which isn't satisfied for any  $b \in \mathbb{R}$ . Again we reach contradiction with the assumption and conclude that at least two of  $a, b, c$  are equal. This part of the solution should be awarded with **1 point**.

**Problem 2.** Find all pairs  $(x, y)$  of positive integers such that

$$xy \mid x^2 + 2y - 1.$$

(Ivan Novak)

**First Solution.** Notice that the condition implies

$$x \mid 2y - 1.$$

1 point.

This implies that there exists a positive integer  $k$  such that  $kx = 2y - 1$ , so  $y = \frac{kx+1}{2}$ .

1 point.

Returning to the starting assertion, we get that

$$\frac{x(kx+1)}{2} \mid x^2 + kx \implies kx+1 \mid 2(k+x).$$

2 points.

For all positive integers  $k, x$ , the following inequality is satisfied, with equality if and only if  $k = 1$  or  $x = 1$ :

$$\frac{2(k+x)}{kx+1} \leq 2 \iff 2(k-1)(x-1) \geq 0.$$

2 points.

So as  $\frac{2(k+x)}{kx+1} \in \mathbb{N}$ , then we conclude that  $\frac{2(k+x)}{kx+1} \in \{1, 2\}$ .

1 point.

We now have two possible cases.

1.  $k+x = kx+1$ . In this case,  $k=1$  or  $x=1$ .
  - (a) If  $x=1$ , then  $y$  can be any positive integer.
  - (b) If  $k=1$ , then  $x=2y-1$ , where  $y$  is any positive integer.

1 point.

2.  $2k+2x = kx+1$ . Then  $2x-1 = k(x-2) \implies x-2 \mid 2x-1 \implies x-2 \mid 3$ . This has only two solutions, both of which are true by an easy check:  $x=3, k=5, y=8$  or  $x=5, k=3, y=8$ .

2 points.

Therefore, the set of solutions is

$$(x, y) \in \{(1, t), (2t-1, t), (3, 8), (5, 8) \mid t \in \mathbb{N}\}$$

**Second Solution.** Let  $(x, y)$  be a solution, and let  $\frac{x^2+2y-1}{xy} = g$ . This equation is equivalent with  $x^2 - (gy)x + 2y - 1 = 0$ . We know  $x$  is one root of the equation. Let  $R$  be the other root. Using Vieta's formulas, we obtain the following system of equations:

$$\begin{aligned}x + R &= gy \\ xR &= 2y - 1.\end{aligned}$$

**3 points.**

From the first equation we get that  $R$  is an integer, and from the second equation we get that it is a positive integer.

**1 point.**

Using the same inequality as in Solution 1, we get that  $gy \leq 2y$ , which implies  $g = 1$  or  $g = 2$ .

**3 points.**

We now split into two cases:

1. If  $g = 1$ , then  $x^2 + 2y - 1 = xy \implies x^2 - 1 = y(x - 2) \implies x - 2 \mid x^2 - 1 \implies x - 2 \mid 3$ . This has only two solutions, both of which are true by an easy check:  $x = 5, y = 8$  or  $x = 3, y = 8$ .

**2 points.**

2. If  $g = 2$ , then  $x^2 + 2y - 1 = 2xy \implies x^2 - 1 = 2y(x - 1) \implies x = 1$  or  $x = 2y - 1$ , and  $y$  can be any positive integer.

**1 point.**

Therefore, the set of solutions is

$$(x, y) \in \{(1, t), (2t - 1, t), (3, 8), (5, 8) \mid t \in \mathbb{N}\}$$

**Third Solution.** Let  $(x, y)$  be a solution, and let  $\frac{x^2+2y-1}{xy} = g$ . This equation is equivalent with  $x^2 - (gy)x + 2y - 1 = 0$ .

**1 point.**

The condition of the problem is satisfied if and only if the discriminant is a square of a positive integer.

**1 point.**

Let the discriminant be equal to  $k^2$ . Then

$$\begin{aligned}k^2 = g^2y^2 - 8y + 4 &\iff k^2 = (gy - 2)^2 + 4gy - 8y \iff \\(k - gy + 2)(k + gy - 2) &= 4y(g - 2).\end{aligned}$$

**2 points.**

We now split into 3 cases depending on the size of  $g$ .

1. If  $g > 2$ , then  $4y(g - 2) > 0$  and  $k + gy - 2 > 0$ , which implies

$$k - gy + 2 > 0.$$

**1 point.**

Adding  $2gy - 4y = 2y(g - 2)$  to the both sides, we obtain

$$\begin{aligned}k + gy - 2 \geq k + gy + 2 - 4y > 2y(g - 2) &= \frac{(k + gy - 2)(k - gy + 2)}{2} \implies \\k - gy + 2 < 2,\end{aligned}$$

so the only possibility is  $k - gy + 2 = 1$ ,  $k + gy - 2 = 4y(g - 2)$ .

However, summing up the two equalities yields  $2k = 4y(g - 2) + 1$ , which is a contradiction modulo 2. Therefore, there are no solutions in this case.

**2 points.**

2. If  $g = 1$ , then  $x^2 + 2y - 1 = xy \implies x^2 - 1 = y(x - 2) \implies x - 2 \mid x^2 - 1 \implies x - 2 \mid 3$ . This has only two solutions, both of which are true by an easy check:  $x = 5, y = 8$  or  $x = 3, y = 8$ .

**2 points.**

3. If  $g = 2$ , then  $x^2 + 2y - 1 = 2xy \implies x^2 - 1 = 2y(x - 1) \implies x = 1$  or  $x = 2y - 1$ , and  $y$  can be any positive integer.

**1 point.**

#### Notes on marking:

- Points from separate solutions can not be added. The competitor should be awarded the maximum of the points scored in the 2 presented solutions, or an appropriate number of points on an alternative solution.

**Problem 3.** Let  $ABC$  be an acute triangle with  $|AB| < |AC|$  and orthocenter  $H$ . The circle with center  $A$  and radius  $|AC|$  intersects the circumcircle of  $\triangle ABC$  at point  $D$  and the circle with center  $A$  and radius  $|AB|$  intersects the segment  $\overline{AD}$  at point  $K$ . The line through  $K$  parallel to  $CD$  intersects  $BC$  at the point  $L$ . If  $M$  is the midpoint of  $\overline{BC}$  and  $N$  is the foot of the perpendicular from  $H$  to  $AL$ , prove that the line  $MN$  bisects the segment  $\overline{AH}$ .

(Miroslav Marinov)

First Sketch.

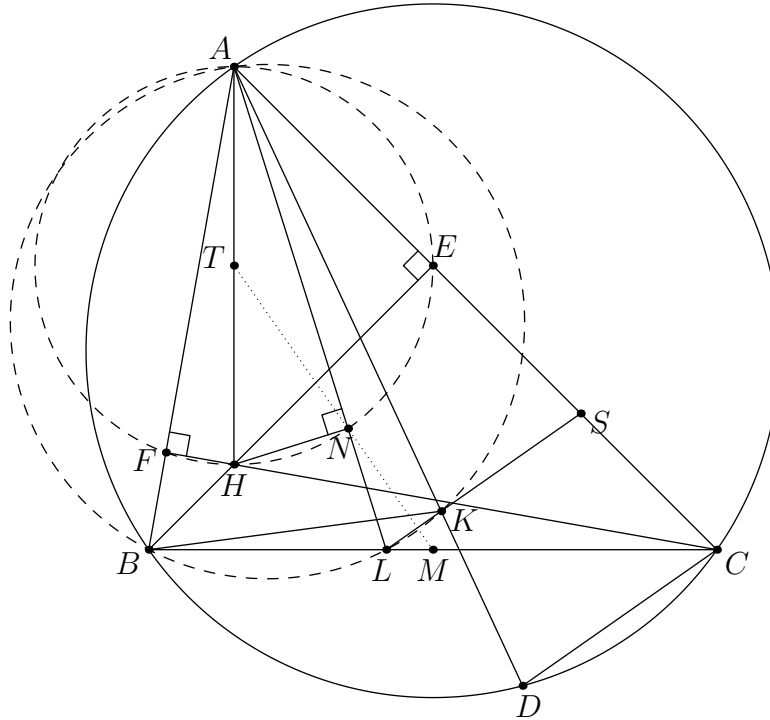

**First Solution.** We start with the following:

*Lemma 1.*  $AL$  is the angle bisector of  $\angle BAC$ .

*Proof:* Since  $A, B, C$  and  $D$  lie on the same circle we obtain that  $\angle ABC = \angle ADC = \angle ACD$ .

1 point.

From that we get the following three equations:

$$\angle CAD = 180^\circ - 2\angle ADC = 180^\circ - 2\angle ABC$$

1 point.

$$\angle BCD = \angle BAD = \angle BAK = \angle BAC - (180^\circ - 2\angle ABC) = \angle ABC - \angle ACB$$

1 point.

$$\angle ABK = \angle AKB = 90^\circ - \frac{\angle BAK}{2} = 90^\circ - \frac{\angle ABC - \angle ACB}{2}$$

1 point.

Next from  $LK \parallel CD$  it follows that  $\angle CLK = \angle LCD = \angle BCD = \angle BAK$  so  $A, B, L$  and  $K$  are concyclic.

1 point.

Now we have

$$\angle BAL = \angle BAK - \angle LAK = \angle BAK - \angle LBK = (\angle ABC - \angle ACB) - (\angle ABC - \angle ABK) = \frac{\angle BAC}{2}$$

hence  $AL$  is the angle bisector of  $\angle BAC$ . □

1 point.

Let  $E$  and  $F$  be the feet of the altitudes from  $B$  and  $C$  in  $\triangle ABC$ . Observe that  $\angle AEH = \angle AFH = \angle ANH = 90^\circ$  so  $A, E, H, N$  and  $F$  lie on the circle with diameter  $\overline{AH}$ .

1 point.

Since  $AL$  is the angle bisector of  $\angle BAC$  it follows that  $|NE| = |NF|$ .

1 point.

Denote by  $T$  the midpoint of  $\overline{AH}$ . Since  $T$  is the circumcenter of  $AEHNF$  we get  $|TE| = |TF|$ .

1 point.

Also since  $\angle BEC = \angle CFB$ ,  $E$  and  $F$  lie on the circle with diameter  $\overline{BC}$  from where we get  $|ME| = |MF|$  so  $M$ ,  $N$  and  $T$  lie on the bisector of  $\overline{EF}$ .

1 point.

**Alternative proof of Lemma 1.**

Similarly as in the first proof, we obtain that  $\angle ABC = \angle ADC = \angle ACD$ .

1 point.

Let  $S$  be the intersection of  $KL$  and  $AC$ . Since  $LS \parallel DC$ , we have  $\angle ASL = \angle ACD = \angle ABC = \angle ABL$ .

2 points.

We also get  $\angle AKS = \angle ADC = \angle ASK$ , hence  $|AS| = |AK| = |AB|$ .

1 point.

Since  $B, L, S$  are not collinear (this is since  $SL$  is parallel to  $CD$ , which in turn isn't parallel to  $BC$  since  $|AB| < |AC|$ ), we may conclude that  $\triangle ABL$  and  $\triangle ASL$  are congruent. The claim now follows.  $\square$

2 points.

**Second Sketch.**

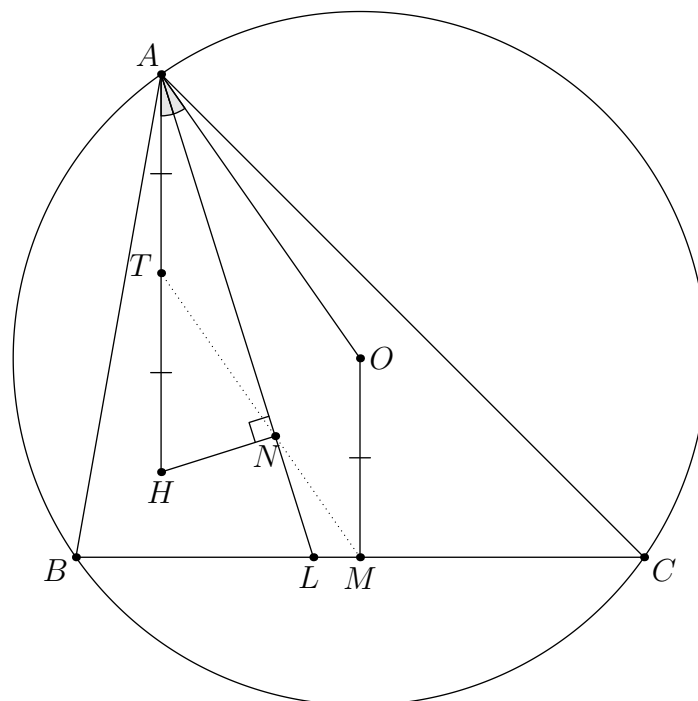

**Second Solution.** We get similarly as in the **First Solution** that  $AL$  is the angle bisector of  $\angle BAC$ .

6 points.

Denote by  $T$  the midpoint of  $\overline{AH}$ . As  $\triangle HNA$  is right-angled, we have that  $\angle NTH = 2\angle NAH$ .

1 point.

Denote by  $O$  the circumcenter of  $\triangle ABC$ . It is known that (as a consequence of existence of Euler line)

$$|AH| = 2|OM| \implies |AT| = \frac{|AH|}{2} = |OM|$$

and as  $AT$  and  $OM$  are both orthogonal to  $BC$ , they are parallel, so  $ATMO$  is a parallelogram.

1 point.

Now as  $\angle HAB = 90^\circ - \angle ABC = \angle OAC$ , we know that  $AL$  is the angle bisector of  $\angle OAH$ .

1 point.

Then we have that  $\angle MTH = \angle OAH = 2\angle NAH = \angle NTH$  and we conclude that  $T$ ,  $N$  and  $M$  are collinear.

1 point.

**Notes on marking:**

- If a student has a partial solution with analytic methods, only points for proving facts that can be expressed in geometric ways and lead to a complete solution can be awarded.

**Problem 4.** Let  $n$  be a positive integer. Ana and Banana are playing the following game:

First, Ana arranges  $2n$  cups in a row on a table, each facing upside-down. She then places a ball under a cup and makes a hole in the table under some other cup. Banana then gives a finite sequence of commands to Ana, where each command consists of swapping two adjacent cups in the row.

Her goal is to achieve that the ball has fallen into the hole during the game. Assuming Banana has no information about the position of the hole and the position of the ball at any point, what is the smallest number of commands she has to give in order to achieve her goal?

(Adrian Beker)

**First Solution.** We claim that the minimum number of commands is  $n(3n - 2)$ .

Call a finite sequence of commands *valid* if it results in the ball falling into the hole while performing the commands, regardless of the initial position of the ball and the position of the hole. Also call a position an *endpoint* if it is either the first or the last position in the row.

*Lemma 1.* A sequence of commands is valid if and only if it results in each cup visiting both endpoints.

*Proof.* Suppose there exists a cup  $c$  that hasn't visited an endpoint  $p$ . Then the ball fails to fall into the hole in the case when it is under  $c$  and the hole is at  $p$ . Hence, the sequence is not valid. Conversely, if each cup has visited both endpoints, by discrete continuity it must have also visited all positions in between. Hence, the ball has certainly fallen into the hole, so the sequence is valid.  $\square$

**2 points.**

Now consider a valid sequence of commands. We will show that it has length at least  $n(3n - 2)$ . Let  $C$  be the set of cups. For each  $c \in C$ , let  $k_c$  be the total number of commands involving  $c$ . Since each command involves two cups, the total number of commands is  $\frac{1}{2} \sum_{c \in C} k_c$ . So it suffices to show that  $\sum_{c \in C} k_c \geq 2n(3n - 2)$ .

**1 point.**

For each  $c \in C$ , let  $x_c$  be the number of commands involving  $c$  before its first visit to an endpoint. Similarly, let  $y_c$  be the number of commands involving  $c$  after its last visit to an endpoint. Since  $c$  visited both endpoints, the number of commands between its first and last visit to an endpoint must be at least  $2n - 1$ . Hence,  $k_c \geq x_c + y_c + 2n - 1$ .

**2 points.**

Now for each  $1 \leq i \leq 2n$ , let  $a_i$  be the cup at the  $i$ -th position from the left in the initial arrangement and similarly let  $b_i$  be the cup at the  $i$ -th position in the final arrangement. Then it follows that  $x_{a_i}, y_{b_i} \geq \min(i - 1, 2n - i)$  for all  $1 \leq i \leq 2n$ . Hence

$$\begin{aligned} \sum_{c \in C} x_c &= \sum_{i=1}^{2n} x_{a_i} \geq \sum_{i=1}^{2n} \min(i - 1, 2n - i) = n(n - 1), \\ \sum_{c \in C} y_c &= \sum_{i=1}^{2n} y_{b_i} \geq \sum_{i=1}^{2n} \min(i - 1, 2n - i) = n(n - 1), \\ \sum_{c \in C} k_c &\geq \sum_{c \in C} (x_c + y_c + 2n - 1) \geq n(n - 1) + n(n - 1) + 2n(2n - 1) = 2n(3n - 2), \end{aligned}$$

as desired. It remains to exhibit a valid sequence consisting of  $n(3n - 2)$  commands.

**2 points.**

*Lemma 2.* Consider  $n$  cups in a row. Then there is a sequence of  $\frac{n(n-1)}{2}$  commands resulting in each cup visiting the first position (and similarly for the last position).

*Proof.* For each  $1 \leq i \leq n$  in increasing order, for each  $1 \leq j < i$  in decreasing order, swap the cups currently at the  $j$ -th and  $(j + 1)$ -st positions. This clearly results in each cup visiting the first position and consist of  $\sum_{i=1}^n (i - 1) = \frac{n(n-1)}{2}$  commands, as desired (the case for the last position is analogous).  $\square$

*Corollary.* For  $2n$  cups in a row, there is a sequence of  $n(n - 1)$  steps resulting in each of the first  $n$  cups visiting the first position and each of the last  $n$  cups visiting the last position.

**2 points.**

Now first apply the algorithm from the corollary. Then for each  $1 \leq i \leq n$  in decreasing order, for each  $0 \leq j < n$  in increasing order, swap the cups currently at the  $(i + j)$ -th and  $(i + j + 1)$ -st positions. Finally, apply the algorithm from the corollary again. It is easy to see that the performed sequence of commands is valid and it has length  $n(n - 1) + n^2 + n(n - 1) = n(3n - 2)$ , as desired.

**1 point.**

**Second Solution.** The starting lemma and the proof of the upper bound are the same as in the first solution and are worth the same number of points. In this solution we present a different way to obtain the lower bound on the answer.

Let  $L$  be the set of cups that visit the first position before the last position and similarly let  $R$  be the set of cups that visit the last position before the first position. Then  $C$  is the disjoint union of  $L$  and  $R$ , in particular  $|L| + |R| = 2n$ .

**1 point.**

Now consider two cups  $a$  and  $b$  such that  $a$  is to the left of  $b$  at the beginning. Then note that  $a$  and  $b$  have to be swapped at least once since otherwise  $a$  wouldn't visit the last position (and  $b$  wouldn't visit the first position). Moreover, if  $a$  and  $b$  are swapped exactly once, then note that we must have  $a \in L, b \in R$ .

**2 points.**

Hence, it follows that the total number of swaps is at least

$$\binom{2n}{2} \cdot 2 - |L| \cdot |R| \geq 2n(2n - 1) - n^2 = n(3n - 2),$$

where we used the AM-GM inequality to obtain  $|L| \cdot |R| \leq \left(\frac{|L|+|R|}{2}\right)^2 = n^2$ .

**2 points.**

**Notes on marking:**

- Points obtained for different proofs of the lower bound are not additive, a student should be awarded the maximum of points obtained for a single approach.
- If a student states that a sequence of commands being valid is equivalent to each cup visiting each position, it should be awarded **0 points**. The reason for this is that this characterisation of valid sequences is trivial and not directly useful, whereas both solutions extensively make use of the characterisation presented in Lemma 1.

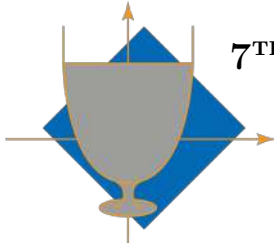

**7<sup>TH</sup> EUROPEAN MATHEMATICAL CUP**  
 8<sup>th</sup> December 2018 - 16<sup>th</sup> December 2018  
 Senior Category



**Problem 1.** A partition of a positive integer is *even* if all its elements are even numbers. Similarly, a partition is *odd* if all its elements are odd. Determine all positive integers  $n$  such that the number of even partitions of  $n$  is equal to the number of odd partitions of  $n$ .

*Remark:* A *partition* of a positive integer  $n$  is a non-decreasing sequence of positive integers whose sum of elements equals  $n$ . For example,  $(2, 3, 4)$ ,  $(1, 2, 2, 2, 2)$  and  $(9)$  are partitions of 9.

(Ivan Novak)

**Problem 2.** Let  $ABC$  be a triangle with  $|AB| < |AC|$ . Let  $k$  be the circumcircle of  $\triangle ABC$  and let  $O$  be the center of  $k$ . Point  $M$  is the midpoint of the arc  $\widehat{BC}$  of  $k$  not containing  $A$ . Let  $D$  be the second intersection of the perpendicular line from  $M$  to  $AB$  with  $k$  and  $E$  be the second intersection of the perpendicular line from  $M$  to  $AC$  with  $k$ . Points  $X$  and  $Y$  are the intersections of  $CD$  and  $BE$  with  $OM$  respectively. Denote by  $k_b$  and  $k_c$  circumcircles of triangles  $BDX$  and  $CEY$  respectively. Let  $G$  and  $H$  be the second intersections of  $k_b$  and  $k_c$  with  $AB$  and  $AC$  respectively. Denote by  $k_a$  the circumcircle of triangle  $AGH$ .

Prove that  $O$  is the circumcenter of  $\triangle O_a O_b O_c$ , where  $O_a, O_b, O_c$  are the centers of  $k_a, k_b, k_c$  respectively.

(Petar Nizić-Nikolac)

**Problem 3.** For which real numbers  $k > 1$  does there exist a bounded set of positive real numbers  $S$  with at least 3 elements such that

$$k(a - b) \in S$$

for all  $a, b \in S$  with  $a > b$ ?

*Remark:* A set of positive real numbers  $S$  is *bounded* if there exists a positive real number  $M$  such that  $x < M$  for all  $x \in S$ .

(Petar Nizić-Nikolac)

**Problem 4.** Let  $x, y, m, n$  be integers greater than 1 such that

$$\underbrace{x^{x^{x^{\cdot^{\cdot^{\cdot^x}}}}}}_{m \text{ times}} = \underbrace{y^{y^{y^{\cdot^{\cdot^{\cdot^y}}}}}}_{n \text{ times}}.$$

Does it follow that  $m = n$ ?

*Remark:* This is a tetration operation, so we can also write  ${}^m x = {}^n y$  for the initial condition.

(Petar Nizić-Nikolac)

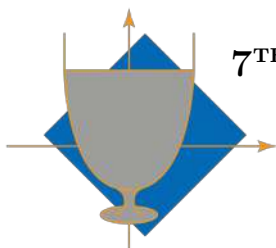

**7<sup>TH</sup> EUROPEAN MATHEMATICAL CUP**  
8<sup>th</sup> December 2018 - 16<sup>th</sup> December 2018  
Senior Category



## Problems and Solutions

**Problem 1.** A partition of a positive integer is *even* if all its elements are even numbers. Similarly, a partition is *odd* if all its elements are odd. Determine all positive integers  $n$  such that the number of even partitions of  $n$  is equal to the number of odd partitions of  $n$ .

*Remark:* A *partition* of a positive integer  $n$  is a non-decreasing sequence of positive integers whose sum of elements equals  $n$ . For example,  $(2, 3, 4)$ ,  $(1, 2, 2, 2, 2)$  and  $(9)$  are partitions of 9.

(Ivan Novak)

**Solution.** Answer:  $n \in \{2, 4\}$ .

We first notice that if  $n$  is a solution,  $n$  must be even, otherwise there are no even partitions of  $n$ , and  $(n)$  is an odd partition, so the number of odd partitions is greater than the number of even partitions.

**1 point.**

We now construct an injection  $f$  from the set of even partitions of  $n$  of cardinality  $k$  to odd partitions of  $n$  of cardinality  $2k$ .

If  $p = (a_1, \dots, a_k)$ , where  $2 \leq a_1 \leq a_2 \leq \dots \leq a_k$  is an even partition, let

$$f(p) = (\underbrace{1, \dots, 1}_{k \text{ times}}, a_1 - 1, \dots, a_k - 1).$$

**5 points.**

Obviously,  $f(p)$  is an odd partition of  $n$ . It is easy to see that  $f$  is injective because if  $f(p) = f(q)$  then the largest  $k$  elements of  $f(p)$  and  $f(q)$  are equal, and then  $p$  and  $q$  must be equal.

**2 points.**

Number of odd partitions is equal to the number of even partitions if and only if  $f$  is surjective.

**1 point.**

It can be checked that for  $n = 2$ ,  $n = 4$ ,  $f$  is a bijection. Check (no points deducted if missing):

$$\begin{array}{l} \underline{n = 2} \\ (2) \rightarrow (1, 1) \end{array}$$

$$\begin{array}{l} \underline{n = 4} \\ (4) \rightarrow (1, 3) \\ (2, 2) \rightarrow (1, 1, 1, 1) \end{array}$$

For  $n > 4$ , partition  $(3, n - 3)$  is not in the image of  $f$ , since every element of the image contains at least one number 1, so the number of even partitions is equal to the number of odd partitions if and only if  $n \in \{2, 4\}$ .

**1 point.**

### Notes on marking:

- Stating that  $n = 2, 4$  are the only solutions on its own is worth **0 points**.
- Clearly attempting to construct an injection from the set of even partitions to the set of odd partitions without success is worth **1 point**.

**Problem 2.** Let  $ABC$  be a triangle with  $|AB| < |AC|$ . Let  $k$  be the circumcircle of  $\triangle ABC$  and let  $O$  be the center of  $k$ . Point  $M$  is the midpoint of the arc  $\widehat{BC}$  of  $k$  not containing  $A$ . Let  $D$  be the second intersection of the perpendicular line from  $M$  to  $AB$  with  $k$  and  $E$  be the second intersection of the perpendicular line from  $M$  to  $AC$  with  $k$ . Points  $X$  and  $Y$  are the intersections of  $CD$  and  $BE$  with  $OM$  respectively. Denote by  $k_b$  and  $k_c$  circumcircles of triangles  $BDX$  and  $CEY$  respectively. Let  $G$  and  $H$  be the second intersections of  $k_b$  and  $k_c$  with  $AB$  and  $AC$  respectively. Denote by  $k_a$  the circumcircle of triangle  $AGH$ .

Prove that  $O$  is the circumcenter of  $\triangle O_a O_b O_c$ , where  $O_a, O_b, O_c$  are the centers of  $k_a, k_b, k_c$  respectively.

(Petar Nizić-Nikolac)

First Sketch.

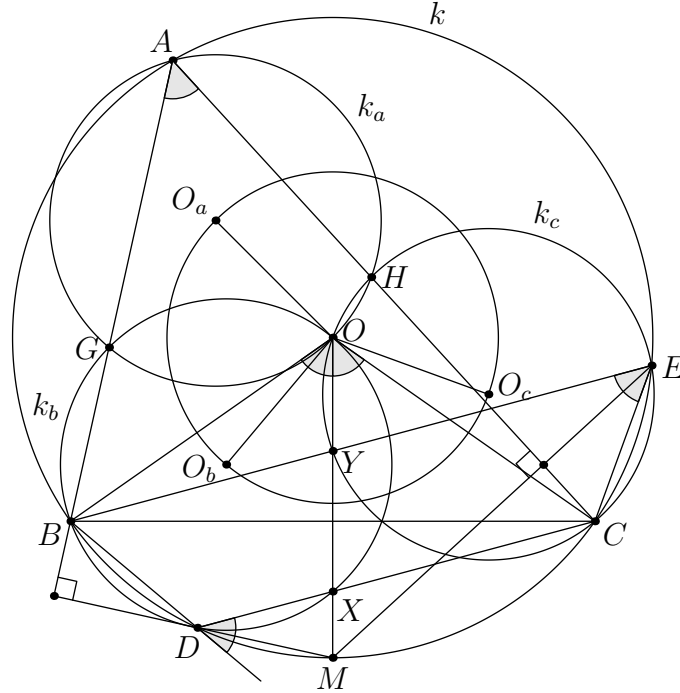

**First Solution.** We introduce standard angle notation,  $\angle CAB = \alpha$ ,  $\angle ABC = \beta$  and  $\angle BCA = \gamma$ .

As  $M$  is midpoint of arc  $\widehat{BC}$ , we know that  $\angle MOB = \angle COM = \frac{\angle COB}{2} = \angle CAB = \alpha$ , so

$$180^\circ - \angle BDX = 180^\circ - \angle BDC = \angle BAC = \angle BOM = \angle BOX$$

implying that  $BDXO$  is a cyclic quadrilateral. Analogously we get that  $CEYO$  is a cyclic quadrilateral.

**2 points.**

Another property of  $M$  being a midpoint of arc  $\widehat{BC}$  is that  $\angle CAM = \angle MAB = \frac{\alpha}{2}$ , so

$$\angle DAB = 180^\circ - \angle ABD - \angle BDA = (\angle BDM - 90^\circ) - \angle BCA = (90^\circ - \angle MAB) - \gamma = \left(90^\circ - \frac{\alpha}{2}\right) - \gamma = \frac{\beta - \gamma}{2} \quad (1)$$

$$\angle EAC = 180^\circ - \angle CEA - \angle ACE = \angle ABC - (90^\circ - \angle CEM) = \beta - (90^\circ - \angle CAM) = \beta - \left(90^\circ - \frac{\alpha}{2}\right) = \frac{\beta - \gamma}{2} \quad (2)$$

Combining (1) and (2) we obtain that  $|BD| = |EC|$ .

**2 points.**

As  $B, C, D$  and  $E$  lie on circumcircle,  $|BO| = |CO| = |DO| = |EO|$ , thus  $\triangle BOD \cong \triangle COD$ . As  $k_b$  and  $k_c$  are circumcircles of triangles  $BOD$  and  $COE$  respectively, we conclude that  $k_b \cong k_c$ , thus  $|OO_b| = |OO_c|$ .

**2 points.**

Now see that

$$\angle AGO = \angle ODB = 90^\circ - \frac{\angle DOB}{2} = 90^\circ - \angle DAB \quad (3)$$

$$\angle OHA = 180^\circ - \angle OEC = 180^\circ - \left(90^\circ - \frac{\angle EOC}{2}\right) = 90^\circ + \angle EAC \quad (4)$$

Combining (1), (2), (3) and (4) we obtain that  $AGOH$  is a cyclic quadrilateral.

**2 points.**

Now as  $|AO| = |BO|$  and  $\angle AGO = \angle BDO$  we conclude that  $k_a \cong k_b$ , thus  $|OO_a| = |OO_b| = |OO_c|$ , so  $O$  is the circumcenter of  $\triangle O_a O_b O_c$ .

**2 points.**

**Second Sketch.**

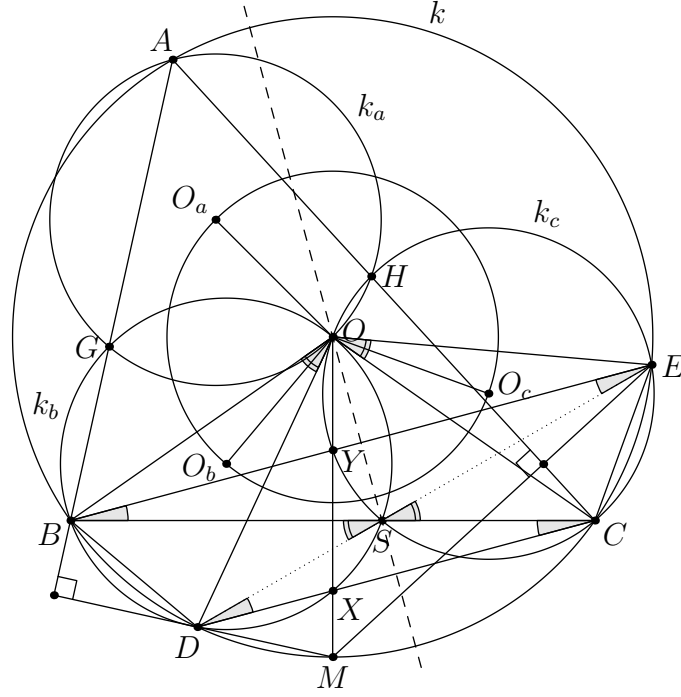

**Second Solution.** We introduce standard angle notation,  $\angle CAB = \alpha$ ,  $\angle ABC = \beta$  and  $\angle BCA = \gamma$ . As  $M$  is midpoint of arc  $\widehat{BC}$ , we know that  $\angle CAM = \angle MAB = \frac{\alpha}{2}$ , so

$$\angle DAB = 180^\circ - \angle ABD - \angle BDA = (\angle BDM - 90^\circ) - \angle BCA = (90^\circ - \angle MAB) - \gamma = \left(90^\circ - \frac{\alpha}{2}\right) - \gamma = \frac{\beta - \gamma}{2} \quad (1)$$

$$\angle EAC = 180^\circ - \angle CEA - \angle ACE = \angle ABC - (90^\circ - \angle CEM) = \beta - (90^\circ - \angle CAM) = \beta - \left(90^\circ - \frac{\alpha}{2}\right) = \frac{\beta - \gamma}{2} \quad (2)$$

Combining (1) and (2) we obtain that  $|BD| = |EC|$ , so  $BDCE$  is an isoscales trapezoid.

**2 points.**

Let  $S$  be the intersection of diagonals of  $BDCE$ . Then using (1) and (2) we have

$$\angle DSB = \angle SBE + \angle SDC = 2\angle EAC = 2\angle DAB = \angle DO_bD$$

so  $S$  lies on  $k_b$ . Analogously we get that  $S$  lies on  $k_c$  as well.

**2 points.**

Let  $O'$  be the second intersection of  $k_b$  and  $k_c$ . Then

$$\angle EO'B = \angle EO'S + \angle SO'B = 360^\circ - \angle SCE - \angle BDS = 2(180^\circ - \angle SCE) = 2(\angle EAB) = \angle EOB$$

and as  $k_b$  is symmetric to  $k_c$  over  $OS$  (perpendicular bisector of  $\overline{BE}$  and  $\overline{CE}$ ), we conclude that  $O$  and  $O'$  lie on that line so  $O \equiv O'$ , and we conclude that  $O$  is the second intersection of  $k_b$  and  $k_c$ .

**2 points.**

As  $k_b$  is symmetric to  $k_c$  over  $OS$ , we conclude that  $|OO_b| = |OO_c|$ .

**1 point.**

As  $k_a = (AGH)$ ,  $k_b = (BSOG)$  and  $k_c = (CEOS)$ , due to Miquel's theorem we have that  $O$  lies on  $k_a$ .

**1 point.**

Now as  $|AO| = |BO|$  and  $\angle AGO = \angle BDO$  we conclude that  $k_a \cong k_b$ , thus  $|OO_a| = |OO_b| = |OO_c|$ , so  $O$  is the circumcenter of  $\triangle O_aO_bO_c$ .

**2 points.**

**Notes on marking:**

- If a student has a partial solution with analytic methods, only points for proving facts that can be expressed in geometric ways and lead to a complete solution can be awarded.

**Problem 3.** For which real numbers  $k > 1$  does there exist a bounded set of positive real numbers  $S$  with at least 3 elements such that

$$k(a - b) \in S$$

for all  $a, b \in S$  with  $a > b$ ?

*Remark:* A set of positive real numbers  $S$  is *bounded* if there exists a positive real number  $M$  such that  $x < M$  for all  $x \in S$ .

(Petar Nizić-Nikolac)

**First Solution.** Set of solutions:

$$k \in \left\{ \frac{1 + \sqrt{5}}{2}, 2 \right\}$$

Verification:

- If  $k = \phi = \frac{1 + \sqrt{5}}{2}$  we can choose set  $\{\phi, 1 + \phi, 1 + 2\phi\}$ . It works as  $\phi(1 + \phi - \phi) = \phi$ ,  $\phi(1 + 2\phi - 1 - \phi) = \phi^2 = 1 + \phi$  and  $\phi(1 + 2\phi - \phi) = \phi + \phi^2 = 1 + 2\phi$  (all these properties are true as  $\phi$  is a root of the quadratic  $x^2 - x - 1 = 0$ ).
- If  $k = 2$  we can choose set  $\{2, 3, 4\}$ . It works as  $2(3 - 2) = 2$ ,  $2(4 - 3) = 2$  and  $2(4 - 2) = 4$ .

**1 point.**

Now we prove that these are the only possible values of  $k$ . Suppose  $k > 1$  such that all required properties are satisfied.

*Lemma 1.*  $k(a - b) \leq a$  for all  $a, b \in S$  with  $a > b$

*Proof.* Assume the opposite, that there exist  $a, b \in S$  with  $a > b$  such that  $k(a - b) > a$ . Fix  $b$  and denote  $f(x) = k(x - b)$ . We have  $f(a) > a$ . Consider these two conclusion for some  $x$  such that  $f(x) > x$ :

$$f(x) > x \implies k(x - b) - b > x - b \implies k(k(x - b) - b) - kb > k(x - b) - kb \implies f(f(x)) > f(x) \quad (1)$$

**1 point.**

$$f(x) > x \implies (k - 1)f(x) > (k - 1)x \implies k(f(x) - b) - k(x - b) > f(x) - x \implies f(f(x)) - f(x) > f(x) - x \quad (2)$$

**1 point.**

By (1) we have that  $f^n(a) > f^{n-1}(a) > \dots > f(a) > a > b$  so  $f^n(a) \in S, \forall n \in \mathbb{N}$ . On the other hand, by (2) we have  $f^k(a) - f^{k-1}(a) \geq f(a) - a$  for all natural  $k$ . Summing up for  $k$  from 1 to  $n$ , we obtain

$$f^n(a) - a = \sum_{k=1}^n (f^k(a) - f^{k-1}(a)) \geq n(f(a) - a)$$

However, this means that  $f^n(a) \in S$  is unbounded as  $n$  grows, which is impossible. Hence, the lemma is proved.  $\square$

**1 point.**

*Lemma 2.*  $S$  has a minimum and it is greater than 0

*Proof.* Now, denote  $m = \inf S$ . Let's first settle the case  $m = 0$ . However, then by fixing  $a$  and taking  $b$  small enough such that  $k(a - b) > a$  we contradict the lemma. Therefore, we have  $m > 0$ .

**1 point.**

Without loss of generality we can take that  $m = 1$  as we can scale the whole set. Assume that  $1 \notin S$ , and then there exists an infinite sequence of elements of  $S$  tending to 1, i.e., for every  $a \in S$  there exists  $b \in S$  with  $1 < b < a$ . Therefore,

$$k(a - b) > 1 \implies a > b + \frac{1}{k} \implies a > 1 + \frac{1}{k}$$

However, then every  $a$  in  $S$  is larger than  $1 + \frac{1}{k}$  so  $1 = \inf S \geq 1 + \frac{1}{k} > 1$ , which is a contradiction. Hence  $\min S = 1$ .  $\square$

**1 point.**

*Lemma 3.* For some  $x \in S$ , if  $x > G_{n-1}$  then  $x \geq G_n$  for all  $n \in \mathbb{N}$ , where  $G_n = 1 + \frac{1}{k} + \dots + \frac{1}{k^n}$

*Proof.* We prove by induction on  $n$ . Basis for  $n = 0$  is true as

$$k(x - 1) \geq \min S = 1 \implies x \geq 1 + \frac{1}{k}$$

Now we proceed with the inductive step. Take  $x > G_n$ . This implies that

$$k(x - 1) > k(G_n - 1) = G_{n-1}$$

Obviously,  $k(x - 1) \in S$ . However, by the induction hypothesis, it follows that  $k(x - 1) \geq G_n$  which rearranges into

$$x \geq \frac{1}{k}(G_n + k) = G_{n+1}$$

so the lemma is proved by mathematical induction.  $\square$

1 point.

Let  $T = \{G_0, G_1, G_2, \dots\}$ . Assume that exists some  $a \in S \setminus T$ . Then using Lemma 3 we get that

$$a > G_n \text{ and } a \notin T \implies a \geq G_{n+1} \text{ and } a \notin T \implies a > G_{n+1}$$

and as  $a \neq G_0 = 1 = \min S$ , then  $a \geq \sup T = \frac{k}{k-1}$ .

1 point.

However,  $a \leq \frac{k}{k-1}$  holds as a consequence of Lemma 2, so the only member of  $S \setminus T$  is  $\frac{k}{k-1}$ . Therefore,

$$S \subseteq \left\{ \frac{k}{k-1}, G_0, G_1, G_2, \dots \right\}$$

1 point.

However, if for some  $n > 1$ ,  $G_n \in S$ , then  $G_{n-1} = k(G_n - 1) \in S$ , so we have that

$$k(G_n - G_{n-1}) = \frac{1}{k^{n-1}} \in S$$

which is impossible due to  $k > 1$ , so we in fact have

$$S \subseteq \left\{ 1, \frac{k+1}{k}, \frac{k}{k-1} \right\}$$

and due to  $|S| \geq 3$  all three numbers must belong to the set (easy to see that they are distinct). However, then

$$k \left( \frac{k}{k-1} - \frac{k+1}{k} \right) = \frac{1}{k-1} \in \left\{ 1, \frac{k+1}{k}, \frac{k}{k-1} \right\}$$

which gives  $k \in \left\{ \frac{1+\sqrt{5}}{2}, 2 \right\}$ , both of which satisfy the condition by verification.

1 point.

**Second Solution.** Verification is the same and also worth 1 point. For a set  $A \subseteq \mathbb{R}^+$ , we will write  $\Delta A = \{a - b \mid a, b \in A, a > b\}$ . Suppose  $k > 1$  is such that there exists a set  $S$  with the required properties.

*Lemma 1.* If  $d \in \Delta S$  is not a maximal element, then  $kd \in \Delta S$ .

*Proof.* Let  $a, b \in S$  be such that  $a - b = d > 0$ . Since  $d$  is not maximal in  $\Delta S$ , either  $a$  is not maximal in  $S$  or  $b$  is not minimal in  $S$ . If the former is true, then  $\exists c \in S$  with  $c > a$ , hence  $k(c - a), k(c - b) \in S$ . But then  $k(c - b) - k(c - a) = k(a - b) = kd \in \Delta S$ , as desired. Otherwise,  $\exists c \in S$  with  $c < b$ , so  $k(b - c), k(a - c) \in S$ , hence  $k(a - c) - k(b - c) = k(a - b) = kd$ , so we are done.  $\square$

2 points.

*Lemma 2.*  $\Delta S$  is a finite geometric progression with common ratio  $k$ . In particular,  $S$  is finite.

*Proof.* First note that  $\Delta S$  must have a maximal element  $M$ . Indeed, otherwise we could take  $d \in \Delta S$  and inductively obtain  $k^n d \in \Delta S$  for all  $n \in \mathbb{N}$ , which is absurd since  $\Delta S$  is bounded as  $S$  is bounded.

1 point.

Now for any  $d \in \Delta S$ , take the maximal  $n \in \mathbb{N}_0$  such that  $k^n d \leq M$ . Then it follows inductively that  $k^i d \in \Delta S$  for  $0 \leq i \leq n$ . By maximality of  $n$ ,  $k^{n+1} d > M$ , so we must have  $k^n d = M$  (otherwise we would have  $k^{n+1} d \in \Delta S$  by the Lemma 1). It follows that  $d = \frac{M}{k^n}$  and also  $\frac{M}{k^i} \in \Delta S$  for all  $0 \leq i < n$ . Hence,  $\Delta S$  is a (possibly infinite) geometric progression with common ratio  $\frac{1}{k}$ .

2 points.

Suppose that  $\Delta S$  is infinite. Then  $S$  contains an infinite geometric progression with ratio  $\frac{1}{k}$ . Then for any  $a, b \in S$  with  $a > b$ , one can choose  $c$  in this progression with  $c < b$ , so that  $a - c > a - b$ . This contradicts the fact that  $\Delta S$  has a maximal element, so  $\Delta S$  must be finite.  $\square$

1 point.

Now by scaling WLOG assume that  $\Delta S = \{1, k, \dots, k^{m-1}\}$  for some  $m \in \mathbb{N}$ . Then  $\{k, k^2, \dots, k^m\} \subseteq S$ , hence  $\Delta\{k, k^2, \dots, k^m\} \subseteq \Delta S$ . But note that  $k^{i+1} - k^i < k^{i+2} - k^{i+1}$  for all  $1 \leq i < m - 1$  and  $k^m - k^i > k^m - k^{i+1}$  for all  $1 \leq i < m - 1$ , so it follows that  $|\Delta\{k, k^2, \dots, k^m\}| \geq 2m - 3$ . Hence,  $2m - 3 \leq m$ , i.e.  $m \leq 3$ .

1 point.

Now  $m \geq |S| - 1$ , so  $|S| \leq 4$ . If  $|S| = 4$ , then  $m = 3$  and it can easily be checked that  $S$  is an arithmetic progression, say with difference  $d > 0$ . But then  $\Delta S = \{d, 2d, 3d\}$ , which is not a geometric progression. Hence,  $|S| = 3$ .

**1 point.**

Now we can write  $S = \{a, b, c\}$ , with  $a < b < c$ . As  $k(b - a), k(c - b) < k(c - a)$  and  $k\Delta S \subseteq \{a, b, c\}$ , five cases arise:

- If  $k(b - a) = a, k(c - b) = a$  and  $k(c - a) = b$ . Then  $\frac{k+1}{k}a = b = k(c - a) = k(c - b) + k(b - a) = 2a$ , so  $k = 1$ . ✗
- If  $k(b - a) = a, k(c - b) = a$  and  $k(c - a) = c$ . Then  $\frac{k}{k-1}a = c = k(c - a) = k(c - b) + k(b - a) = 2a$ , so  $k = 2$ . ✓
- If  $k(b - a) = a, k(c - b) = b$  and  $k(c - a) = c$ . Then  $\frac{k+1}{k}a = b = \frac{k}{k+1}c = \frac{k^2}{(k+1)(k-1)}a$ , so  $k = \frac{1+\sqrt{5}}{2}$  or  $\frac{1-\sqrt{5}}{2}$ . ✓ or ✗
- If  $k(b - a) = b, k(c - b) = a$  and  $k(c - a) = c$ . Then  $b = \frac{k}{k-1}a = c$ , which is impossible. ✗
- If  $k(b - a) = b, k(c - b) = b$  and  $k(c - a) = c$ . Then  $\frac{k+1}{k}b = c = k(c - a) = k(c - b) + k(b - a) = 2b$ , so  $k = 1$ . ✗

**1 point.**

**Third Solution.** Verification is the same and also worth **1 point**. We use the same notation as in the **Second Solution**.

*Lemma 1.*  $S$  is finite.

*Proof.* Let  $m = \inf S, M = \sup S$  (these exist since  $S$  is bounded both below and above as a subset of  $\mathbb{R}$ ). Then note that  $\sup \Delta S = M - m$ . This holds since for any  $a, b \in S$  we have  $a - b \leq M - m$  and moreover given any  $\varepsilon > 0$ , there exist  $a, b \in S$  such that  $a > M - \frac{\varepsilon}{2}, b < m + \frac{\varepsilon}{2}$ , so that  $a - b > M - m - \varepsilon$ .

**1 point.**

Since  $k\Delta S \subseteq S$ , we have  $\sup(k\Delta S) \leq M$ , i.e.  $\sup \Delta S \leq \frac{M}{k}, M - m \leq \frac{M}{k}, m \geq \frac{k-1}{k}M$ .

Again since  $k\Delta S \subseteq S$ , we have  $\inf(k\Delta S) \geq m$ , i.e.  $\inf \Delta S \geq \frac{m}{k} \geq \frac{k-1}{k^2}M$ .

**1 point.**

So if  $a_1, a_2, \dots, a_n$  are some elements of  $S$  with  $m \leq a_1 < a_2 < \dots < a_n \leq M$ , we have  $a_{i+1} - a_i \geq \frac{k-1}{k^2}M$  for all  $1 \leq i < n$ , so we get

$$\frac{M}{k} \geq M - m \geq a_n - a_1 = \sum_{i=1}^{n-1} a_{i+1} - a_i \geq (n-1) \cdot \frac{k-1}{k^2}M,$$

hence  $n \leq \frac{2k-1}{k-1}$ . In particular,  $S$  is finite. □

**1 point.**

*Lemma 2.*  $|S| = 3$ .

*Proof.* Let  $a_1 < a_2 < \dots < a_n$  be the elements of  $S$ , and assume for the sake of contradiction that  $|S| \geq 4$ .

We know  $k(a_n - a_1) > k(a_{n-1} - a_1) > \dots > k(a_2 - a_1)$  are elements of  $S$ , and there are at least  $n - 2$  elements of  $S$  greater than  $k(a_2 - a_1)$ . This implies  $k(a_2 - a_1) \in \{a_1, a_2\}$ . Using a similar argument,  $k(a_3 - a_1) \in \{a_2, a_3\}$ ,  $k(a_3 - a_2) \in \{a_1, a_2\}$  and  $k(a_4 - a_1) \in \{a_3, a_4\}$ .

**2 points.**

If  $k(a_2 - a_1) = a_2$ , then  $k(a_3 - a_1) = a_3$ , so  $a_2 = a_1 \frac{k}{k-1} = a_3$ , which is impossible, therefore  $k(a_2 - a_1) = a_1$  which implies that  $a_2 = a_1(1 + \frac{1}{k})$ .

**1 point.**

If  $k(a_3 - a_1) = a_2$ , then  $a_3 = a_1 + \frac{a_2}{k} = a_1(1 + \frac{1}{k} + \frac{1}{k^2})$ , so  $k(a_3 - a_2) = ka_1(1 + \frac{1}{k} + \frac{1}{k^2} - 1 - \frac{1}{k}) = \frac{a_1}{k} < a_1$ , which is impossible. Therefore,  $k(a_3 - a_1) = a_3$  which implies that  $a_3 = a_1 \frac{k}{k-1}$ .

**1 point.**

Now, because  $k(a_4 - a_1) > k(a_3 - a_1) = a_3$ , we know that  $k(a_4 - a_1) = a_4$  as there are  $n - 4$  differences greater than this, but this implies  $a_4 = a_1 \frac{k}{k-1} = a_3$ , a contradiction. Therefore,  $|S| = 3$ . □

**1 point.**

Similar finish as in the **Second Solution** which is also worth **1 point**.

**Alternative proof of Lemma 2.**

*Fact.* Let  $A = \{a_1, a_2, \dots, a_n\}$  with  $a_1 < a_2 < \dots < a_n$  and  $n \geq 3$  be a finite set of real numbers such that  $|\Delta A| \leq |A|$ . Then either

- there exist  $j \in \{1, \dots, n-1\}$  and  $0 < d \leq a_{j+1} - a_j$  such that  $a_{i+1} - a_i = d$  for all  $1 \leq i < n$  with  $i \neq j$  or
- $a_2 - a_1 = a_n - a_{n-1}$  and there exists  $0 < d < a_2 - a_1$  such that  $a_{i+1} - a_i = d$  for all  $1 < i < n-1$ .

*Proof.* Take  $j \in \{1, \dots, n-1\}$  that maximizes  $a_{j+1} - a_j$ . Suppose first that  $j$  can be taken so that  $1 < j < n-1$ . If  $a_{t+1} - a_t = a_{j+1} - a_j$  for all  $1 \leq t < n$ , then we are done, so suppose  $\exists t \in \{1, \dots, n-1\}$  such that  $a_{t+1} - a_t < a_{j+1} - a_j$ .

Now call a sequence of pairs of indices  $(l_1, r_1), (l_2, r_2), \dots, (l_{n-1}, r_{n-1})$  a *path* if  $(l_1, r_1) = (j, j+1)$  and  $(l_{i+1}, r_{i+1}) \in \{(l_i, r_i + 1), (l_i - 1, r_i)\}$  for all  $1 \leq i < n-1$ . Define the *signature* of a path to be the sequence  $(a_{r_i} - a_{l_i})_{1 \leq i \leq n-1}$ .

We claim that any two paths have the same signature. Indeed, note that for any path,  $a_{t+1} - a_t, a_{r_1} - a_{l_1}, a_{r_2} - a_{l_2}, \dots, a_{r_{n-1}} - a_{l_{n-1}}$  is a strictly increasing sequence of  $n$  elements of  $\Delta A$ , so the elements of the signature are fixed since  $|\Delta A| \leq n$ .

Now given any  $p < j, q > j$ , we can choose two paths  $(l_i, r_i)$  and  $(l'_i, r'_i)$  such that  $(l_{q-p}, r_{q-p}) = (p, q)$  and  $(l'_{q-p}, r'_{q-p}) = (p+1, q+1)$ . By the previous observation, it follows that  $a_q - a_p = a_{q+1} - a_{p+1}$ , i.e.  $a_{p+1} - a_p = a_{q+1} - a_q$ . Since  $1 < j < n-1$ , it follows that  $a_{q+1} - a_q = a_2 - a_1$  for all  $q > j$  and also  $a_{p+1} - a_p = a_n - a_{n-1}$  for all  $p < j$ . Since  $a_2 - a_1 = a_n - a_{n-1}$ , we have  $a_{i+1} - a_i = a_2 - a_1$  for all  $i \neq j$ , as desired.

It remains to deal with the case when  $a_{i+1} - a_i < a_{j+1} - a_j$  for  $1 < i < n-1$ . Note that  $|\{a_{i+1} - a_i \mid 1 \leq i < n\}| \leq 2$  since otherwise we could choose  $1 \leq s, t < n$  and a path  $(l_i, r_i)$  such that  $a_{s+1} - a_s, a_{t+1} - a_t, a_{r_1} - a_{l_1}, a_{r_2} - a_{l_2}, \dots, a_{r_{n-1}} - a_{l_{n-1}}$  is a strictly increasing sequence of  $n+1$  elements of  $\Delta A$ , which is absurd. The claim now follows.  $\square$

**3 points.**

Now we proceed by proving  $|S| = 3$ . Suppose for the sake of contradiction that  $|S| \geq 4$ . Enumerate  $S$  as  $x_1 < x_2 < \dots < x_n$ , where  $n \geq 4$ . Since  $S$  satisfies the hypothesis of the lemma, we may consider the following cases:

**Case 1.**  $(x_i)$  is an arithmetic sequence

Let  $d$  be the difference of  $(x_i)$ . Then the enumeration of  $k\Delta S$  is an arithmetic subsequence of  $(x_i)$  of length  $n-1$ , with difference  $kd$ . Since  $n \geq 4$ , it is either  $x_1, \dots, x_{n-1}$  or  $x_2, \dots, x_n$ , so it must have difference  $d$ , contradiction.

**Case 2.**  $\exists a, b > 0, j \in \{1, \dots, n-1\}$  such that  $a < b, x_{j+1} - x_j = b$  and  $x_{i+1} - x_i = a$  for  $1 \leq i < n, i \neq j$

Then  $k\Delta S = \{ka, kb, k(b+a), \dots, k(b+(n-2)a)\}$ , where  $ka < kb < k(b+a) < \dots < k(b+(n-2)a)$ . Hence,  $x_2 - x_1 = k(b-a)$  and  $x_{i+1} - x_i = ka$  for  $1 < i < n$ . It follows that  $j = 1, k(b-a) = b$  and  $ka = a$ , which is absurd since  $k > 1$ .

**Case 3.**  $\exists a, b > 0$  such that  $a < b, x_2 - x_1 = x_n - x_{n-1} = b$  and  $x_{i+1} - x_i = a$  for  $1 < i < n-1$

Then  $k\Delta S = \{ka, kb, k(b+a), \dots, k(b+(n-3)a), k(2b+(n-3)a)\}$ , where  $ka < kb < \dots < k(b+(n-3)a) < k(2b+(n-3)a)$ . Hence,  $x_n - x_{n-1} = kb$ , which is absurd since  $k > 1$ .  $\square$

**2 points.**

**Notes on marking:**

- A student cannot be awarded with points from two different solutions.
- In all solutions, if a student states that verification "is trivial" it should be awarded **0 points**. However, it is enough to give examples of sets for two possible values of  $k$  and then the student should be awarded **1 point**. This point can be awarded even if student hasn't solved the problem completely.
- In **First Solution**, if a student writes explicitly that  $a \leq \frac{k}{k-1}$  without showing that  $S \subseteq \left\{ \frac{k}{k-1}, G_0, G_1, G_2, \dots \right\}$  it should also be awarded **1 point**.
- In **Second Solution**, if a student states that deduction from  $|S| = 3$  to  $k = \frac{1+\sqrt{5}}{2}$  or 2 "is trivial" it should be awarded **0 points**.
- In **Third Solution**, if a student states that  $|\Delta A| = |A| - 1$  iff  $A$  is an arithmetic sequence, it should be awarded **1 point**. However, if a student states just that  $|\Delta A| \geq |A| - 1$  for all sequences, it should be awarded **0 points**.
- In **Alternative proof of Lemma 2**, if a student states correctly the whole class of sequences satisfying  $|\Delta A| = |A|$ , it should be awarded **1 point**.
- If student's solution is true with fact that  $S$  is finite, it should be awarded at most **7 points**.
- If student proves that  $|S| \leq c$  for some  $c \in \mathbb{N}$  independent of  $k$ , it should be awarded **5 points** (**1 point** for verification is not included and can also be awarded separately).

**Problem 4.** Let  $x, y, m, n$  be integers greater than 1 such that

$$\underbrace{x^{x^{x^{\cdot^{\cdot^{\cdot^x}}}}}}_{m \text{ times}} = \underbrace{y^{y^{y^{\cdot^{\cdot^{\cdot^y}}}}}}_{n \text{ times}}.$$

Does it follow that  $m = n$ ?

*Remark:* This is a tetration operation, so we can also write  ${}^m x = {}^n y$  for the initial condition.

(Petar Nizić-Nikolac)

**Solution.** Yes, it does. Assume for the sake of contradiction that  $x < y$ . Then  $m > n$ . Define function  $f$  recursively

$$f(r) = \begin{cases} f(\log_x(r)) + 1 & \text{if } \log_x(r) \in \mathbb{N} \\ 0 & \text{else} \end{cases}$$

for example, if  $x = 2$ , then  $f(256) = f(2^{2^3}) = 2$ . Essentially it is the least possible height of an exponent different from  $x$ .

*Lemma 1.*  $f(y) \geq 1$ .

*Proof.* Let  $p$  be a prime number such that  $p \mid x$  (it exists as  $x > 1$ ). Then  $p \mid y$ , so write  $x = p^a \cdot x'$  and  $y = p^b \cdot y'$ , where  $p \nmid x', y'$ . Let  $a' = \frac{a}{(a,b)}$  and  $b' = \frac{b}{(a,b)}$ . Let  $v_p(r)$  denote the largest integer such that  $p^{v_p(r)} \mid r$ . Then

$$\begin{aligned} v_p({}^m x) = v_p({}^n y) &\implies v_p\left((p^a)^{m-1} x\right) = v_p\left((p^b)^{n-1} y\right) \implies a \cdot {}^{m-1} x = b \cdot {}^{n-1} y \implies x^{a \cdot {}^{m-1} x} = x^{b \cdot {}^{n-1} y} \implies \\ &\implies ({}^m x)^a = x^{b \cdot {}^{n-1} y} \implies ({}^n y)^a = x^{b \cdot {}^{n-1} y} \implies y^{a \cdot {}^{n-1} y} = x^{b \cdot {}^{n-1} y} \implies y^a = x^b \implies y^{a'} = x^{b'} \end{aligned}$$

so there exists  $z$  such that  $x = z^{a'}$  and  $y = z^{b'}$ .

**2 points.**

As  $1 \leq a' < b'$  and  $(a', b') = 1$ , then

$$a \cdot {}^{m-1} x = b \cdot {}^{n-1} y \implies \frac{b'}{a'} = \frac{b}{a} = \frac{n-1}{m-1} = \frac{(z^{b'})^{n-2y}}{(z^{a'})^{m-2x}} = z^{b' \cdot n - 2y - a' \cdot m + 2x} \implies a' \mid b' \implies a' = 1 \implies y = x^{b'}$$

so we conclude that  $f(y) \geq 1$ . □

**1 point.**

*Lemma 2.*  $f({}^n y) \leq 2$ .

*Proof.* We have two cases depending on  $f(y)$ .

Case 1.  $f(y) = 1$

Write  $y = x^k$  where  $f(k) = 0$ . Then

$$f({}^n y) = f\left(\left(x^k\right)^{n-1} y\right) = f\left(x^{k \cdot n-1} y\right) = f\left(k \cdot {}^{n-1} y\right) + 1 = f\left(k \cdot x^{k \cdot n-2} y\right) + 1 = 1$$

as if  $k \cdot x^{k \cdot n-2} y = x^l \implies f(k) = 1$  or  $k = 1$  which is impossible, so  $f\left(k \cdot x^{k \cdot n-2} y\right) = 0$ .

**3 points.**

Case 2.  $f(y) \geq 2$

Write  $y = x^{x^k}$ . Then

$$f({}^n y) = f\left(\left(x^{x^k}\right)^{n-1} y\right) = f\left(x^{x^k \cdot n-1} y\right) = f\left(x^k \cdot {}^{n-1} y\right) + 1 = f\left(x^k \cdot x^{x^k \cdot n-2} y\right) + 1 = f\left(k + x^k \cdot {}^{n-2} y\right) + 2 = 2$$

as if  $k + x^k \cdot {}^{n-2} y = x^l \implies x^k \mid k$  which is impossible, so  $f\left(k + x^k \cdot {}^{n-2} y\right) = 0$ . □

**3 points.**

Using this conclusion we have that

$$2 \leq m = f({}^m x) = f(LHS) = f(RHS) = f({}^n y) \leq 2 \implies m = 2 \implies x^x < y^y = {}^2 y \leq {}^n y = x^x$$

which is impossible, so we conclude  $m = n$ .

**1 point.**

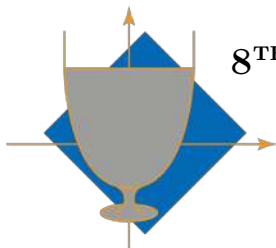

8<sup>TH</sup> EUROPEAN MATHEMATICAL CUP  
14<sup>th</sup> December 2019 - 22<sup>th</sup> December 2019  
Junior Category



**Problem 1.** Every positive integer is marked with a number from the set  $\{0, 1, 2\}$ , according to the following rule:

if a positive integer  $k$  is marked with  $j$ , then the integer  $k + j$  is marked with 0.

Let  $S$  denote the sum of marks of the first 2019 positive integers. Determine the maximum possible value of  $S$ .

(Ivan Novak)

**Problem 2.** Define a sequence  $x_1, x_2, x_3, \dots$  such that  $x_1 = \sqrt{2}$  and

$$x_{n+1} = x_n + \frac{1}{x_n} \text{ for } n \in \mathbb{N}.$$

Prove that the following inequality holds:

$$\frac{x_1^2}{2x_1x_2 - 1} + \frac{x_2^2}{2x_2x_3 - 1} + \dots + \frac{x_{2018}^2}{2x_{2018}x_{2019} - 1} + \frac{x_{2019}^2}{2x_{2019}x_{2020} - 1} > \frac{2019^2}{x_{2019}^2 + \frac{1}{x_{2019}^2}}.$$

(Ivan Novak)

**Problem 3.** Let  $ABC$  be a triangle with circumcircle  $\omega$ . Let  $l_B$  and  $l_C$  be two lines through the points  $B$  and  $C$ , respectively, such that  $l_B \parallel l_C$ . The second intersections of  $l_B$  and  $l_C$  with  $\omega$  are  $D$  and  $E$ , respectively. Assume that  $D$  and  $E$  are on the same side of  $BC$  as  $A$ . Let  $DA$  intersect  $l_C$  at  $F$  and let  $EA$  intersect  $l_B$  at  $G$ . If  $O, O_1$  and  $O_2$  are circumcenters of the triangles  $ABC, ADG$  and  $AEF$ , respectively, and  $P$  is the circumcenter of the triangle  $OO_1O_2$ , prove that  $l_B \parallel OP \parallel l_C$ .

(Stefan Lozanovski)

**Problem 4.** Let  $u$  be a positive rational number and  $m$  be a positive integer. Define a sequence  $q_1, q_2, q_3, \dots$  such that  $q_1 = u$  and for  $n \geq 2$ :

$$\text{if } q_{n-1} = \frac{a}{b} \text{ for some relatively prime positive integers } a \text{ and } b, \text{ then } q_n = \frac{a + mb}{b + 1}.$$

Determine all positive integers  $m$  such that the sequence  $q_1, q_2, q_3, \dots$  is eventually periodic for any positive rational number  $u$ .

*Remark:* A sequence  $x_1, x_2, x_3, \dots$  is *eventually periodic* if there are positive integers  $c$  and  $t$  such that  $x_n = x_{n+t}$  for all  $n \geq c$ .

(Petar Nizić-Nikolac)

Time: 240 minutes.

Each problem is worth 10 points.

The use of calculators or any other instruments except rulers and compasses is not permitted.

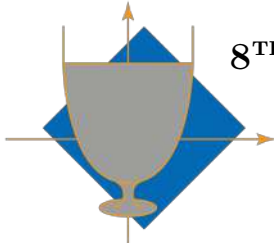

**8<sup>TH</sup> EUROPEAN MATHEMATICAL CUP**  
14<sup>th</sup> December 2019 - 22<sup>th</sup> December 2019  
Junior Category



## Problems and Solutions

**Problem 1.** Every positive integer is marked with a number from the set  $\{0, 1, 2\}$ , according to the following rule:

if a positive integer  $k$  is marked with  $j$ , then the integer  $k + j$  is marked with 0.

Let  $S$  denote the sum of marks of the first 2019 positive integers. Determine the maximum possible value of  $S$ .

*(Ivan Novak)*

**First Solution.** Consider an arbitrary marking scheme which follows the given rule.

Let  $a$  denote the number of positive integers from the set  $\{1, \dots, 2019\}$  which are marked with a 2,  $b$  the number of those marked with a 1, and  $c$  the number of those marked with a 0.

**1 point.**

We have  $S = 2a + b$ .

**1 point.**

For every positive integer  $j \in \{1, \dots, 2017\}$  which is marked with a 2, the number  $j + 2$  is marked with a 0. This implies that the number of positive integers less than 2017 marked with 2 is less than or equal to  $c$ .

**1 point.**

Hence, this implies  $a \leq c + 2$ . We then have

$$S = 2a + b \leq a + b + c + 2 = 2019 + 2 = 2021.$$

**3 points.**

Consider the following marking scheme:

$$210|210|210|\underbrace{2200|2200|2200 \dots 2200}_{502 \text{ blocks of } 2200}|22|0000 \dots$$

Here the  $i$ -th digit in the sequence denotes the mark of positive integer  $i$ . For this marking,  $S = 2021$ , and therefore 2021 is the maximum possible value of  $S$ .

**4 points.**

**Second Solution.** The marking scheme for which  $S = 2021$  is the same as in the first solution.

**4 points.**

Let  $S_n$  denote the sum of marks of first  $n$  positive integers, and let  $a_k$  denote the mark of  $k$ . Without loss of generality we may assume  $a_j = 0$  for all integers  $j \leq 0$ . We'll prove the following claim by strong mathematical induction:

for every positive integer  $n$ ,  $S_n \leq n + 2$  and if equality holds, then  $a_n = 2$ .

**1 point.**

The base cases for  $n \in \{1, 2\}$  trivially hold. Suppose the claim is true for all  $k \leq n$  for some  $n \geq 2$ .

Suppose there exists a marking scheme for which  $S_{n+1} \geq n + 4$ . Then if  $a_{n+1} < 2$ , we have  $S_n \geq n + 3$ , which is a contradiction. Hence,  $a_{n+1} = 2$ .

**1 point.**

This implies that  $a_n \in \{0, 2\}$ . If  $a_n = 0$ , then  $S_{n-1} \geq n + 2$ , which is a contradiction. So,  $a_n = 2$ .

**1 point.**

Now  $a_{n-1} = 0$  because both  $a_n$  and  $a_{n+1}$  are nonzero. We now have  $S_{n-2} \geq n$ , and by the induction hypothesis, it must hold that  $S_{n-2} = n$  and  $a_{n-2} = 2$ . However, this is in contradiction with  $a_n$  being nonzero. Hence,  $S_{n+1} \leq n + 3$ .

**1 point.**

Suppose  $S_{n+1} = n + 3$  and  $a_{n+1} \neq 2$ . If  $a_{n+1} = 0$ , then  $S_n \geq n + 3$ , which is a contradiction. Thus,  $a_{n+1} = 1$ .

**1 point.**

Then  $S_n = n + 2$ , which implies  $a_n = 2$ . Then we must have  $a_{n-1} = 0$ , and then  $S_{n-2} = n$ , which implies  $a_{n-2} = 2$ , but  $a_n$  is nonzero, which is a contradiction. Therefore, the claim is true for  $n + 1$ , which implies it is true for all positive integers. In particular,  $S_{2019} \leq 2021$ , which combined with the construction implies that the maximum value of  $S$  is 2021.

**1 point.**

**Notes on marking:**

- If a student forgets to write additional zeros beyond the first 2019 digits in his construction, but the construction is otherwise valid, he should be awarded all **4 points** for this part.
- There are many different optimal marking schemes. For example, 2200|210|210|...|210|22|000..., where the block |210| repeats 671 times.
- In the **Second Solution**, if the student writes only the first part of the induction hypothesis without the assumption that  $a_n = 2$  in the case of equality: he should be awarded **0 points**, unless he reaches additional conclusions which lead to the solution.
- In the **Second Solution**, if the student doesn't comment on the base case/cases at all, he should be deducted **1 point**.
- If the student proves any nontrivial lemma useful for any of the solutions, but the lemma itself isn't worth any points and the student wouldn't otherwise get any of the **6 points** given for proving the bound, he should get **1 point** for this part.

**Problem 2.** Let  $(x_n)_{n \in \mathbb{N}}$  be a sequence defined recursively such that  $x_1 = \sqrt{2}$  and

$$x_{n+1} = x_n + \frac{1}{x_n} \text{ for } n \in \mathbb{N}.$$

Prove that the following inequality holds:

$$\frac{x_1^2}{2x_1x_2 - 1} + \frac{x_2^2}{2x_2x_3 - 1} + \dots + \frac{x_{2018}^2}{2x_{2018}x_{2019} - 1} + \frac{x_{2019}^2}{2x_{2019}x_{2020} - 1} > \frac{2019^2}{x_{2019}^2 + \frac{1}{x_{2019}^2}}.$$

(Ivan Novak)

**First Solution.** Notice that by squaring the assertion  $x_{n+1} = x_n + \frac{1}{x_n}$  we obtain the equality  $x_{n+1}^2 = x_n^2 + \frac{1}{x_n^2} + 2 \implies x_n^2 + \frac{1}{x_n^2} = x_{n+1}^2 - 2$ , which implies that the right hand side equals  $\frac{2019^2}{x_{2020}^2 - 2}$ .

1 point.

On the other hand, we have

$$2x_nx_{n+1} - 1 = 2x_n(x_n + \frac{1}{x_n}) - 1 = 2x_n^2 + 1.$$

1 point.

This implies that the sum on the left hand side can be written as

$$\frac{1}{2 + \frac{1}{x_1^2}} + \frac{1}{2 + \frac{1}{x_2^2}} + \dots + \frac{1}{2 + \frac{1}{x_{2019}^2}}$$

1 point.

By squaring the given assertion, we get the equality  $2 + \frac{1}{x_n^2} = x_{n+1}^2 - x_n^2$ . This implies that the left hand side equals

$$\frac{1}{x_2^2 - x_1^2} + \frac{1}{x_3^2 - x_2^2} + \dots + \frac{1}{x_{2019}^2 - x_{2018}^2} + \frac{1}{x_{2020}^2 - x_{2019}^2}.$$

1 point.

Using the inequality between arithmetic and harmonic mean, we find that the left hand side is greater than or equal to

$$\frac{2019^2}{(x_2^2 - x_1^2) + (x_3^2 - x_2^2) + \dots + (x_{2020}^2 - x_{2019}^2)}.$$

4 points.

We now notice that the denominator is a telescoping sum and it equals  $x_{2020}^2 - x_1^2$ , which implies the right hand side equals

$$\frac{2019^2}{x_{2020}^2 - x_1^2} = \frac{2019^2}{x_{2020}^2 - 2},$$

which is exactly equal to the right hand side.

1 point.

The equality cannot hold because  $x_2^2 - x_1^2 \neq x_3^2 - x_2^2$ .

1 point.

**Second Solution.** As in the first solution, we obtain that the left hand side equals

$$\frac{1}{2 + \frac{1}{x_1^2}} + \frac{1}{2 + \frac{1}{x_2^2}} + \dots + \frac{1}{2 + \frac{1}{x_{2018}^2}} + \frac{1}{2 + \frac{1}{x_{2019}^2}}.$$

**2 points.**

Using the inequality between arithmetic and harmonic mean, we get that the left hand side is greater than or equal to

$$\frac{2019^2}{2 \cdot 2019 + \frac{1}{x_1^2} + \frac{1}{x_2^2} + \dots + \frac{1}{x_{2019}^2}}.$$

**4 points.**

We now prove by mathematical induction that

$$2 \cdot n + \frac{1}{x_1^2} + \frac{1}{x_2^2} + \dots + \frac{1}{x_{n-1}^2} = x_n^2$$

holds for every  $n \in \mathbb{N}$ .

**1 point.**

For  $n = 1$ , we have  $2 \cdot 1 = \sqrt{2^2}$ . Suppose the claim is true for some  $n \in \mathbb{N}$ . Then

$$x_{n+1}^2 = 2 + x_n^2 + \frac{1}{x_n^2} = 2 + 2n + \frac{1}{x_1^2} + \frac{1}{x_2^2} + \dots + \frac{1}{x_{n-1}^2} + \frac{1}{x_n^2},$$

where we used the induction hypothesis for the last equality. This proves the claim.

**2 points.**

In particular, for  $n = 2019$ , we have that

$$\frac{2019^2}{2 \cdot 2019 + \frac{1}{x_1^2} + \frac{1}{x_2^2} + \dots + \frac{1}{x_{2019}^2}} = \frac{2019^2}{x_{2019}^2 + \frac{1}{x_{2019}^2}},$$

which proves the inequality.

The equality cannot hold because  $\frac{1}{x_1^2} + 2 \neq \frac{1}{x_2^2} + 2$ .

**1 point.**

**Third Solution.** We prove by mathematical induction that for every  $n \geq 2$  the following inequality holds:

$$\frac{x_1^2}{2x_1x_2 - 1} + \frac{x_2^2}{2x_2x_3 - 1} + \dots + \frac{x_n^2}{2x_nx_{n+1} - 1} > \frac{n^2}{x_n^2 + \frac{1}{x_n^2}}.$$

For  $n = 2$ , the left hand side equals  $\frac{2}{5} + \frac{4.5}{10} = \frac{17}{20}$ , and the right hand side equals  $\frac{4}{\frac{9}{2} + \frac{2}{9}} = \frac{72}{85} < \frac{17}{20}$ , which proves the base case.

Suppose the claim was true for some  $n \in \mathbb{N}$ . Then by the induction hypothesis, we know that

$$\frac{x_1^2}{2x_1x_2 - 1} + \frac{x_2^2}{2x_2x_3 - 1} + \dots + \frac{x_n^2}{2x_nx_{n+1} - 1} + \frac{x_{n+1}^2}{2x_{n+1}x_{n+2} - 1} > \frac{n^2}{x_n^2 + \frac{1}{x_n^2}} + \frac{x_{n+1}^2}{2x_{n+1}x_{n+2} - 1}.$$

It suffices to prove that

$$\frac{n^2}{x_n^2 + \frac{1}{x_n^2}} + \frac{x_{n+1}^2}{2x_{n+1}x_{n+2} - 1} \geq \frac{(n+1)^2}{x_{n+1}^2 + \frac{1}{x_{n+1}^2}}.$$

**1 point.**

We now prove that  $2x_{n+1}x_{n+2} - 1 = 2x_{n+1}^2 + 1$  as in the first solution.

**1 point.**

We then have

$$\frac{n^2}{x_n^2 + \frac{1}{x_n^2}} + \frac{x_{n+1}^2}{2x_{n+1}x_{n+2} - 1} = \frac{n^2}{x_n^2 + \frac{1}{x_n^2}} + \frac{x_{n+1}^2}{2x_{n+1}^2 + 1} = \frac{n^2}{x_n^2 + \frac{1}{x_n^2}} + \frac{1}{2 + \frac{1}{x_{n+1}^2}}.$$

**1 point.**

By the inequality of arithmetic and harmonic mean, this is greater than or equal to

$$\frac{(n+1)^2}{x_n^2 + \frac{1}{x_n^2} + 2 + \frac{1}{x_{n+1}^2}}.$$

**5 points.**

Notice that squaring the assertion  $x_{n+1} = x_n + \frac{1}{x_n}$ , we obtain

$$x_n^2 + \frac{1}{x_n^2} + 2 = x_{n+1}^2.$$

**1 point.**

This implies that

$$\frac{(n+1)^2}{x_n^2 + \frac{1}{x_n^2} + 2 + \frac{1}{x_{n+1}^2}} = \frac{(n+1)^2}{x_{n+1}^2 + \frac{1}{x_{n+1}^2}},$$

which is exactly equal to the right hand side. Therefore, the claim is proven by the principle of mathematical induction. In particular, the claim is true for  $n = 2019$ , which proves the inequality.

**1 point.**

**Notes on marking:**

- Points from separate solutions can not be added. The student should be awarded the maximum of the points scored in the 3 presented solutions, or an appropriate number of points on an alternative solution.
- The third solution gives **5 points** for the use of AM-HM inequality as opposed to **4 points** in the first solution because in the third solution it is not necessary to comment the equality case. However, if a student has  $n = 1$  as a basis of induction and doesn't comment the equality case, he should be deducted **1 point** out of possible **5**.
- The point for proving that the equality cannot be achieved is only awarded if the student has proved the non-strict version of inequality.

**Problem 3.** Let  $ABC$  be a triangle with circumcircle  $\omega$ . Let  $l_B$  and  $l_C$  be two lines through the points  $B$  and  $C$ , respectively, such that  $l_B \parallel l_C$ . The second intersections of  $l_B$  and  $l_C$  with  $\omega$  are  $D$  and  $E$ , respectively. Assume that  $D$  and  $E$  are on the same side of  $BC$  as  $A$ . Let  $DA$  intersect  $l_C$  at  $F$  and let  $EA$  intersect  $l_B$  at  $G$ . If  $O$ ,  $O_1$  and  $O_2$  are circumcenters of the triangles  $ABC$ ,  $ADG$  and  $AEF$ , respectively, and  $P$  is the circumcenter of the triangle  $OO_1O_2$ , prove that  $l_B \parallel OP \parallel l_C$ .

(Stefan Lozanovski)

Sketch.

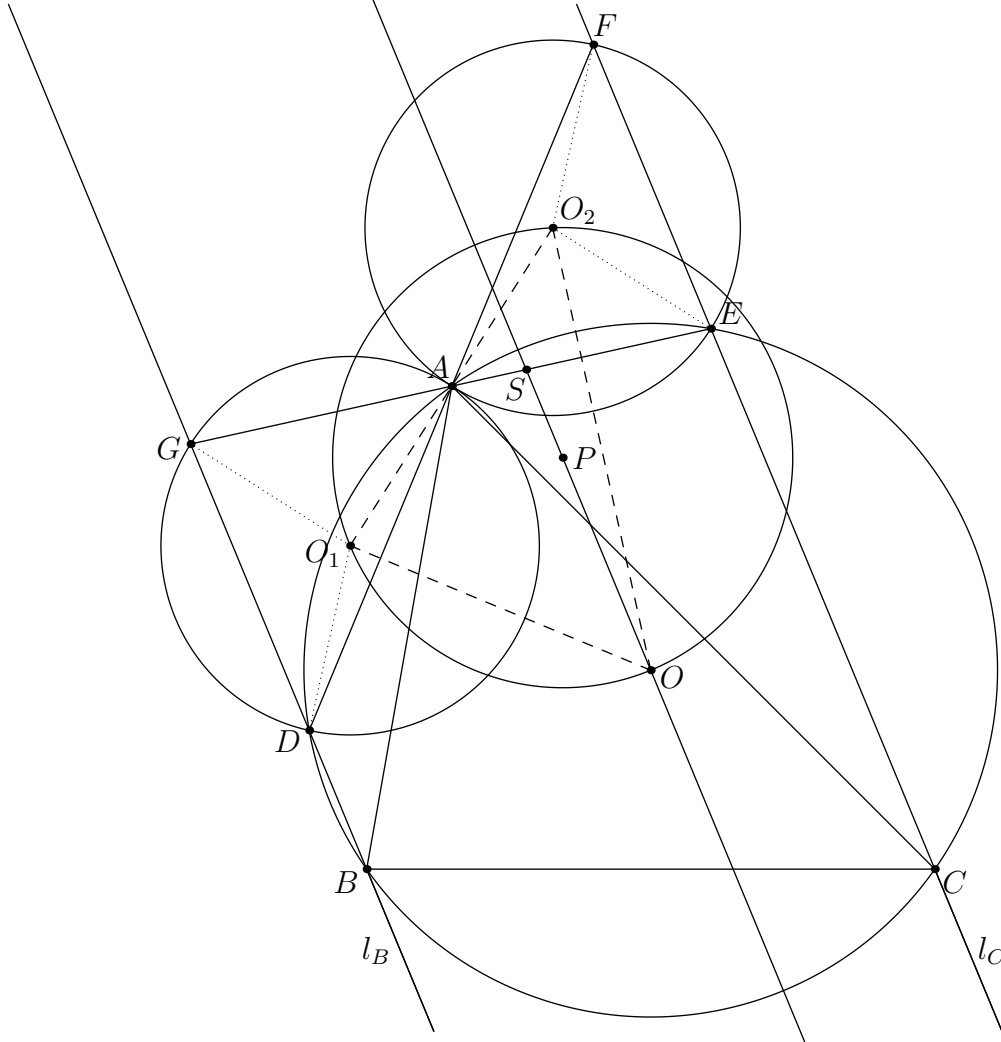

**Solution.** Let us write  $\angle BAC = \alpha, \angle ABC = \beta, \angle ACB = \gamma$ .

*Lemma.* Triangles  $AGD$  and  $AEF$  are similar to the triangle  $ABC$ .

*Proof.* As  $DBCDAE$  is a cyclic pentagon we have

$$\angle GDA = \angle BCA = \gamma.$$

1 point.

Now from  $l_B \parallel l_C$  we get that

$$\angle DBA = \angle DBC - \beta = 180^\circ - \angle BCE - \beta = \alpha + \gamma - \angle BCE = \alpha - \angle ACE$$

1 point.

so from the cyclicity

$$\angle BCD = \angle BAD = 180^\circ - \angle DBA - \angle ADB = 180^\circ - (\alpha - \angle ACE) - (180^\circ - \gamma) = \gamma - \alpha + \angle ACE$$

1 point.

Hence

$$\angle DAG = \angle DCE = \angle BCA - \angle BCD + \angle ACE = \alpha$$

1 point.

Therefore  $AGD$  is similar to the triangle  $ABC$ , and similarly for  $AEF$ .  $\square$

Now as  $G, A$  and  $E$  are collinear and  $F, A$  and  $D$  are collinear, using *Lemma* we get that  $O, O_1$  and  $O_2$  are collinear.

**1 point.**

As  $O_1$  is the circumcenter of the triangle  $ADG$  and  $O_1D$  is the bisector of the chord  $\overline{AD}$  we get that

$$\angle AO_1O = \frac{1}{2}\angle AO_1D = \angle AGD = \beta$$

and similarly  $\angle AO_1O = \gamma$ , so the triangle  $OO_1O_2$  is similar to the triangle  $ABC$ .

**2 points.**

Now as  $P$  is the circumcenter of the triangle  $OO_1O_2$  from the previous similarity we get that

$$\angle O_1OP = \angle BAO$$

**1 point.**

Hence

$$\angle DOP = \angle DOO_1 + \angle O_1OP = \angle DBA + \angle BAO = \angle DBA + \angle ABO = \angle DBO = \angle ODB$$

so  $l_B \parallel OP \parallel l_C$ .

**2 points.**

**Notes on marking:**

- If a student has a partial solution with analytic methods, only points for proving facts that can be expressed in geometric ways and lead to a complete solution can be awarded.

**Problem 4.** Let  $u$  be a positive rational number and  $m$  be a positive integer. Define a sequence  $q_1, q_2, q_3, \dots$  such that  $q_1 = u$  and for  $n \geq 2$ :

$$\text{if } q_{n-1} = \frac{a}{b} \text{ for some relatively prime positive integers } a \text{ and } b, \text{ then } q_n = \frac{a + mb}{b + 1}.$$

Determine all positive integers  $m$  such that the sequence  $q_1, q_2, q_3, \dots$  is eventually periodic for any positive rational number  $u$ .

*Remark:* A sequence  $x_1, x_2, x_3, \dots$  is *eventually periodic* if there are positive integers  $c$  and  $t$  such that  $x_n = x_{n+t}$  for all  $n \geq c$ .

(Petar Nizić-Nikolac)

**Solution.** We will prove that the sequence is eventually periodic if and only if  $m$  is odd.

Let  $a_1, a_2, a_3, \dots$  and  $b_1, b_2, b_3, \dots$  be sequences of numerators and denominators of  $q_1, q_2, q_3, \dots$  respectively when written in the irreducible form, i.e. for  $n \in \mathbb{N}$ :

$$q_n = \frac{a_n}{b_n} \quad \gcd(a_n, b_n) = 1$$

Say that there was *reduction in the  $n^{\text{th}}$  step* if  $\gcd(a_n + mb_n, b_n + 1) > 1$ .

**Case 1.**  $m$  is even

Set  $u = \frac{1}{1}$ . Assume for the sake of contradiction that  $q_1, q_2, q_3, \dots$  is eventually periodic. Then  $(b_n)_{n \in \mathbb{N}}$  is bounded so there is  $r > 1$  (pick the smallest one) such that there was reduction in the  $r^{\text{th}}$  step. Easy to see that

$$q_1 = \frac{1}{1}, q_2 = \frac{m+1}{2}, q_3 = \frac{3m+1}{3}, q_4 = \frac{6m+1}{4}, q_5 = \frac{10m+1}{5}, \dots, q_r = \frac{\binom{r}{2}m+1}{r}$$

**2 points.**

Now as  $m$  is even we have

$$\gcd(a_r + mb_r, b_r + 1) = \gcd\left(\binom{r}{2}m + 1 + mr, r + 1\right) = \gcd\left(\binom{r+1}{2}m + 1, r + 1\right) = \gcd\left((r+1)r\frac{m}{2} + 1, r + 1\right) = 1$$

so this is a contradiction, and hence it is not eventually periodic for any positive rational number  $u$ .

**1 point.**

**Case 2.**  $m$  is odd

Assume that there is  $r \in \mathbb{N}$  such that there was no reduction in the steps  $r, r+1, r+2$  and  $r+3$ . Then for  $i \in \{1, 2\}$ :

$$(a_{r+i+2}, b_{r+i+2}) \equiv (a_{r+i} + mb_{r+i} + mb_{r+i+1}, b_{r+i} + 1 + 1) \equiv (a_{r+i} + 2mb_{r+i} + m, b_{r+i} + 2) \equiv (a_{r+i} + 1, b_{r+i}) \pmod{2}$$

so at least one of the following pairs:  $(a_{r+1}, b_{r+1}), (a_{r+2}, b_{r+2}), (a_{r+3}, b_{r+3}), (a_{r+4}, b_{r+4})$  has both even entries which is impossible (as they are coprime). Hence there was at least one reduction in the steps  $r, r+1, r+2$  and  $r+3$ .

**2 points.**

Therefore for all  $n \geq 1$ :

$$\max\{b_{n+1}, b_{n+2}, b_{n+3}, b_{n+4}\} \leq \min\{b_{n+1}, b_{n+2}, b_{n+3}, b_{n+4}\} + 3 \leq \frac{1}{2} \max\{b_n, b_{n+1}, b_{n+2}, b_{n+3}\} + 3$$

so there exists  $C \geq 1$  such that  $b_n \leq 6$  for all  $n \geq C$ .

**2 points.**

Similarly for all  $n \geq C$ :

$$\max\{a_{n+1}, a_{n+2}, a_{n+3}, a_{n+4}\} \leq \min\{a_{n+1}, a_{n+2}, a_{n+3}, a_{n+4}\} + 3 \cdot 6m \leq \frac{1}{2} \max\{a_n, a_{n+1}, a_{n+2}, a_{n+3}\} + 18m$$

so there exists  $D \geq C$  such that  $a_n \leq 36m$  for all  $n \geq D$ .

**2 points.**

We conclude that for all  $n \geq D$  there are finitely many pairs  $(6 \cdot 36m = 216m)$  that  $(a_n, b_n)$  attains so it becomes eventually periodic for any positive rational number  $u$ .

**1 point.**

**Notes on marking:**

- **Case 1** and **Case 2** are always worth **3 points** and **7 points** respectively.

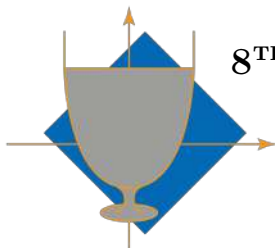

**8<sup>TH</sup> EUROPEAN MATHEMATICAL CUP**  
14<sup>th</sup> December 2019 - 22<sup>th</sup> December 2019  
Senior Category



**Problem 1.** For positive integers  $a$  and  $b$ , let  $\gcd(a, b)$  denote their greatest common divisor. Determine all pairs of positive integers  $(m, n)$  such that for any two positive integers  $x$  and  $y$  such that  $x \mid m$  and  $y \mid n$ ,

$$\gcd(x + y, mn) > 1.$$

*(Ivan Novak)*

**Problem 2.** Let  $n$  be a positive integer. A  $n \times n$  board consisting of  $n^2$  cells, each being a unit square coloured either black or white, is called *convex* if for every black coloured cell, both the cell directly to the left of it (if it exists) and the cell directly above it (if it exists) are also coloured black. We define the *beauty* of a board as the number of pairs of its cells  $(u, v)$  such that  $u$  is black,  $v$  is white and  $u$  and  $v$  are in the same row or column. Determine the maximum possible beauty of a convex  $n \times n$  board.

*(Ivan Novak)*

**Problem 3.** In an acute triangle  $ABC$  with  $|AB| \neq |AC|$ , let  $I$  be the incenter and  $O$  the circumcenter. The incircle is tangent to  $\overline{BC}$ ,  $\overline{CA}$  and  $\overline{AB}$  in  $D$ ,  $E$  and  $F$  respectively. Prove that if the line parallel to  $EF$  passing through  $I$ , the line parallel to  $AO$  passing through  $D$  and the altitude from  $A$  are concurrent, then the point of concurrence is the orthocenter of the triangle  $ABC$ .

*(Petar Nizić-Nikolac)*

**Problem 4.** Find all functions  $f : \mathbb{R} \rightarrow \mathbb{R}$  such that

$$f(x) + f(yf(x) + f(y)) = f(x + 2f(y)) + xy$$

for all  $x, y \in \mathbb{R}$ .

*(Adrian Beker)*

*Time: 240 minutes.*

*Each problem is worth 10 points.*

*The use of calculators or any other instruments except rulers and compasses is not permitted.*

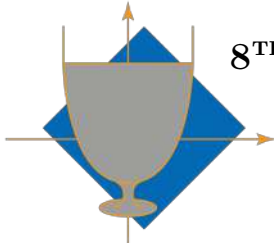

**8<sup>TH</sup> EUROPEAN MATHEMATICAL CUP**  
*14<sup>th</sup> December 2019 - 22<sup>th</sup> December 2019*  
Senior Category



## Problems and Solutions

**Problem 1.** For positive integers  $a$  and  $b$ , let  $M(a, b)$  denote their greatest common divisor. Determine all pairs of positive integers  $(m, n)$  such that for any two positive integers  $x$  and  $y$  such that  $x \mid m$  and  $y \mid n$ ,

$$M(x + y, mn) > 1.$$

*(Ivan Novak)*

**First Solution.** We will prove that there are no solutions. Let  $m$  and  $n$  be any positive integers.

Let  $P$  denote the product of all primes which divide  $n$  and don't divide  $m$ . Then  $m$  is a divisor of  $m$  and  $P$  is a divisor of  $n$ , but we'll prove that  $m + P$  and  $mn$  are relatively prime.

**4 points.**

Let  $p$  be any prime divisor of  $mn$ .

If  $p$  divides  $m$ , then  $p$  doesn't divide  $P$  and therefore  $p$  doesn't divide  $m + P$ .

**3 points.**

If  $p$  doesn't divide  $m$ , then  $p$  divides  $n$ , and then  $p$  divides  $P$  by definition of  $P$ , which implies that  $p$  doesn't divide  $m + P$ .

**3 points.**

Hence,  $m + P$  and  $mn$  have no common prime factors, which implies they are relatively prime. Hence, there are no solutions.

**Second Solution.** We will prove that there are no solutions. Assume for the sake of contradiction that  $(m, n)$  was a solution. We will recursively construct an infinite unbounded sequence of pairs of positive integers  $(x_k, y_k)_{k \in \mathbb{N}}$  such that  $x_k \mid m$ ,  $y_k \mid n$  and  $M(x_k, y_k) = 1$ .

**1 point.**

Then either  $(x_k)_{k \in \mathbb{N}}$  or  $(y_k)_{k \in \mathbb{N}}$  will be unbounded, but  $x_k \leq m$  and  $y_k \leq n$  for all  $k \in \mathbb{N}$ , which will yield a contradiction.

**1 point.**

Let  $(x_1, y_1) = (1, 1)$ . Let  $k \in \mathbb{N}$ . Suppose we have constructed  $(x_k, y_k)$  satisfying all of the above conditions. Then since  $(m, n)$  is a solution, there exists a prime divisor  $p$  of both  $mn$  and  $x_k + y_k$ .

**1 point.**

If  $p$  divides  $m$ , then let  $(x_{k+1}, y_{k+1}) = (px_k, y_k)$ .

**2 points.**

If  $p$  divides  $n$  and doesn't divide  $m$ , let  $(x_{k+1}, y_{k+1}) = (x_k, py_k)$ .

**2 points.**

In both cases  $x_{k+1}$  divides  $m$  and  $y_{k+1}$  divides  $n$ .

**1 point.**

Also,  $M(x_{k+1}, y_{k+1}) = 1$  because  $p$  does not divide neither  $x_k$  nor  $y_k$  (as  $x_k$  and  $y_k$  are relatively prime and  $p$  divides  $x_k + y_k$ ). Hence, the construction is valid.

**2 points.**

**Notes on marking:**

- In the First solution, there are different choices for pairs of divisors whose sum is relatively prime with  $mn$ . For example, one can take  $(\text{rad}(m), \frac{\text{rad}(mn)}{\text{rad}(m)})$ , where  $\text{rad}(x)$  denotes the product of all prime divisors of  $x$ . If a student finds such a pair and claims that it is a solution without proving that their sum is relatively prime with  $mn$ , and if the proof is as straightforward as in the official solution, he should still get **4 points** from the first part of the solution.

**Problem 2.** Let  $n$  be a positive integer. An  $n \times n$  board consisting of  $n^2$  cells, each being a unit square coloured either black or white, is called *convex* if for every black coloured cell, both the cell directly to the left of it and the cell directly above it are also coloured black. We define the *beauty* of a board as the number of pairs of its cells  $(u, v)$  such that  $u$  is black,  $v$  is white and  $u$  and  $v$  are in the same row or column. Determine the maximum possible beauty of a convex  $n \times n$  board.

(Ivan Novak)

**First Solution.** We colour the board so that in the  $i$ -th row, the leftmost  $n + 1 - i$  cells are black. We'll call this board *the Unicorn*.

**1 point.**

The beauty of this board equals

$$2 \sum_{k=1}^{n-1} k(n-k) = 2 \left( \sum_{k=1}^{n-1} nk - \sum_{k=1}^{n-1} k^2 \right) = 2 \left( \frac{n^2(n-1)}{2} - \frac{n(n-1)(2n-1)}{6} \right) = \frac{n^3 - n}{3}.$$

**1 point.**

We'll call any pair  $(u, v)$  such that  $u$  is white,  $v$  is black and  $u$  and  $v$  are in the same row or column a pretty pair. Now we will prove that the beauty of every convex board is less than or equal to the beauty of the Unicorn. We will do this by performing an algorithm which turns an arbitrary board into the Unicorn in finitely many steps.

Consider an arbitrary convex board. Let  $a_i$  be the number of black coloured cells in the  $i$ -th row. We perform the following algorithm:

If the board is equal to the Unicorn, we are done. Otherwise, find the first row in which  $a_i \neq n + 1 - i$ . Then, we consider two cases:

1.  $a_i < n + 1 - i$ . We colour the  $a_i + 1$ -th cell in the  $i$ -th row black.

**1 point.**

We claim that the beauty of the board didn't decrease.

We now count the number of black/white cells which are in the same row or column as the cell we colored and which are distinct from it.

The number of black cells in the same row is equal to  $a_i$ , and the number of black cells in the same column is  $i - 1$ . On the other hand, the number of white cells in the same row is  $n - 1 - a_i$  and the number of white cells in the same column is  $n - i$ .

**1 point.**

Therefore, the difference of beauties of the board before and after coloring the  $a_i + 1$ -th cell of  $i$ -th row black is  $a_i + (i - 1) - (n - 1 - a_i) - (n - i) = 2(a_i + i - n) \leq 0$ , which implies that the new board's beauty is not smaller.

**1 point.**

2.  $a_i > n + 1 - i$ . Let  $j \geq i$  be the biggest index such that  $a_j = a_i$ . We colour the  $a_i$ -th cell of the  $j$ -th column white.

**1 point.**

We claim that the beauty of the board didn't decrease.

As in the first case, we count the number of black/white cells which are in the same row or column as the cell we colored and which are distinct from it.

The number of white cells in the same row equals  $n - a_j$ , and the number of white cells in the same column equals  $n - j$ . On the other hand, the number of black cells in the same row equals  $a_j - 1$ , and the number of black cells in the same column equals  $j - 1$ .

**1 point.**

Therefore, the difference of beauties of the board before and after coloring the  $a_j$ -th cell of  $j$ -th row white is  $(n - a_j) + (n - j) - (a_j - 1) - (j - 1) = 2(n + 1 - j - a_j) \leq 2(n + 1 - i - a_i) < 0$ , which implies that the new board's beauty is bigger.

**1 point.**

The algorithm terminates because after each step, the number of positions where the board differs from the Unicorn decreases by 1. Therefore, the maximum beauty is achieved for the Unicorn.

**1+1 points.**

**Second Solution.** Consider an arbitrary convex board. Let  $a_i$  denote the number of black cells in the  $i$ -th row. Furthermore, we define  $a_0 = n$  and  $a_{n+1} = 0$ . Then the number of pretty pairs  $(u, v)$  such that  $u$  and  $v$  are in the same row equals

$$\sum_{i=1}^n a_i(n - a_i).$$

**1 point.**

The number of columns with at least  $i$  black cells equals  $a_i$ .

**1 point.**

This implies that the number of columns with exactly  $i$  black cells equals the difference between the number of columns with at least  $i$  black cells and the number of columns with at least  $i + 1$  black cells. Therefore, the number of columns with exactly  $i$  black cells equals  $a_i - a_{i+1}$ .

**2 points.**

This implies that the number of pretty pairs  $(u, v)$  such that  $u$  and  $v$  are in the same column equals

$$\sum_{i=1}^n (a_i - a_{i+1})i(n - i).$$

**1 point.**

Therefore, the beauty of the board equals

$$\sum_{i=1}^n a_i(n - a_i) + (a_i - a_{i+1})i(n - i) = \sum_{i=1}^n a_i(n - a_i + i(n - i) - (i - 1)(n + 1 - i)) = \sum_{i=1}^n a_i(2n + 1 - 2i - a_i).$$

**1 point.**

For a fixed  $i \in \{1, \dots, n\}$ ,  $a_i(2n + 1 - 2i - a_i)$  is a quadratic function of  $a_i$ , which is increasing for  $a_i \in [0, n - i + \frac{1}{2}]$  and decreasing for  $a_i \in [n - i + \frac{1}{2}, n]$ , and the maximum among all integer  $a_i$  is then achieved if  $a_i \in \{n - i, n - i + 1\}$ .

**1 point.**

Therefore, the whole sum is maximised if  $a_i \in \{n - i, n - i + 1\}$  for all  $i \in \{1, \dots, n\}$ .

**1 point.**

Any board with  $a_i \in \{n - i, n - i + 1\}$  is convex since then  $a_i \geq a_{i+1}$  for any of the possible choices.

**1 point.**

In this case, the sum equals

$$\sum_{i=1}^n (n - i)(n - i + 1) = \sum_{i=1}^n i(i - 1) = \sum_{i=1}^n i^2 - i = \frac{n(n + 1)(2n + 1) - 3n(n + 1)}{6} = \frac{n^3 - n}{6}.$$

**1 point.**

**Notes on marking:**

- A student is awarded the maximum of the two scores he gets by following either of the two marking schemes. Points from different solutions are not additive.
- If the student produces an optimal board, writes down its beauty, but does not simplify the expression to a closed form, then:
  - a) if the student does not prove the optimality of the board (a “0+” solution), he is awarded **0 points** for this part;
  - b) if the student proves the optimality of the board (a “10-” solution), he is awarded **1 point** for this part.
- In the **First Solution**, the last **2 points** are only awarded if he gives a correct algorithm.
- In the **First Solution**, if the student has a correct algorithm, but fails to prove that it terminates, he should be deducted **1 point**.
- In the **Second Solution**, the “other direction” is implicit in the last part of the solution. This is because the Unicorn configuration is covered by the given equality cases. If the student gives an optimal board as in the other solutions, and then shows that his optimal board is contained in the equality case, his solution is complete. However, if the student does not in any way show that his lower and upper bounds match, he should be deducted **1 point**.

**Problem 3.** In an acute triangle  $ABC$  with  $|AB| \neq |AC|$ , let  $I$  be the incenter and  $O$  the circumcenter. The incircle is tangent to  $\overline{BC}$ ,  $\overline{CA}$  and  $\overline{AB}$  in  $D$ ,  $E$  and  $F$  respectively. Prove that if the line parallel to  $EF$  passing through  $I$ , the line parallel to  $AO$  passing through  $D$  and the altitude from  $A$  are concurrent, then the point of concurrence is the orthocenter of the triangle  $ABC$ .

(Petar Nizić-Nikolac)

Sketch.

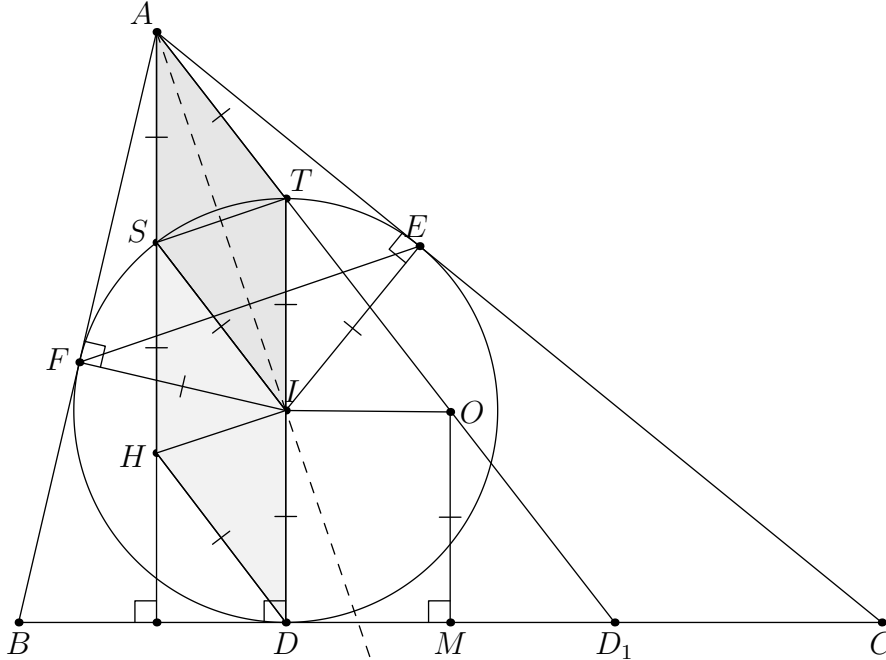

**Solution.** Let  $H$  be that concurrence point. We shall prove that  $H$  is the orthocenter of the triangle  $ABC$ . Firstly we observe that  $AFIE$  is a deltoid (because  $|AE| = |AF|$  and  $|IE| = |IF|$ ), so  $AI \perp EF \parallel HI$ .

1 point.

Using the fact that  $AI$  is the bisector of  $\angle OAH$  and  $AH \parallel ID$  we conclude that

$$\angle DIH = \angle AID - 90^\circ = 180^\circ - \angle IAH - 90^\circ = 90^\circ - \frac{\angle OAH}{2} = 90^\circ - \frac{\angle HDI}{2}$$

so triangle  $IHD$  is an isoscales one.

1 point.

Denote by  $T$  the second intersection of the line  $DI$  and the incircle and  $S$  as the point such that  $SHDI$  is a rhombus. It follows that  $S$  lies on  $AH$ , but also that triangle  $ISH$  is an isoscales one, so

$$\angle SIA = 90^\circ - \angle SIH = 90^\circ - \angle SHI = 90^\circ - \angle HID = \angle AIT = \angle IAS.$$

Hence  $|AS| = |SI| = |ID| = |IT|$  (we used that  $I$  is the midpoint of  $\overline{TD}$ ), so  $ASIT$  is a rhombus.

3 points.

*Lemma.*  $A, T, O$  and  $D_1$  are collinear, where  $D_1$  is the point where  $A$ -excircle is tangent to  $BC$ .

*Proof.* Firstly,  $A, T$  and  $O$  are collinear as  $AT \parallel SI \parallel HD \parallel AO$ .

1 point.

Secondly,  $A, T$  and  $D_1$  are collinear as there is homothety from  $A$  sending incircle to  $A$ -excircle, so the "highest" points (w.r.t.  $\overline{BC}$ ) of these circles ( $T$  and  $D_1$ ) and the center of homothety ( $A$ ) are collinear. Therefore,  $A, T, O$  and  $D_1$  are collinear.  $\square$

1 point.

Denote by  $M$  the midpoint of  $\overline{BC}$ . We know that  $|BD| = \frac{|AB|+|BC|-|AC|}{2} = |CD_1|$ , so  $M$  is the midpoint of  $\overline{DD_1}$ .

1 point.

As  $TDD_1$  is a right triangle and  $\angle OMD_1 = 90^\circ$  we conclude that  $\overline{OM}$  is a  $D_1$ -midline in the triangle  $TDD_1$ , hence

$$2|OM| = |TD| = |TI| + |ID| = |AS| + |SH| = |AH|.$$

1 point.

Now we can conclude in various ways (for example, using the Euler line argument) that  $H$  is the orthocenter of the triangle  $ABC$ .

1 point.

**Notes on marking:**

- Essentially, **5 points** are awarded for proving that  $AHDT$  is a parallelogram with longer side being twice the size of the shorter side, next **4 points** are awarded for proving that  $2|OM| = |AH|$  is true, and **1 point** is awarded for deduction that  $H$  is indeed an orthocenter.
- If a student states that  $A, T, D_1$  are collinear in a general triangle without using it to prove the problem (for example, by introducing the point  $O$  and stating that it should be on the line), it should be awarded **0 points**. On the other hand, if a student uses this fact to prove the problem, it does not have to prove this fact and it is enough to state it. In that case it is awarded **1 point**.
- If a student states that  $2|OM| = |AH|$  in a general triangle without using it to prove the problem (for example, by noting that  $|OM| = |ID|$ ), it should be awarded **0 points**. On the other hand, if a student uses this fact to prove the problem, it does not have to prove this fact and it is enough to state it. In that case it is awarded **1 point**.
- If a student has a partial solution with analytic methods, only points for proving facts that can be expressed in geometric ways and lead to a complete solution can be awarded.

**Problem 4.** Find all functions  $f : \mathbb{R} \rightarrow \mathbb{R}$  such that

$$f(x) + f(yf(x) + f(y)) = f(x + 2f(y)) + xy$$

for all  $x, y \in \mathbb{R}$ .

(Adrian Beker)

**Solution.** It is easily checked that  $f(x) = x + 1$  is a valid solution. We will prove that it is the only solution. Let  $P(x, y)$  denote the assertion

$$f(x) + f(yf(x) + f(y)) = f(x + 2f(y)) + xy$$

and let  $a = f(0)$ . We will first prove the following claim:

*Claim.*  $f$  is injective

*Proof:* Suppose that  $f(x) = f(y) = t$  for some  $x, y \in \mathbb{R}$ . We have:

$$P(x, x) \implies t + f(xt + t) = f(x + 2t) + x^2$$

$$P(x, y) \implies t + f(yt + t) = f(x + 2t) + xy$$

Subtracting the last two equations yields  $f(xt + t) - f(yt + t) = x(x - y)$ . Similarly, we have  $f(yt + t) - f(xt + t) = y(y - x)$  which implies  $(x - y)^2 = 0 \implies x = y$ , hence  $f$  is injective.  $\square$

**4 points.**

We have:

$$P(x, 0) \implies f(x) + f(a) = f(x + 2a) \tag{1}$$

Setting  $x = -a$  yields  $f(-a) = 0$ . Now we have:

$$P(x, -a) \implies f(-af(x)) = -ax \tag{2}$$

Again, setting  $x = -a$  yields  $a = a^2$ , hence  $a \in \{0, 1\}$ .

**1 point.**

**Case 1.**  $a = 0$

$$P(0, y) \implies f(f(y)) = f(2f(y))$$

Since  $f$  is injective, we have  $f(y) = 2f(y) \implies f(y) = 0$  for all  $y \in \mathbb{R}$ , which is clearly impossible.

**1 point.**

**Case 2.**  $a = 1$

Now (2) implies  $f(-f(x)) = -x$  for all  $x \in \mathbb{R}$ . This means that  $f$  is bijective. On the other hand, (1) implies that  $f(x) + f(1) = f(x + 2)$  for all  $x \in \mathbb{R}$ .

$$P(x + 2, y) \implies f(x + 2) + f(yf(x + 2) + f(y)) = f(x + 2 + 2f(y)) + (x + 2)y$$

$$f(x) + f(y) + f(yf(x) + f(y)) + yf(1) = f(x + 2f(y)) + f(1) + xy + 2y$$

**1 point.**

By subtracting the initial equation from this one, we obtain:

$$f(yf(x) + f(y)) + yf(1) = f(yf(x) + f(y)) + 2y$$

If  $y \neq 0$ , we can choose  $x \in \mathbb{R}$  such that  $f(x) = -\frac{f(y)}{y}$  because  $f$  is surjective, hence the last equation yields:

$$f(yf(1)) = 2y + 1$$

**2 points.**

for all  $y \neq 0$ , but it is also true for  $y = 0$ . In particular, setting  $y = -\frac{1}{2}$  yields  $f(-\frac{f(1)}{2}) = 0$ . Since  $f$  is injective and  $f(-1) = 0$ , it follows that  $f(1) = 2 \implies f(2y) = 2y + 1$  for all  $y \in \mathbb{R}$ . Finally, we deduce that  $f(x) = x + 1$  for all  $x \in \mathbb{R}$ , as desired.  $\square$

**1 point.**

**Notes on marking:**

- The case  $a = 1$  can be finished without injectivity. If a student deduces that  $f$  is linear and checks that the only option for  $f$  is  $f(x) = x + 1$ , he should get **1 point**.
- If a student manages to prove that  $f$  is injective in the case  $a = 0$ , he should get **4 points** from the first part of the solution since in the case  $a = 1$  the proof can be finished without injectivity.
- If a student doesn't check that  $f(x) = x + 1$  is indeed a solution or at least mention that it can be easily checked, he should lose **1 point**.

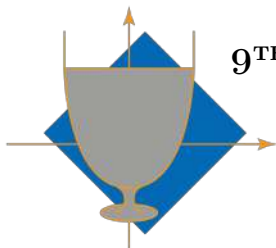

**9<sup>TH</sup> EUROPEAN MATHEMATICAL CUP**  
12<sup>th</sup> December 2020 - 20<sup>th</sup> December 2020  
Junior Category



**Problem 1.** Let  $ABC$  be an acute-angled triangle. Let  $D$  and  $E$  be the midpoints of sides  $\overline{AB}$  and  $\overline{AC}$  respectively. Let  $F$  be the point such that  $D$  is the midpoint of  $\overline{EF}$ . Let  $\Gamma$  be the circumcircle of triangle  $FDB$ . Let  $G$  be a point on the segment  $\overline{CD}$  such that the midpoint of  $\overline{BG}$  lies on  $\Gamma$ . Let  $H$  be the second intersection of  $\Gamma$  and  $FC$ . Show that the quadrilateral  $BHGC$  is cyclic.

(Art Waeterschoot)

**Problem 2.** A positive integer  $k \geq 3$  is called *fibby* if there exists a positive integer  $n$  and positive integers  $d_1 < d_2 < \dots < d_k$  with the following properties:

- $d_{j+2} = d_{j+1} + d_j$  for every  $j$  satisfying  $1 \leq j \leq k - 2$ ,
- $d_1, d_2, \dots, d_k$  are divisors of  $n$ ,
- any other divisor of  $n$  is either less than  $d_1$  or greater than  $d_k$ .

Find all fibby numbers.

(Ivan Novak)

**Problem 3.** Two types of tiles, depicted on the figure below, are given.

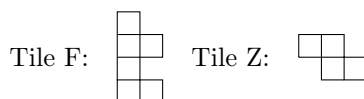

Find all positive integers  $n$  such that an  $n \times n$  board consisting of  $n^2$  unit squares can be covered without gaps with these two types of tiles (rotations and reflections are allowed) so that no two tiles overlap and no part of any tile covers an area outside the  $n \times n$  board.

(Art Waeterschoot)

**Problem 4.** Let  $a, b, c$  be positive real numbers such that  $ab + bc + ac = a + b + c$ . Prove the following inequality:

$$\sqrt{a + \frac{b}{c}} + \sqrt{b + \frac{c}{a}} + \sqrt{c + \frac{a}{b}} \leq \sqrt{2} \cdot \min \left\{ \frac{a}{b} + \frac{b}{c} + \frac{c}{a}, \frac{b}{a} + \frac{c}{b} + \frac{a}{c} \right\}.$$

(Dorlir Ahmeti)

Time: 240 minutes.

Each problem is worth 10 points.

The use of calculators or any other instruments except rulers and compasses is not permitted.

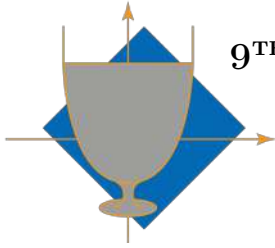

## Problems and Solutions

**Problem 1.** Let  $ABC$  be an acute-angled triangle. Let  $D$  and  $E$  be the midpoints of sides  $\overline{AB}$  and  $\overline{AC}$  respectively. Let  $F$  be the point such that  $D$  is the midpoint of  $\overline{EF}$ . Let  $\Gamma$  be the circumcircle of triangle  $FDB$ . Let  $G$  be a point on the segment  $\overline{CD}$  such that the midpoint of  $\overline{BG}$  lies on  $\Gamma$ . Let  $H$  be the second intersection of  $\Gamma$  and  $\overline{FC}$ . Show that the quadrilateral  $BHGC$  is cyclic.

(Art Waeterschoot, Belgium)

Sketch for the First Solution.

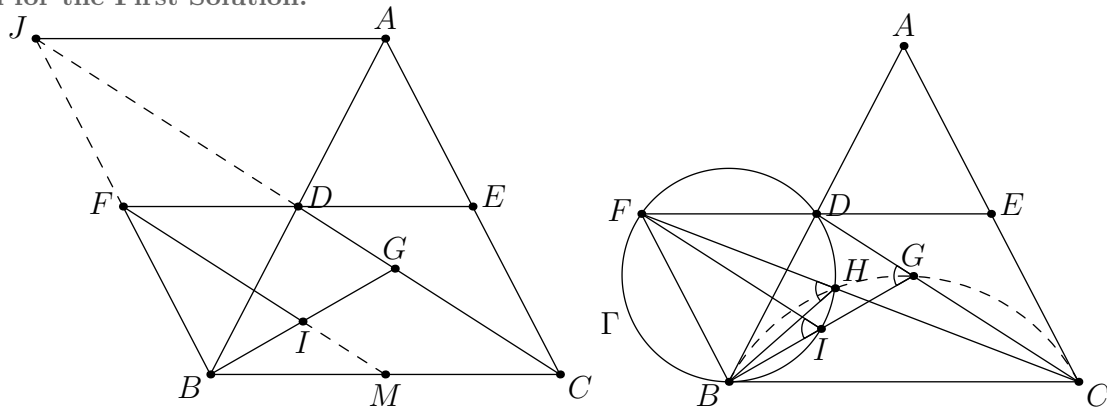

**First Solution.** Since  $D$  and  $E$  are midpoints, the diagonals  $\overline{AB}$  and  $\overline{EF}$  of the quadrilateral  $AFBE$  bisect each other, so  $AFBE$  is a parallelogram. Hence  $BF \parallel AE$ .

2 points.

**Lemma.** If  $I$  is the second intersection of  $\Gamma$  and  $\overline{BG}$ , then  $FI \parallel CD$ . (We will present two different proofs.)

**First proof.** Let  $J$  be the point such that  $BCAJ$  is a parallelogram. Since  $BF \parallel AE$ , we have that  $B, F, J$  are collinear.

2 points.

Since  $D$  is the midpoint of  $\overline{AB}$ ,  $C, D, J$  are collinear.

1 point.

As  $F$  and  $I$  are midpoints of  $\overline{BJ}$  and  $\overline{BG}$ , then  $FI \parallel CD$ .  
 $\square$

2 points.

Now as we know that  $FI \parallel CD$ , we have  $\angle BIF = \angle BGD$ .

1 point.

As  $BIHF$  is a cyclic quadrilateral, we have  $\angle BIF = \angle BHF$ .

1 point.

Hence

$$\angle CHB = 180^\circ - \angle BHF = 180^\circ - \angle BGD = \angle CGB,$$

so  $BHGC$  is cyclic as desired.

1 point.

1 point.

Sketch for the Second Solution.

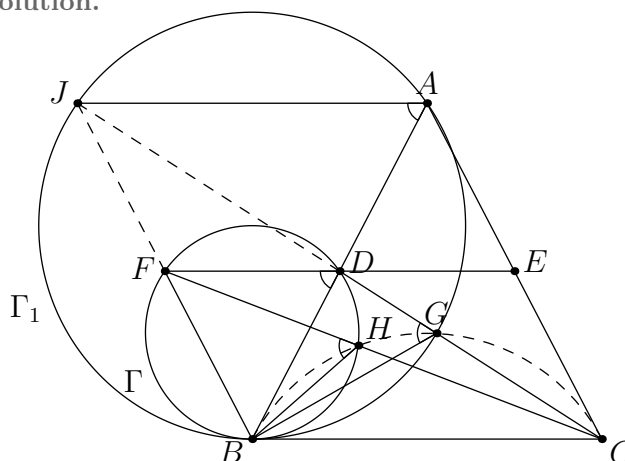

**Second Solution.** Since  $D$  and  $E$  are midpoints, the diagonals  $\overline{AB}$  and  $\overline{EF}$  of the quadrilateral  $AFBE$  bisect each other, so  $AFBE$  is a parallelogram. Hence  $BF \parallel AE$ .

2 points.

Let  $J$  be the point such that  $BCAJ$  is a parallelogram. Since  $BF \parallel AE$ , we have that  $B, F, J$  are collinear.

2 points.

Since  $D$  is the midpoint of  $\overline{AB}$ ,  $C, D, J$  are collinear.

1 point.

Now let  $\Gamma_1$  be the circumcircle of triangle  $JAB$ . As  $F$  and  $D$  are midpoints of  $\overline{BJ}$  and  $\overline{BA}$ , and the midpoint of  $\overline{BG}$  lies on  $\Gamma$ , we can redefine  $G$  as the second intersection of  $\Gamma_1$  and  $CJ$ .

2 points.

As  $AJBG$  is a cyclic quadrilateral, we have  $\angle BGJ = \angle BAJ$ .

1 point.

As  $FD$  is parallel to  $JA$ , we have  $\angle BAJ = \angle BDF$ .

0 points.

As  $BHDF$  is a cyclic quadrilateral, we have  $\angle BDF = \angle BHF$ .

1 point.

Hence

$$\angle CHB = 180^\circ - \angle BHF = 180^\circ - \angle BGD = \angle CGB,$$

so  $BHGC$  is cyclic as desired.

1 point.

**Notes on marking:**

- If a student has a partial solution with analytic methods, only points for proving facts that can be expressed in geometric ways and lead to a complete solution can be awarded.

**Problem 2.** A positive integer  $k \geq 3$  is called *fibby* if there exists a positive integer  $n$  and positive integers  $d_1 < d_2 < \dots < d_k$  with the following properties:

- $d_{j+2} = d_{j+1} + d_j$  for every  $j$  satisfying  $1 \leq j \leq k - 2$ ,
- $d_1, d_2, \dots, d_k$  are divisors of  $n$ ,
- any other divisor of  $n$  is either less than  $d_1$  or greater than  $d_k$ .

Find all fibby numbers.

*(Ivan Novak)*

**Solution.** Note that  $(1, 2, 3, 5)$  is a sequence of length 4 such that all its elements are divisors of 30 and every other divisor of 30 is either less than 1 or greater than 5. Also  $3 = 1 + 2$  and  $5 = 2 + 3$ , which means 4 is fibby. Consequently, 3 is also fibby.

**1 point.**

Suppose there exist positive integers  $n, d_1 < d_2 < \dots < d_k$  satisfying the problem's conditions, with  $k \geq 5$ . Suppose for the sake of contradiction that  $d_j$  is even for some  $j \geq 3$ . Then  $\frac{d_j}{2}$  is also a divisor of  $n$ .

**1 point.**

However,

$$d_1 \leq d_{j-2} < \frac{d_{j-1} + d_{j-2}}{2} = \frac{d_j}{2} < d_{j-1} < d_k.$$

This implies  $\frac{d_j}{2}$  is a divisor of  $n$  which is neither less than  $d_1$  nor greater than  $d_k$  and is distinct from the numbers  $d_1, d_2, \dots, d_k$ , which is a contradiction.

**6 points.**

This implies that  $d_3$  and  $d_4$  are odd. However, this means that  $d_5 = d_3 + d_4$  is even, which is a contradiction. Therefore, any number greater than 4 is not fibby.

**2 points.**

**Notes on marking:**

- The part of the proof where we prove all  $k \geq 5$  are not fibby is worth **9 points**. It may happen that a contestant proves a weaker statement in that direction.
  - If a contestant proves that there exists  $C$  such that no  $k \geq C$  is fibby, they should get **1 point**.
  - If the  $C$  above is explicit, they should get an additional **1 point**.
  - If in addition  $C = 6$ , they should get **1 point** more.

The points above (at most **3 points**) are not additive with the points for proving  $C = 5$  in the official solution. Thus, without using ideas that can solve the  $C = 5$  case, the contestant should not get more than **1 point** for the construction, plus the points above if applicable.

- Many solutions proceed by cases on the parity of  $d_1$  and  $d_2$ . However, in all solutions that the Problem Selection Committee were aware of, the only parity that matters is the parity of some  $d_j, j \geq 3$ .

Thus, stating and proving that some of  $d_3, d_4$  and  $d_5$  is even is worth **2 points**, as in the official solution, and no other points are awarded for parity concerns.

**Problem 3.** Two types of tiles, depicted on the figure below, are given.

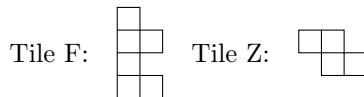

Find all positive integers  $n$  such that an  $n \times n$  board consisting of  $n^2$  unit squares can be covered without gaps with these two types of tiles (rotations and reflections are allowed) so that no two tiles overlap and no part of any tile covers an area outside the  $n \times n$  board.

(Art Waeterschoot)

**Solution.** We claim such a tiling exists whenever  $n$  is divisible by 4 and greater than 4.

**0 points.**

We now prove the existence of a tiling in the case where  $n$  is divisible by 4 and greater than 4. The figure below shows that if  $k \geq 1$ , we can tile a  $(2k + 1) \times 4$ -rectangle.

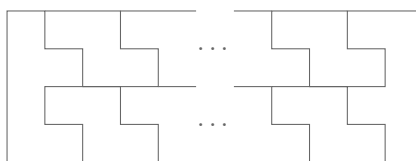

**1 point.**

By gluing a  $3 \times 4$  rectangle to the above tiling, we get a tiling of any  $(4k + 4) \times 4$  rectangle, where  $k \geq 1$ . We can now stack  $k + 1$  such rectangles next to each other to obtain a  $(4k + 4) \times (4k + 4)$  square, which proves the claim.

**1 point.**

Suppose we can tile a  $n \times n$  square with the given tiles. Let  $a$  and  $b$  be the number of  $F$ -tiles and  $Z$ -tiles used in the tiling, respectively. Then  $6a + 4b = n^2$ , which implies  $n$  is even. This implies that  $a$  is also even. Let  $n = 2k$ , where  $k$  is a positive integer.

**0 points.**

Consider the following colouring of the square: divide up the square into  $k^2$  smaller squares of size  $2 \times 2$  and colour these squares with a chessboard colouring (see the figure below). Every  $F$ -tile covers exactly 3 black unit squares and every  $Z$ -tile covers an odd number of black unit squares.

**1 point.**

Because there are an even number of black squares, we obtain that  $a$  and  $b$  have equal parity. Since  $a$  is even, this implies that  $b$  is even.

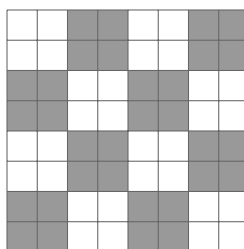

**3 points.**

Now colour all unit squares in an even row and odd column black (see the figure below). Now every  $F$ -tile covers an even number of black unit squares and every  $Z$ -tile covers exactly one black unit square.

**1 point.**

Since the number of black squares is  $k^2$ , we obtain that  $b$  and  $k^2$  have equal parity. Since  $b$  is even, this implies  $k$  is even.

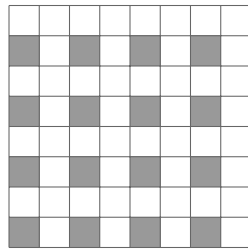

**3 points.**

Therefore,  $n$  is a multiple of 4.

**0 points.**

Furthermore, it is easily seen a  $4 \times 4$ -square cannot be tiled, as there are no positive integers  $(a, b)$  such that  $b$  is even and  $6a + 4b = 16$ .

**0 points.**

**Notes on marking:**

- Colouring a square in a certain way without drawing any relevant conclusions from the colouring is worth **0 points**.
- Another possible solution is to consider a colouring with 4 colours by dividing up into small  $2 \times 2$ -squares. In fact this is equivalent to our solution, because is the same as considering both colourings above at once. Considering such a colouring and drawing the same conclusions is worth the same amount of points as considering the colourings one by one.
- If a student doesn't check the case when  $n = 4$ , they can score at most **9 points** on the problem.
- The standard chessboard colouring gives only that  $a$  is even, which is considered trivial by the Jury, thus it is worth **0 points**.
- If a student has another colouring which proves that  $2|b$ , this is worth **4 points**, as in the official solution.
- If a student has another colouring which proves that  $4|a$ , this is worth **4 points**, as in the official solution.

**Problem 4.** Let  $a, b, c$  be positive real numbers such that  $ab+bc+ac = a+b+c$ . Prove the following inequality:

$$\sqrt{a + \frac{b}{c}} + \sqrt{b + \frac{c}{a}} + \sqrt{c + \frac{a}{b}} \leq \sqrt{2} \cdot \min \left\{ \frac{a}{b} + \frac{b}{c} + \frac{c}{a}, \frac{b}{a} + \frac{c}{b} + \frac{a}{c} \right\}.$$

(Dorlir Ahmeti)

**First Solution.** We can rewrite the inequality as

$$\sum_{cyc} 2\sqrt{2\left(a + \frac{b}{c}\right)} \leq 4 \cdot \min \left\{ \frac{a}{b} + \frac{b}{c} + \frac{c}{a}, \frac{b}{a} + \frac{c}{b} + \frac{a}{c} \right\}$$

and distinguish two cases based on what the right hand side is.

**Case 1.**  $\min \left\{ \frac{a}{b} + \frac{b}{c} + \frac{c}{a}, \frac{b}{a} + \frac{c}{b} + \frac{a}{c} \right\} = \frac{a}{b} + \frac{b}{c} + \frac{c}{a}.$

Using *AM-GM* inequality, we have

$$\sum_{cyc} 2\sqrt{2\left(a + \frac{b}{c}\right)} \leq \sum_{cyc} \left(2 + a + \frac{b}{c}\right) = 6 + a + b + c + \frac{a}{b} + \frac{b}{c} + \frac{c}{a}.$$

**2 points.**

Hence, it is enough to prove

$$\begin{aligned} 6 + a + b + c + \frac{a}{b} + \frac{b}{c} + \frac{c}{a} &\leq 4 \left( \frac{a}{b} + \frac{b}{c} + \frac{c}{a} \right) \\ \iff 6 + a + b + c &\leq 3 \left( \frac{a}{b} + \frac{b}{c} + \frac{c}{a} \right). \end{aligned} \tag{1}$$

Applying *AM-GM* inequality we obtain

$$2 \left( \frac{a}{b} + \frac{b}{c} + \frac{c}{a} \right) \geq 2 \cdot 3 \sqrt[3]{\frac{a}{b} \cdot \frac{b}{c} \cdot \frac{c}{a}} = 6 \tag{2}$$

and using *Cauchy-Schwarz* inequality together with the condition allows us to conclude:

$$\begin{aligned} (ab + bc + ac) \left( \frac{a}{b} + \frac{b}{c} + \frac{c}{a} \right) &\geq (a + b + c)^2 = (a + b + c)(ab + bc + ac) \\ \implies \frac{a}{b} + \frac{b}{c} + \frac{c}{a} &\geq a + b + c. \end{aligned} \tag{3}$$

**2 points.**

Combining results (2) and (3) yields (1).

**Case 2.**  $\min \left\{ \frac{a}{b} + \frac{b}{c} + \frac{c}{a}, \frac{b}{a} + \frac{c}{b} + \frac{a}{c} \right\} = \frac{b}{a} + \frac{c}{b} + \frac{a}{c}.$

Using *AM-GM* inequality, we have

$$\sum_{cyc} 2\sqrt{2\left(a + \frac{b}{c}\right)} = \sum_{cyc} 2\sqrt{\frac{2a}{c} \left(c + \frac{b}{a}\right)} \leq \sum_{cyc} \left(\frac{2a}{c} + c + \frac{b}{a}\right) = a + b + c + 3 \left(\frac{b}{a} + \frac{c}{b} + \frac{a}{c}\right).$$

**4 points.**

Hence, it is enough to prove

$$\begin{aligned} a + b + c + 3 \left( \frac{b}{a} + \frac{c}{b} + \frac{a}{c} \right) &\leq 4 \left( \frac{b}{a} + \frac{c}{b} + \frac{a}{c} \right) \\ \iff a + b + c &\leq \frac{b}{a} + \frac{c}{b} + \frac{a}{c}. \end{aligned}$$

Using *Cauchy-Schwarz* inequality together with the condition allows us to conclude

$$\begin{aligned} (ab + bc + ac) \left( \frac{b}{a} + \frac{c}{b} + \frac{a}{c} \right) &\geq (a + b + c)^2 = (a + b + c)(ab + bc + ac) \\ \implies \frac{b}{a} + \frac{c}{b} + \frac{a}{c} &\geq a + b + c \end{aligned}$$

**2 points.**

which is exactly what we wanted to prove.

**Second Solution.** Using the substitution  $m = \min \left\{ \frac{a}{b} + \frac{b}{c} + \frac{c}{a}, \frac{b}{a} + \frac{c}{b} + \frac{a}{c} \right\}$ , we can rewrite the inequality as

$$\frac{1}{3} \left( \sqrt{a + \frac{b}{c}} + \sqrt{b + \frac{c}{a}} + \sqrt{c + \frac{a}{b}} \right) \leq \frac{m\sqrt{2}}{3}.$$

Recognizing the left hand side as an arithmetic mean, we may apply the *QM-AM* inequality to obtain

$$\frac{1}{3} \left( \sqrt{a + \frac{b}{c}} + \sqrt{b + \frac{c}{a}} + \sqrt{c + \frac{a}{b}} \right) \leq \sqrt{\frac{a + \frac{b}{c} + b + \frac{c}{a} + c + \frac{a}{b}}{3}}.$$

We're now left with proving

$$\frac{a + \frac{b}{c} + b + \frac{c}{a} + c + \frac{a}{b}}{3} \leq \left( \frac{m\sqrt{2}}{3} \right)^2$$

which can be written as:

$$\frac{3}{2}(a + b + c) + \frac{3}{2} \left( \frac{a}{b} + \frac{b}{c} + \frac{c}{a} \right) \leq m^2. \quad (1)$$

**1 point.**

We distinguish two cases based on the value of  $m$ :

**Case 1.**  $m = \frac{b}{a} + \frac{c}{b} + \frac{a}{c}$ .

Expanding the right hand side of (1) and cancelling out  $\frac{3}{2} \left( \frac{a}{b} + \frac{b}{c} + \frac{c}{a} \right)$  turns the inequality into

$$\frac{3}{2}(a + b + c) \leq \frac{b^2}{a^2} + \frac{c^2}{b^2} + \frac{a^2}{c^2} + \frac{1}{2} \left( \frac{a}{b} + \frac{b}{c} + \frac{c}{a} \right).$$

Multiplying both sides by  $2(ab + bc + ac)$  and making use of the given condition on the left hand side gives us:

$$3(a + b + c)^2 \leq 2 \left( \frac{b^2}{a^2} + \frac{c^2}{b^2} + \frac{a^2}{c^2} \right) (ab + bc + ac) + \left( \frac{a}{b} + \frac{b}{c} + \frac{c}{a} \right) (ab + bc + ac).$$

We may now apply *Cauchy-Schwarz* inequality to obtain  $\left( \frac{a}{b} + \frac{b}{c} + \frac{c}{a} \right) (ab + bc + ac) \geq (a + b + c)^2$

**2 points.**

and this leaves us with proving the following:

$$(a + b + c)^2 \leq \left( \frac{b^2}{a^2} + \frac{c^2}{b^2} + \frac{a^2}{c^2} \right) (ab + bc + ac). \quad (2)$$

We now make use of a well known lemma:

**Lemma 1.** For positive real numbers  $x, y, z$  one has  $\frac{x}{y} + \frac{y}{z} + \frac{z}{x} \geq \frac{x + y + z}{\sqrt[3]{xyz}}$ .

*Proof.* Applying *AM-GM* inequality we obtain:

$$\frac{x}{y} + \frac{x}{y} + \frac{y}{z} \geq 3 \sqrt[3]{\frac{x^2 y}{y^2 z}} = \frac{3x}{\sqrt[3]{xyz}},$$

$$\frac{y}{z} + \frac{y}{z} + \frac{z}{x} \geq 3 \sqrt[3]{\frac{y^2 z}{z^2 x}} = \frac{3y}{\sqrt[3]{xyz}},$$

$$\frac{z}{x} + \frac{z}{x} + \frac{x}{y} \geq 3 \sqrt[3]{\frac{z^2 x}{x^2 y}} = \frac{3z}{\sqrt[3]{xyz}}.$$

Summing up the above three inequalities finishes the proof of the lemma. □

**3 points.**

Applying the lemma we obtain  $\frac{b^2}{a^2} + \frac{c^2}{b^2} + \frac{a^2}{c^2} \geq \frac{a^2 + b^2 + c^2}{\sqrt[3]{a^2 b^2 c^2}}$  and applying *AM-GM* we obtain  $ab + bc + ac \geq 3 \sqrt[3]{a^2 b^2 c^2}$ , which together used in (2) mean that we only need to prove

$$(a + b + c)^2 \leq 3(a^2 + b^2 + c^2)$$

and this is equivalent to  $(a - b)^2 + (b - c)^2 + (a - c)^2 \geq 0$ .

**1 point.**

**Case 2.**  $m = \frac{a}{b} + \frac{b}{c} + \frac{c}{a}$ .

Expanding the right hand side of (1) turns the inequality into

$$\frac{3}{2}(a+b+c) + \frac{3}{2} \left( \frac{a}{b} + \frac{b}{c} + \frac{c}{a} \right) \leq \frac{a^2}{b^2} + \frac{b^2}{c^2} + \frac{c^2}{a^2} + 2 \left( \frac{b}{a} + \frac{c}{b} + \frac{a}{c} \right). \quad (3)$$

Since  $m = \frac{a}{b} + \frac{b}{c} + \frac{c}{a}$ , we have that  $\frac{3}{2} \left( \frac{a}{b} + \frac{b}{c} + \frac{c}{a} \right) \leq \frac{3}{2} \left( \frac{b}{a} + \frac{c}{b} + \frac{a}{c} \right)$  and using this in (3), we're left with proving:

$$\frac{3}{2}(a+b+c) \leq \frac{a^2}{b^2} + \frac{b^2}{c^2} + \frac{c^2}{a^2} + \frac{1}{2} \left( \frac{b}{a} + \frac{c}{b} + \frac{a}{c} \right).$$

**1 point.**

The rest of the proof is now analogous to the steps we used to solve the first case, namely multiplying both sides by  $2(ab+bc+ac)$  and making use of the given condition, applying *Cauchy-Schwarz* inequality to prove  $\left( \frac{b}{a} + \frac{c}{b} + \frac{a}{c} \right) (ab+bc+ac) \geq (a+b+c)^2$ , making use of the lemma to prove  $\frac{a^2}{b^2} + \frac{b^2}{c^2} + \frac{c^2}{a^2} \geq \frac{a^2+b^2+c^2}{\sqrt[3]{a^2b^2c^2}}$ , making use of *AM-GM* inequality to obtain  $ab+bc+ac \geq 3\sqrt[3]{a^2b^2c^2}$  and finally proving  $(a+b+c)^2 \leq 3(a^2+b^2+c^2)$ .

**2 points.**

**Third Solution.** Let  $m = \min \left\{ \frac{a}{b} + \frac{b}{c} + \frac{c}{a}, \frac{b}{a} + \frac{c}{b} + \frac{a}{c} \right\}$  and  $n = \max \left\{ \frac{a}{b} + \frac{b}{c} + \frac{c}{a}, \frac{b}{a} + \frac{c}{b} + \frac{a}{c} \right\}$ .

0 points.

Using *Cauchy-Schwarz* inequality, we obtain the following:

$$\begin{aligned} \sqrt{a + \frac{b}{c}} + \sqrt{b + \frac{c}{a}} + \sqrt{c + \frac{a}{b}} &= \sqrt{\left( \sqrt{\frac{ac+b}{c}} + \sqrt{\frac{ab+c}{a}} + \sqrt{\frac{bc+a}{b}} \right)^2} \\ &\leq \sqrt{(ac+b+ab+c+bc+a) \left( \frac{1}{c} + \frac{1}{a} + \frac{1}{b} \right)} \end{aligned}$$

2 points.

Now by using  $ab+bc+ac = a+b+c$ , we get:

$$\sqrt{(ac+b+ab+c+bc+a) \left( \frac{1}{c} + \frac{1}{a} + \frac{1}{b} \right)} = \sqrt{2(a+b+c) \left( \frac{1}{a} + \frac{1}{b} + \frac{1}{c} \right)}.$$

Therefore, we want to show

$$\sqrt{(a+b+c) \left( \frac{1}{a} + \frac{1}{b} + \frac{1}{c} \right)} \leq m. \quad (1)$$

0 points.

We proceed by proving

$$m^2 \geq 3 + 2n. \quad (2)$$

*Proof.* Using *AM-GM* inequality, we get the following:

$$\frac{b^2}{a^2} + \frac{c^2}{b^2} + \frac{a^2}{c^2} \geq 3.$$

Applying this result, we see that

$$\left( \frac{b}{a} + \frac{c}{b} + \frac{a}{c} \right)^2 = \frac{b^2}{a^2} + \frac{c^2}{b^2} + \frac{a^2}{c^2} + 2 \left( \frac{a}{b} + \frac{b}{c} + \frac{c}{a} \right) \geq 3 + 2 \left( \frac{a}{b} + \frac{b}{c} + \frac{c}{a} \right).$$

Analogously, we also get that  $\left( \frac{a}{b} + \frac{b}{c} + \frac{c}{a} \right)^2 \geq 3 + 2 \left( \frac{b}{a} + \frac{c}{b} + \frac{a}{c} \right)$ , which proves (2).  $\square$

2 points.

Now  $m \leq n$  along with (2) yields

$$\begin{aligned} \sqrt{(a+b+c) \left( \frac{1}{a} + \frac{1}{b} + \frac{1}{c} \right)} &= \sqrt{3 + \left( \frac{a}{b} + \frac{b}{c} + \frac{c}{a} \right) + \left( \frac{b}{a} + \frac{c}{b} + \frac{a}{c} \right)} \\ &= \sqrt{3 + m + n} \\ &\leq \sqrt{3 + 2n} \\ &\leq \sqrt{m^2} = m \end{aligned}$$

which is exactly (1).

6 points.

**Notes on marking:**

- In the third solution, considering only one case for  $m \neq n$  and completing the proof is worth **8 points**. Full points are awarded if the analogy to the other case is mentioned.
- Proving  $\frac{a}{b} + \frac{b}{c} + \frac{c}{a} \geq 3$  should not be awarded any points as this claim is considered trivial.
- In the first solution, proving  $\frac{a}{b} + \frac{b}{c} + \frac{c}{a} \geq a+b+c$  (or the analogous version) and not applying this inequality in both cases such that the application leads to the solution should only be awarded **2 points**.

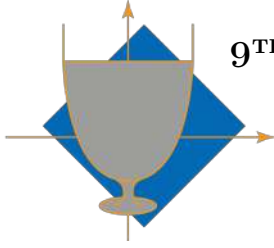

**9<sup>TH</sup> EUROPEAN MATHEMATICAL CUP**  
12<sup>th</sup> December 2020 - 20<sup>th</sup> December 2020  
Senior Category



**Problem 1.** Let  $ABCD$  be a parallelogram such that  $|AB| > |BC|$ . Let  $O$  be a point on the line  $CD$  such that  $|OB| = |OD|$ . Let  $\omega$  be a circle with center  $O$  and radius  $|OC|$ . If  $T$  is the second intersection of  $\omega$  and  $CD$ , prove that  $AT$ ,  $BO$  and  $\omega$  are concurrent.

(Ivan Novak)

**Problem 2.** Let  $n$  and  $k$  be positive integers. An  $n$ -tuple  $(a_1, a_2, \dots, a_n)$  is called a *permutation* if every number from the set  $\{1, 2, \dots, n\}$  occurs in it exactly once. For a permutation  $(p_1, p_2, \dots, p_n)$ , we define its  $k$ -*mutation* to be the  $n$ -tuple

$$(p_1 + p_{1+k}, p_2 + p_{2+k}, \dots, p_n + p_{n+k}),$$

where **indices** are taken modulo  $n$ . Find all pairs  $(n, k)$  such that every two distinct permutations have distinct  $k$ -mutations.

*Remark:* For example, when  $(n, k) = (4, 2)$ , the 2-mutation of  $(1, 2, 4, 3)$  is  $(1 + 4, 2 + 3, 4 + 1, 3 + 2) = (5, 5, 5, 5)$ .

(Borna Šimić)

**Problem 3.** Let  $p$  be a prime number. Troy and Abed are playing a game. Troy writes a positive integer  $X$  on the board, and gives a sequence  $(a_n)_{n \in \mathbb{N}}$  of positive integers to Abed. Abed now makes a sequence of moves. The  $n$ -th move is the following:

Replace  $Y$  currently written on the board with either  $Y + a_n$  or  $Y \cdot a_n$ .

Abed wins if at some point the number on the board is a multiple of  $p$ . Determine whether Abed can win, regardless of Troy's choices, if

- a)  $p = 10^9 + 7$ ;
- b)  $p = 10^9 + 9$ .

*Remark:* Both  $10^9 + 7$  and  $10^9 + 9$  are prime.

(Ivan Novak)

**Problem 4.** Let  $\mathbb{R}^+$  denote the set of all positive real numbers. Find all functions  $f: \mathbb{R}^+ \rightarrow \mathbb{R}^+$  such that

$$xf(x+y) + f(xf(y)+1) = f(xf(x))$$

for all  $x, y \in \mathbb{R}^+$ .

(Amadej Kristjan Kocbek, Jakob Jurij Snoj)

*Time: 240 minutes.*

*Each problem is worth 10 points.*

*The use of calculators or any other instruments except rulers and compasses is not permitted.*

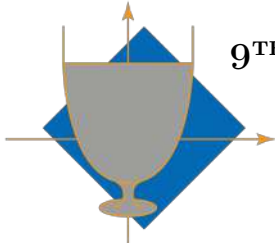

## Problems and Solutions

**Problem 1.** Let  $ABCD$  be a parallelogram in which  $|AB| > |BC|$ . Let  $O$  be a point on the line  $CD$  such that  $|OB| = |OD|$ . Let  $\omega$  be a circle with center  $O$  and radius  $|OC|$ . If  $T$  is the second intersection of  $\omega$  and  $CD$ , prove that  $AT, BO$  and  $\omega$  are concurrent.

**First Solution.** Let  $R$  denote the intersection of  $\omega$  and line  $BO$  such that  $O$  is located between  $B$  and  $R$ . We will prove that  $A, T$  and  $R$  are collinear.

0 points.

Let  $X$  be the intersection of the diagonals of  $ABCD$ .

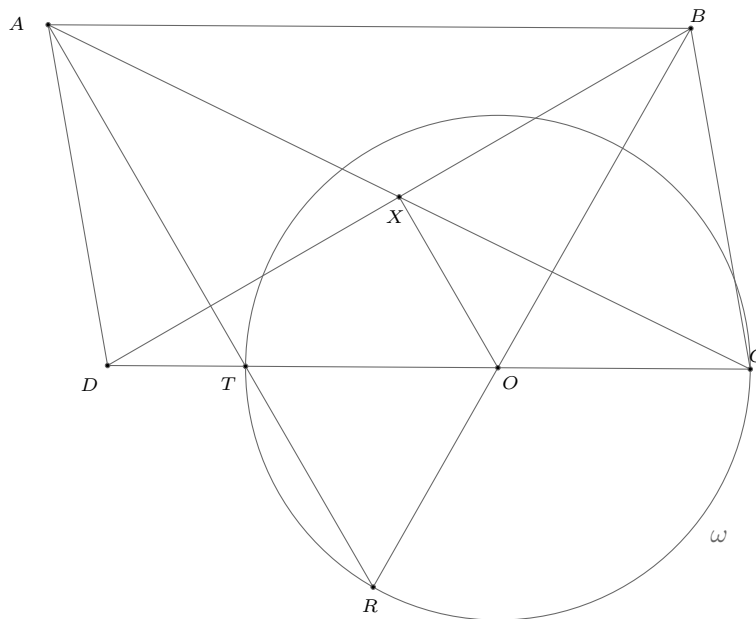

We know that  $X$  is the midpoint of  $\overline{AC}$  and  $O$  is the midpoint of  $\overline{TC}$  so we conclude that  $XO \parallel AT$ .

2 points.

$X$  is also the midpoint of  $\overline{BD}$  so, since triangle  $OBD$  is isosceles,  $OX \perp BD$ .

2 points.

This means that  $AT \perp BD$ .

1 point.

Now because of  $|DO| = |BO|$  we have

$$\angle DOR = 2\angle ODB$$

and because  $|OT| = |OR|$  we have

$$\angle OTR = 90^\circ - \angle ODB$$

2 points.

Finally we have

$$\angle ATD = 90^\circ - \angle BDC = \angle OTR$$

and so  $A, T$  and  $R$  are collinear as desired.

3 points.

**Second Solution.** Define  $R$  as the intersection of the ray  $BO$  with  $\omega$  such that  $O$  is between  $B$  and  $R$ . We will prove that  $A, T$  and  $R$  are collinear.

0 points.

Since  $|BO| = |DO|$  and  $|OR| = |OC|$ , we have:

$$|BR| = |BO| + |OR| = |DO| + |OC| = |CD| = |BA|.$$

Therefore, triangle  $BRA$  is isosceles.

5 points.

Now, due to the triangles  $TOR$  and  $BRA$  being isosceles, we have:

$$|\angle BRA| = \frac{180^\circ - |\angle RBA|}{2}$$

and

$$\frac{180^\circ - |\angle ROT|}{2} = |\angle ORT| = |\angle BRT|$$

.

2 points.

Finally, since  $|\angle RBA| = |\angle TOR|$ , we have

$$|\angle BRA| = |\angle BRT|$$

, so  $R, T$  and  $A$  are collinear, which proves the claim.

3 points.

**Third Solution.** Let  $R'$  be the intersection of line  $AT$  and  $\omega$  different from  $T$ . We will prove that points  $B, O$  and  $R'$  are collinear.

0 points.

Let  $X$  be the intersection of the diagonals of the parallelogram  $ABCD$ .

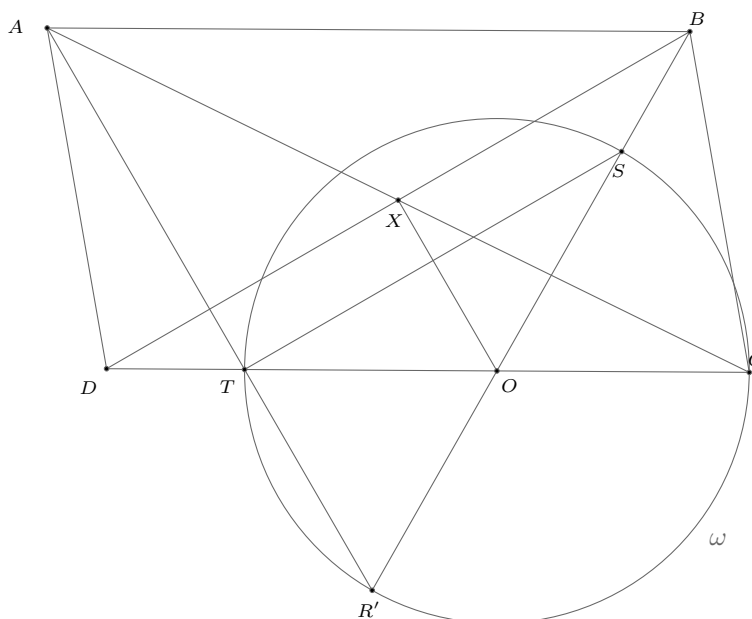

Now as in the first solution we conclude that  $XO \parallel AT$  and  $OX \perp BD$ , which leads to  $AT$  being perpendicular to  $BD$ .

5 points.

Let  $S$  be the intersection of  $\omega$  and ray  $OB$ . Since triangles  $ODB$  and  $OTS$  are isosceles with  $\angle DOB = \angle TOS$ , these triangles are similar, which means that  $TS \parallel BD$ .

2 points.

From this it follows that  $ST \perp AT$ , i.e.  $\angle STR' = 90^\circ$ . This means that  $\overline{SR'}$  is the diameter of  $\omega$ , and as we know that  $B, S$  and  $O$  are collinear, we conclude that  $B, O$  and  $R'$  are collinear.

3 points.

**Fourth Solution.** Let  $R''$  be the intersection of lines  $AT$  and  $BO$ . We will show that  $R''$  lies on the circle  $\omega$ .

0 points.

Let  $X$  be the intersection of the diagonals of the parallelogram  $ABCD$ .

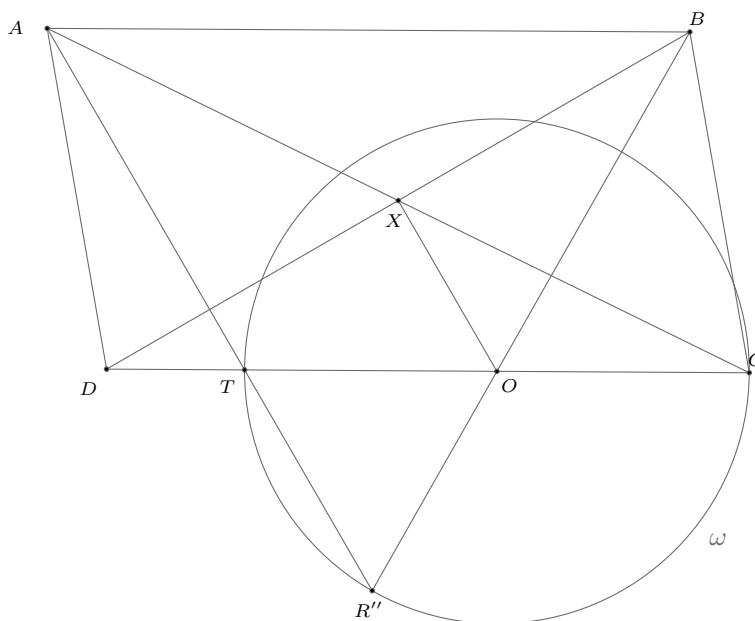

As in the first solution we conclude that  $XO \parallel AT$ ,  $OX \perp BD$  and  $AT \perp BD$ .

5 points.

Denote  $\angle TR''O = \alpha$ . Since  $AT \perp BD$ , we have

$$\angle OBD = 90^\circ - \alpha.$$

Now, due to the triangle  $ODB$  being isosceles, we have

$$\angle ODB = 90^\circ - \alpha.$$

2 points.

Using again the fact that  $AT \perp BD$ , it follows that

$$\angle R''TO = \angle ATD = \alpha.$$

We can now conclude that  $|OT| = |OR''|$ , which proves the claim.

3 points.

**Notes on marking:**

- Points from different solutions are not additive. Student's score should be the maximum of points scored over all solutions.
- If a student has a partial solution with analytic methods, only points for proving facts that can be expressed in geometric ways and lead to a complete solution can be awarded.

**Problem 2.** Let  $n$  and  $k$  be positive integers. An  $n$ -tuple  $(a_1, a_2, \dots, a_n)$  is called a *permutation* if every number from the set  $\{1, 2, \dots, n\}$  occurs in it exactly once. For a permutation  $(p_1, p_2, \dots, p_n)$ , we define its *k-mutation* to be the  $n$ -tuple

$$(p_1 + p_{1+k}, p_2 + p_{2+k}, \dots, p_n + p_{n+k}),$$

where indices are taken modulo  $n$ . Find all pairs  $(n, k)$  such that every two distinct permutations have distinct  $k$ -mutations.

*Remark:* For example, when  $(n, k) = (4, 2)$ , the 2-mutation of  $(1, 2, 4, 3)$  is  $(1 + 4, 2 + 3, 4 + 1, 3 + 2) = (5, 5, 5, 5)$ .

(Borna Šimić)

**First Solution.** Let  $f$  denote the function that, when given a permutation, returns its  $k$ -mutation.

Let  $M(a, b)$  denote the greatest common divisor of  $a$  and  $b$ .

The answer is all  $(n, k)$  such that  $n/M(n, k)$  is odd.

Suppose that  $n/M(n, k)$  is odd.

Consider permutations  $p, q$  such that  $f(p) = f(q)$ . Suppose for the sake of contradiction that there exists some  $t \leq n$  such that  $p_t > q_t$ . We have:

$$p_t + p_{t+k} = q_t + q_{t+k}$$

so we must have  $p_{t+k} < q_{t+k}$ , and  $p_{t+2k} > q_{t+2k}$ . Inductively, we obtain  $p_{t+dk} < q_{t+dk}$  for all odd  $d$  (where the indices are taken modulo  $n$ ).

**2 points.**

However,  $n/M(n, k)$  is odd and we have  $p_{t+nk/M(n, k)} = p_t$  and  $q_{t+nk/M(n, k)} = q_t$ . However, then  $p_t < q_t$ , which is a contradiction. Therefore,  $p = q$ , which proves that all  $(n, k)$  for which  $n/M(n, k)$  is odd are solutions.

**3 points.**

We will now show that when  $n/M(n, k)$  is even, there exist distinct permutations  $p, q$  such that  $f(p) = f(q)$ .

Firstly, fix  $n$ , and for  $(n, k) = (2m, 1)$  for some  $m \in \mathbb{N}$  take:

$$p^1 = (1, 2, 3, \dots, 2m - 1, 2m)$$

$$q^1 = (2, 1, 4, \dots, 2m, 2m - 1)$$

It's easy to see that  $f(p^1) = f(q^1)$ .

**1 point.**

Now, if  $k = 2u - 1$  for some  $u \geq 1$  such that  $M(n, 2u - 1) = 1$ , define permutations  $p^u, q^u$  by taking

$$p_{(m-1)k+1}^u = p_m^1 \text{ and } q_{(i-1)k+1}^u = q_i^1,$$

where indices are taken modulo  $n$ . (For example, for  $p^1$  and  $p^u$ ,  $p_1^u = p_1^1 = 1, p_{k+1}^u = p_2^1 = 2$  and so on).

As  $k$  and  $n$  are relatively prime,  $p^u$  and  $q^u$  are well defined, because the map  $x \mapsto (x - 1)k + 1$  is a bijection on the set of residues modulo  $n$ . Furthermore, it's easy to see that  $f(p^u) = f(q^u)$  holds, because  $f(p^1) = f(q^1)$  holds.

**2 points.**

Finally, a construction for  $(n, 2u - 1)$  can be expanded to a construction for  $(ln, l(2u - 1))$ , by defining  $p(lj) = p^u(j)$  and  $q(lj) = q^u(j)$  for every  $j$ , and setting  $p(x) = q(x)$  for  $x$  which are not divisible by  $l$  (it is not important how  $p$  and  $q$  are defined on the set of numbers not divisible by  $l$ , it's only important that they are equal on this set). Since  $f(p^u) = f(q^u)$ , we conclude that  $f(p) = f(q)$  also holds.

Since any pair of positive integers  $(n, k)$  for which  $n/M(n, k)$  is even can be written in this form, we've proved the claim.

**2 points.**

**Second Solution.** Let the notation be the same as in the first solution. Let  $d$  be an odd positive integer. Consider some permutations  $p, q$  such that  $f(p) = f(q)$ . This gives us the following sequence of equations for  $i = 1, 2, \dots, n$ :

$$p_i + p_{i+k} = q_i + q_{i+k} \tag{1}$$

$$p_{i+k} + p_{i+2k} = q_{i+k} + q_{i+2k} \tag{2}$$

$$\vdots = \vdots$$

$$p_{i+(d-2)k} + p_{i+(d-1)k} = q_{i+(d-2)k} + q_{i+(d-1)k} \tag{d-1}$$

$$p_{i+(d-1)k} + p_{i+dk} = q_{i+(d-1)k} + q_{i+dk} \tag{d}$$

We telescope the equations:  $(d-1) - (d-2) + (d-3) - \dots + \dots - (1)$ . Since  $d$  is odd, we obtain:

$$p_{i+(d-1)k} - p_i = q_{i+(d-1)k} - q_i$$

We subtract that from (d) and obtain:  $p_{i+dk} + p_i = q_{i+dk} + q_i$ .

**2 points.**

Since this equality holds for every odd  $d$ , it also holds for  $n/M(n, k)$ . Since  $p_{i+nk/M(n, k)} = p_i$  and  $q_{i+nk/M(n, k)} = q_i$ , we conclude that  $2p_i = 2q_i$  for all  $i$ . Therefore,  $p = q$ .

**3 points.**

The case where  $n/M(n, k)$  is even is the same as in the first solution.

**5 points.**

**Notes on marking:**

- Note that the set of solutions can also be characterized as the set of all pairs  $(n, k)$  such that  $\nu_2(n) \leq \nu_2(k)$ , where  $\nu_2(x)$  denotes the largest nonnegative integer  $y$  such that  $2^y \mid x$ . Of course, this characterization or any other trivially equivalent characterization of the set of solutions is valid.

**Problem 3.** Let  $p$  be a prime number. Troy and Abed are playing a game. Troy writes a positive integer  $X$  on the board, and gives a sequence  $(a_n)_{n \in \mathbb{N}}$  of positive integers to Abed. Abed now makes a sequence of moves. The  $n$ -th move is the following:

Replace  $Y$  currently written on the board with either  $Y + a_n$  or  $Y \cdot a_n$ .

Abed wins if at some point the number on the board is a multiple of  $p$ . Determine whether Abed can win, regardless of Troy's choices, if

- a)  $p = 10^9 + 7$ ;
- b)  $p = 10^9 + 9$ .

*Remark:* Both  $10^9 + 7$  and  $10^9 + 9$  are prime.

*(Ivan Novak)*

**Solution.** We will prove that Abed cannot win in either case.

**0 points.**

We now explain Troy's strategies. Throughout the solution, we will use fractions modulo  $p$ .

a) Suppose  $p = 10^9 + 7$ . Note that  $p \equiv 2 \pmod{3}$ . Let  $X = 2$ . We will define the sequence  $(a_n)_{n \in \mathbb{N}}$  recursively. Note that neither 2 nor  $2 - 1$  is divisible by  $p$ .

Suppose we've defined  $a_1, \dots, a_{n-1}$ , where  $n \in \mathbb{N}$ , and suppose that whatever Abed's first  $n - 1$  moves are, the number on the board after these  $n - 1$  moves is congruent to  $Y$  modulo  $p$ , and neither  $Y$  nor  $Y - 1$  are divisible by  $p$ . We now prove that there exists a positive integer  $k$  such that  $Y + k \equiv Yk \pmod{p}$ , and neither  $Yk$  nor  $Yk - 1$  are not divisible by  $p$ .

Indeed, let  $k \equiv \frac{Y}{Y-1} \pmod{p}$ . Note that this is well defined since  $Y - 1$  is not divisible by  $p$ . Then  $Y + k \equiv Yk \equiv \frac{Y^2}{Y-1} \pmod{p}$ . Note that  $\frac{Y^2}{Y-1} \not\equiv 0 \pmod{p}$  since  $Y \not\equiv 0 \pmod{p}$ .

**1 point.**

Suppose for the sake of contradiction that  $\frac{Y^2}{Y-1} \equiv 1 \pmod{p}$ . This implies that  $p \mid Y^2 - Y + 1$ . However, this would imply  $p \mid (-Y)^3 - 1$ .

This means that  $\text{ord}_p(-Y) \mid 3$ . Since  $p \equiv 2 \pmod{3}$  and  $\text{ord}_p(-Y) \mid p - 1$ , it follows that  $\text{ord}_p(-Y) \neq 3$ . This forces  $\text{ord}_p(-Y) = 1$ . However, then  $Y \equiv -1 \pmod{p}$ , which implies  $Y^2 - Y + 1 \equiv 3 \not\equiv 0 \pmod{p}$ . Therefore,  $\frac{Y^2}{Y-1} \not\equiv 1 \pmod{p}$ .

**2 points.**

We define  $a_n := k$ . No matter what Abed's first  $n$  moves are, the number on the board after  $n$  moves is congruent to  $\frac{Y^2}{Y-1}$  modulo  $p$ , which is not congruent to 0 or 1 modulo  $p$ . Therefore, Abed cannot win after  $n$  steps. Since this claim is true for any positive integer  $n$ , we conclude that Abed cannot win.

**1 point.**

b) Suppose  $p = 10^9 + 9$ . Note that  $p \equiv 1 \pmod{4}$ , which means that there exists a positive integer  $z$  such that  $z^2 \equiv -1 \pmod{p}$ . Then there also exists a positive integer  $t$  such that  $(2t - 1)^2 \equiv -1 \pmod{p}$ .

Let  $X = t$ . Note that neither  $X$  nor  $X - 1$  are divisible by  $p$ , and note that  $4X^2 - 4X + 2 \equiv 0 \pmod{p}$ .

**1 point.**

Let  $a_1 \equiv \frac{X}{X-1} \pmod{p}$ . Then  $a_1 + X \equiv a_1X \equiv \frac{X^2}{X-1} \pmod{p}$ . Therefore, whatever Abed's first move is, the number on the board after the first move will be congruent to  $\frac{X^2}{X-1}$  modulo  $p$ . Furthermore,  $\frac{X^2}{X-1}$  is not divisible by  $p$  since  $X$  isn't.

Suppose for the sake of contradiction that  $\frac{X^2}{X-1} \equiv 1 \pmod{p}$ . Then  $4X^2 - 4X + 4 \equiv 0 \pmod{p}$ , but, by definition of  $X$ ,  $4X^2 - 4X + 2 \equiv 0 \pmod{p}$ , which implies  $2 \equiv 0 \pmod{p}$ , which is a contradiction. Therefore,  $\frac{X^2}{X-1} \not\equiv 1 \pmod{p}$ .

**1 point.**

Let  $a_2 \equiv \frac{X^2}{X^2 - X + 1} \pmod{p}$ . Note that this is well defined since  $X^2 - X + 1 \not\equiv 0 \pmod{p}$ . Whatever Abed's second move is, the number on the board will be congruent to  $\frac{X^2}{X-1} + \frac{X^2}{X^2 - X + 1} \equiv \frac{X^4}{(X^2 - X + 1)(X - 1)} \pmod{p}$ . Now note that

$$\frac{X^4}{(X^2 - X + 1)(X - 1)} \equiv X \pmod{p} \iff X^3 \equiv (X^2 - X + 1)(X - 1) \pmod{p} \iff 2X^2 - 2X + 1 \equiv 0 \pmod{p},$$

which is true by definition of  $X$ . Therefore, whatever Abed's first two moves are, the number written on the board after the first two moves will be congruent to  $X$  modulo  $p$ .

**4 points.**

Thus, if we define  $a_{2j-1} := a_1$  and  $a_{2j} := a_2$  for  $j \geq 2$ , no matter what moves Abed makes, the number on the board will never be divisible by  $p$ .

**0 points.**

**Notes on marking:**

- Part a) is worth **4 points**, and part b) is worth **6 points**.
- The idea of making it impossible for Abed to affect the numbers on the board modulo  $p$ , although used in both parts, is worth **0 points** on its own.
- In part a), if a student doesn't prove that  $x^2 - x + 1$  doesn't have prime divisors of the form  $3k + 2$ , but instead states that this fact is well known and checks that  $10^9 + 7$  is of the form  $3k + 2$ , they should be awarded all the points intended for this part.
- In part b), the idea of 2-periodicity of the game state is worth **0 points** on its own.
- Due to overlapping arguments, if a student solves b), but does not solve a), then they get **0 points** for the very first point in part a). This point is then merged with the second block of **2 points** in part a).

**Problem 4.** Let  $\mathbb{R}^+$  denote the set of all positive real numbers. Find all functions  $f: \mathbb{R}^+ \rightarrow \mathbb{R}^+$  such that

$$xf(x+y) + f(xf(y)+1) = f(xf(x))$$

for all  $x, y \in \mathbb{R}^+$ .

(Amadej Kristjan Kocbek, Jakob Jurij Snoj)

**First Solution.** Let  $f$  be a function satisfying the equation. We split the solution into a series of claims.

*Claim 1.*  $f(x) < f(f(1))$  for all  $x > 1$ .

*Proof.* Substituting  $x = 1$  gives

$$f(y+1) + f(f(y)+1) = f(f(1)). \quad (3)$$

Since the function only attains positive values, we have  $f(y+1) < f(f(1))$  for all  $y$ , and the conclusion follows.  $\square$

*Claim 2.* The function  $f$  is injective.

*Proof.* Assume the contrary and choose  $a < b$  such that  $f(a) = f(b)$ . Substituting  $y = a$  and, afterwards,  $y = b$  into the original equations and comparing the equations gives

$$f(x+a) = f(x+b) \quad \text{for all } x \in \mathbb{R}^+.$$

Hence,  $f$  is periodic for all  $x \geq P$  for some constant  $P \in \mathbb{R}^+$  with period  $p = b - a$ . Fix some  $x_1, y_1 \in \mathbb{R}^+$  with  $x_1 > P$  and pick a positive integer  $n$  such that  $(x_1 + np)f(x_1 + y_1) \geq f(f(1))$  and  $(x_1 + np)f(x_1) > 1$ . Substituting  $x = x_1 + np, y = y_1$  gives

$$\begin{aligned} (x_1 + np)f((x_1 + np) + y_1) + f((x_1 + np)f(y_1) + 1) &= f((x_1 + np)f(x_1 + np)) \\ (x_1 + np)f(x_1 + y_1) + f((x_1 + np)f(y_1) + 1) &= f((x_1 + np)f(x_1)) \end{aligned}$$

after using periodicity to simplify the equation. Due to our choice of  $n$  and the function only attaining positive values, we have

$$f((x_1 + np)f(x_1)) > (x_1 + np)f(x_1 + y_1) > f(f(1)).$$

However, since we have  $(x_1 + np)f(x_1) > 1$ , Claim 1 implies  $f((x_1 + np)f(x_1)) < f(f(1))$ , leading to a contradiction. Therefore, such  $a$  and  $b$  do not exist and  $f$  is injective.  $\square$

**2 points.**

*Claim 3.*  $f(f(x)) = x$  for all  $x \in \mathbb{R}^+$ .

*Proof.* We substitute  $y = f(y)$  into (1). Comparing the resulting equation with (1) gives:

$$\begin{aligned} f(f(y)+1) + f(f(f(y))+1) &= f(y+1) + f(f(y)+1) \\ f(f(f(y))+1) &= f(y+1) \end{aligned}$$

Using injectivity, we get  $f(f(y)) = y$  for all  $y \in \mathbb{R}^+$ .  $\square$

**1 point.**

*Claim 4.* For all  $x \in \mathbb{R}^+$ ,  $xf(x) \leq 1$ . In particular,  $f(a) \leq \frac{1}{a}$  for all  $a \geq x$ .

*Proof.* Assume the contrary - there exists some  $c \in \mathbb{R}^+$  such that  $cf(c) > 1$ . Substituting  $y = f(y)$  and using Claim 3, we transform the original equation:

$$xf(x+f(y)) + f(xy+1) = f(xf(x)).$$

Substituting  $x = c, y = \frac{cf(c)-1}{c}$  into the above equation gives  $cf(c + f((cf(c)-1)/c)) = 0$  after cancellation of the terms, a clear contradiction. The second part of the claim follows immediately.  $\square$

**1 point.**

*Claim 5.* For all  $x \in \mathbb{R}^+$ , we have  $f(xf(x)) \leq 1$ .

*Proof.* We notice

$$f(xf(x)) = xf(x+y) + f(xf(y)+1) < xf(x+y) + 1 \leq \frac{x}{x+y} + 1,$$

where the inequalities hold due to Claim 1 and Claim 4, respectively, as well as the identity  $f(f(1)) = 1$ . Assume there exists a  $c$  such that  $f(cf(c)) > 1$ : therefore, it should hold that

$$f(cf(c)) < \frac{c}{c+y} + 1.$$

However, the left hand side of the above inequality is independent of  $y$ . Thus, for  $y$  sufficiently large, the opposite direction of the inequality will hold since  $c/(c+y)$  can get arbitrarily small, which leads to a contradiction.  $\square$

**1 point.**

*Claim 6.* For all  $x \in \mathbb{R}^+$ ,  $f(xf(x)) \geq 1$ .

*Proof.* Assume the contrary. Therefore, there exists some  $a$  such that  $f(af(a)) < 1$ , let  $f(af(a)) = 1 - e$ . By Claim 4, there exists a  $Y \in \mathbb{R}^+$  such that  $f(y+1) < e$  for all  $y > Y$ . Let  $d > Y$ . Observing (1) after substituting  $y = d$ , we notice

$$f(f(d) + 1) = 1 - f(d + 1) > 1 - e.$$

Substituting  $x = a, y = f\left(\frac{f(d)}{a}\right)$  into the original equation gives

$$1 - e = f(af(a)) = af\left(a + f\left(\frac{f(d)}{a}\right)\right) + f(f(d) + 1) > 1 - e,$$

a contradiction. □

**4 points.**

Finally, observe Claims 5 and 6 together yield  $f(xf(x)) = 1$  for all  $x \in \mathbb{R}^+$ . By injectivity,  $xf(x)$  is constant, hence  $f(x) = \frac{c}{x}$  for some constant  $c \in \mathbb{R}^+$ . By checking, we see  $c = 1$  yields the only valid solution,  $f(x) = \frac{1}{x}$ .

**1 point.**

**Second Solution.** We present an alternative way of proving  $f(xf(x))$  is constant after obtaining the first four claims of the first solution.

Assume there exist  $a$  and  $b$  such that  $f(af(a)) - f(bf(b)) \neq 0$ . Without loss of generality, we can assume  $f(af(a)) - f(bf(b)) > 0$ . We now substitute  $(x, y)$  with  $(a, f\left(\frac{x}{a}\right))$  and  $(b, f\left(\frac{x}{b}\right))$  and subtract the resulting equations to obtain

$$\begin{aligned} f(af(a)) - f(bf(b)) &= af\left(a + f\left(\frac{x}{a}\right)\right) - bf\left(b + f\left(\frac{x}{b}\right)\right) + f\left(af\left(f\left(\frac{x}{a}\right)\right) + 1\right) - f\left(bf\left(f\left(\frac{x}{b}\right)\right) + 1\right) \\ &= af\left(a + f\left(\frac{x}{a}\right)\right) - bf\left(b + f\left(\frac{x}{b}\right)\right) + f\left(a \cdot \frac{x}{a} + 1\right) - f\left(b \cdot \frac{x}{b} + 1\right) \\ &= af\left(a + f\left(\frac{x}{a}\right)\right) - bf\left(b + f\left(\frac{x}{b}\right)\right). \end{aligned}$$

**1 point.**

This shows that, as  $x$  varies, the expression  $af\left(a + f\left(\frac{x}{a}\right)\right) - bf\left(b + f\left(\frac{x}{b}\right)\right)$  is constant. As  $f$  is an involution and thus surjective, we can choose a number  $x_1 \in \mathbb{R}^+$  such that  $a + f\left(\frac{x_1}{a}\right) > \frac{a}{f(af(a)) - f(bf(b))}$ . Substituting  $x$  with  $x_1$  in the above equation and using Claim 4, we obtain

$$\begin{aligned} f(af(a)) - f(bf(b)) &= af\left(a + f\left(\frac{x_1}{a}\right)\right) - bf\left(b + f\left(\frac{x_1}{b}\right)\right) \\ &< af\left(a + f\left(\frac{x_1}{a}\right)\right) \\ &\leq \frac{a}{a + f\left(\frac{x_1}{a}\right)} \\ &< f(af(a)) - f(bf(b)), \end{aligned}$$

which leads to a contradiction. Therefore,  $f(xf(x))$  is constant.

**4 points.**

As in the first solution, this now implies  $xf(x)$  is constant, therefore,  $f$  is of the form  $f(x) = \frac{c}{x}$  for some constant  $c$ . We can easily check  $f(x) = \frac{1}{x}$  is the only valid solution.

**1 point.**

**Notes on marking:**

- If a student doesn't check that  $f(x) = \frac{1}{x}$  is indeed a solution or at least mention that it can be easily checked, they should lose **1 point**.
- Points from two marking schemes are not additive.



# Statistics of the 9th European Mathematical Cup

12th Dec 2020 - 20th Dec 2020



## Junior Category

#	J1	J2	J3	J4	Graph J1	Graph J2	Graph J3	Graph J4
0	72	96	95	204				
1	10	24	73	10				
2	46	10	46	9				
3	3	8	3	4				
4	4	5	11	6				
5	11	7	2	2				
6	4	3	8	1				
7	3	5	1	1				
8	0	5	6	2				
9	3	20	5	1				
10	110	83	16	26				
$\Sigma$	266	266	266	266				
$\mu$	5.09	4.61	2.02	1.40				
$\sigma$	4.43	4.49	2.85	3.13				

## Senior Category

#	S1	S2	S3	S4	Graph S1	Graph S2	Graph S3	Graph S4
0	25	119	182	221				
1	3	8	11	4				
2	2	2	5	6				
3	4	11	0	4				
4	0	2	18	3				
5	1	18	3	0				
6	1	5	7	0				
7	5	2	0	0				
8	4	2	0	0				
9	7	7	1	0				
10	186	62	11	0				
$\Sigma$	238	238	238	238				
$\mu$	8.49	3.72	1.13	0.17				
$\sigma$	3.33	4.34	2.53	0.67				

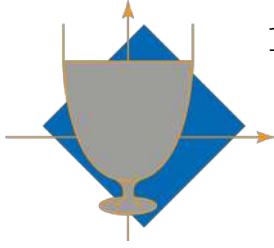

# 10<sup>TH</sup> EUROPEAN MATHEMATICAL CUP

11<sup>th</sup> December 2021 - 19<sup>th</sup> December 2021

Junior Category



**Problem 1.** We say that a quadruple of nonnegative real numbers  $(a, b, c, d)$  is *balanced* if

$$a + b + c + d = a^2 + b^2 + c^2 + d^2.$$

Find all positive real numbers  $x$  such that

$$(x - a)(x - b)(x - c)(x - d) \geq 0$$

for every balanced quadruple  $(a, b, c, d)$ .

*(Ivan Novak)*

**Problem 2.** Let  $ABC$  be an acute-angled triangle such that  $|AB| < |AC|$ . Let  $X$  and  $Y$  be points on the minor arc  $\widehat{BC}$  of the circumcircle of  $ABC$  such that  $|BX| = |XY| = |YC|$ . Suppose that there exists a point  $N$  on the segment  $\overline{AY}$  such that  $|AB| = |AN| = |NC|$ . Prove that the line  $NC$  passes through the midpoint of the segment  $\overline{AX}$ .

*(Ivan Novak)*

**Problem 3.** Let  $\ell$  be a positive integer. We say that a positive integer  $k$  is *nice* if  $k! + \ell$  is a square of an integer. Prove that for every positive integer  $n \geq \ell$ , the set  $\{1, 2, \dots, n^2\}$  contains at most  $n^2 - n + \ell$  nice integers.

*(Théo Lenoir)*

**Problem 4.** Let  $n$  be a positive integer. Morgane has coloured the integers  $1, 2, \dots, n$ . Each of them is coloured in exactly one colour. It turned out that for all positive integers  $a$  and  $b$  such that  $a < b$  and  $a + b \leq n$ , at least two of the integers among  $a$ ,  $b$  and  $a + b$  are of the same colour. Prove that there exists a colour that has been used for at least  $2n/5$  integers.

*(Vincent Jugé)*

*Time: 240 minutes.*

*Each problem is worth 10 points.*

*The use of calculators or any other instruments except rulers and compasses is not permitted.*

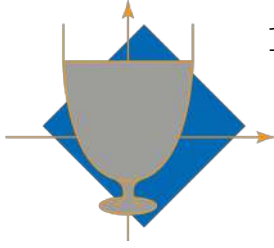

# 10<sup>TH</sup> EUROPEAN MATHEMATICAL CUP

11<sup>th</sup> December 2021 - 19<sup>th</sup> December 2021

Junior Category



## Problems and Solutions

**Problem 1.** We say that a quadruple of nonnegative real numbers  $(a, b, c, d)$  is *balanced* if

$$a + b + c + d = a^2 + b^2 + c^2 + d^2.$$

Find all positive real numbers  $x$  such that

$$(x - a)(x - b)(x - c)(x - d) \geq 0$$

for every balanced quadruple  $(a, b, c, d)$ .

(Ivan Novak)

**First Solution.** We'll call any  $x \in (0, \infty)$  satisfying the problem's condition *great*. Let  $(a, b, c, d)$  be a balanced quadruple. Without loss of generality let  $a \geq b \geq c \geq d$ . We can rewrite the equation  $a^2 + b^2 + c^2 + d^2 = a + b + c + d$  as

$$\left(a - \frac{1}{2}\right)^2 + \left(b - \frac{1}{2}\right)^2 + \left(c - \frac{1}{2}\right)^2 + \left(d - \frac{1}{2}\right)^2 = 1,$$

which implies  $\left(a - \frac{1}{2}\right)^2 \leq 1$ , meaning that  $a \leq \frac{3}{2}$ .

**6 points.**

If we take  $x \geq \frac{3}{2}$ , the values of  $x - a$ ,  $x - b$ ,  $x - c$  and  $x - d$  are all nonnegative. Thus, any  $x \geq \frac{3}{2}$  is great.

**1 point.**

If we take  $(a, b, c, d) = (\frac{3}{2}, \frac{1}{2}, \frac{1}{2}, \frac{1}{2})$ , then for any  $x \in (\frac{1}{2}, \frac{3}{2})$  we have  $(x - a)(x - b)(x - c)(x - d) < 0$ . Thus, no  $x \in (\frac{1}{2}, \frac{3}{2})$  is great.

**2 points.**

If we take  $(a, b, c, d) = (1, 0, 0, 0)$ , then for any  $x \in (0, 1)$  we have  $(x - a)(x - b)(x - c)(x - d) < 0$ . Thus, no  $x \in (0, 1)$  is great.

**1 point.**

We conclude that a number  $x$  is great if and only if  $x \geq \frac{3}{2}$ .

**Second Solution.** Here we present another way to conclude that all  $x \geq \frac{3}{2}$  satisfy the condition. As in the first solution, we call any  $x \in (0, \infty)$  which satisfies the problem's condition *great*, and without loss of generality let  $(a, b, c, d)$  be a balanced quadruple satisfying  $a \geq b \geq c \geq d$ . We notice that for all  $y \in \mathbb{R}$  we have

$$\left(y - \frac{1}{2}\right)^2 \geq 0 \implies y^2 \geq y - \frac{1}{4}.$$

Applying this inequality to  $b, c$  and  $d$  separately and summing the inequalities we get the following:

$$\begin{cases} b^2 \geq b - \frac{1}{4} \\ c^2 \geq c - \frac{1}{4} \\ d^2 \geq d - \frac{1}{4} \end{cases} \implies b^2 + c^2 + d^2 \geq b + c + d - \frac{3}{4}.$$

**3 points.**

Using the equality  $b^2 + c^2 + d^2 = a + b + c + d - a^2$  transforms the inequality above into

$$a \geq a^2 - \frac{3}{4} \implies 1 \geq \left(a - \frac{1}{2}\right)^2,$$

which implies  $a \leq \frac{3}{2}$ ,

**3 points.**

meaning that all  $x \geq \frac{3}{2}$  are great.

**1 point.**

The rest of the solution is the same as the previous solution.

**Problem 2.** Let  $ABC$  be an acute-angled triangle such that  $|AB| < |AC|$ . Let  $X$  and  $Y$  be points on the minor arc  $BC$  of the circumcircle of  $ABC$  such that  $|BX| = |XY| = |YC|$ . Suppose that there exists a point  $N$  on the segment  $\overline{AY}$  such that  $|AB| = |AN| = |NC|$ . Prove that the line  $NC$  passes through the midpoint of the segment  $\overline{AX}$ .

(Ivan Novak)

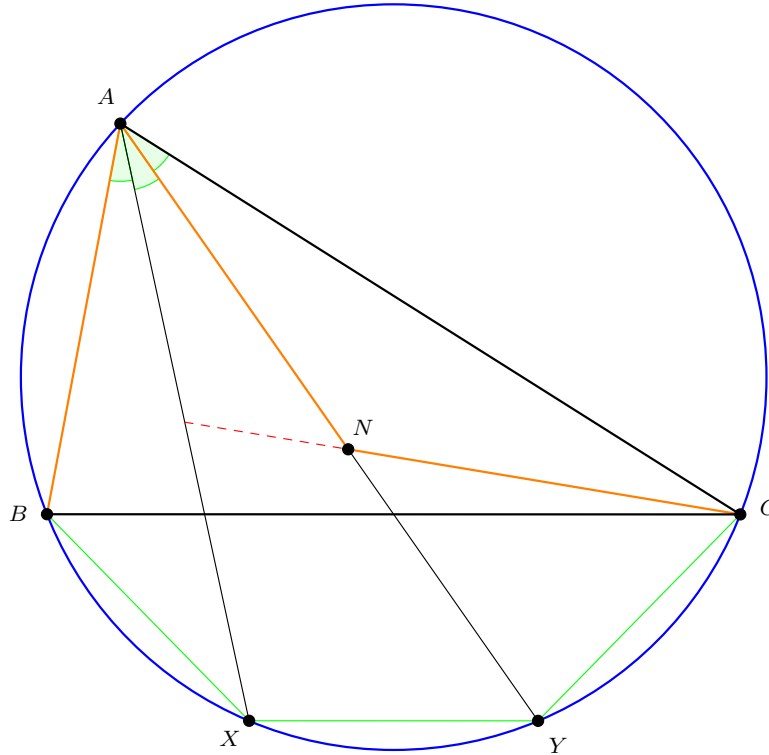

**First Solution.** Let the line  $CN$  intersect the circumcircle of  $ABC$  at  $T \neq C$ .

Since  $|BX| = |XY| = |YC|$ , we have  $\sphericalangle BAX = \sphericalangle XAY = \sphericalangle YAC$ . Denote that angle by  $\varphi$ . Furthermore, since  $|AN| = |NC|$ , we have  $\sphericalangle NAC = \sphericalangle NCA = \varphi$ , which means that  $|AT| = |CY|$ .

1 point.

Furthermore, from  $|AB| = |AN|$  and  $\sphericalangle BAX = \sphericalangle XAY$  it follows that  $AX$  is the perpendicular bisector of  $\overline{BN}$ , so  $|XN| = |BX|$ . Since  $|BX| = |CY| = |AT|$ , we have  $|XN| = |AT|$ .

3 points.

Now  $ATBX$  is an isosceles trapezoid because  $|AT| = |BX|$  and because it's cyclic, which means that  $|AB| = |TX|$ , which, combined with the fact that  $|AB| = |AN|$ , yields  $|TX| = |AN|$ .

3 points.

Therefore, from  $|TX| = |AN|$  and  $|XN| = |AT|$  we have that triangles  $ATX$  and  $ANX$  are congruent, as well as triangles  $ATN$  and  $XTN$ . Therefore,  $\sphericalangle ATX = \sphericalangle ANX$  and  $\sphericalangle TAN = \sphericalangle TXN$ , which means that  $ATXN$  is a parallelogram. Now, as  $NT$  and  $AX$  are diagonals of a parallelogram,  $NT$  passes through the midpoint of  $\overline{AX}$ , which proves the claim.

3 points.

**Second Solution.** Let  $l$  be the line parallel to  $AB$  through  $C$ , and let  $P$  be the intersection of  $l$  and  $AY$ . Let  $\alpha$  denote the angle  $\sphericalangle BAC$ .

From  $|AN| = |NC|$  it follows that  $\sphericalangle ABX = \sphericalangle XAN = \sphericalangle NAC = \sphericalangle NCA = \frac{\alpha}{3}$ . Then it's easy to see that  $\sphericalangle CNP = \sphericalangle NAC + \sphericalangle NCA = \frac{2\alpha}{3}$ .

1 point.

Similarly,  $\sphericalangle NPC = \sphericalangle PAB = \frac{2\alpha}{3}$  by definition of  $P$ .

2 points.

Thus, the triangle  $CNP$  is isosceles. Therefore, we conclude that  $|CN| = |PC|$ .

**1 point.**

However,  $|CN| = |AN| = |AB|$ , which implies  $|AB| = |PC|$ . Since  $AB$  and  $PC$  are parallel, this means that  $ABPC$  is a parallelogram.

**2 points.**

This implies that  $AY$  is the  $A$ -median of triangle  $ABC$ . Since  $AX$  is isogonal to  $AY$  with respect to  $\sphericalangle BAC$ , we conclude that  $AX$  is the  $A$ -symmedian in the triangle  $ABC$ .

**1 point.**

From a well-known lemma, it now follows that  $CB$  is the  $C$ -symmedian in the triangle  $AXC$ . Note that

$$\angle BCX = \angle BAX = \angle NAC = \angle NCA.$$

We now see that  $CN$  and  $CB$  are isogonal with respect to  $\angle ACX$ . Hence,  $CN$  is the  $C$ -median of triangle  $ACX$  and we are done.

**3 points.**

**Third Solution.** Denote the angles of  $ABC$  by  $\alpha, \beta$  and  $\gamma$  in a standard way, so that  $\alpha = \angle BAC$ ,  $\beta = \angle CBA$  and  $\gamma = \angle ACB$ .

Note that  $\angle BCX = \frac{\alpha}{3}$  and  $\angle WCA = \angle NCA = \angle NAC = \frac{\alpha}{3}$  since  $NCA$  is isosceles. Thus,  $\angle WCX = \angle BCA = \gamma$ . Also, note that  $\angle WAC = \frac{2\alpha}{3}$ .

From sine law in triangle  $ANC$ , we have  $\frac{|AN|}{\sin \frac{\alpha}{3}} = \frac{|AC|}{\sin \frac{2\alpha}{3}}$ . Using the fact that  $\frac{|AB|}{|AC|} = \frac{\sin \gamma}{\sin \beta}$  and  $|AB| = |AN|$ , we get the equality

$$\sin \gamma \sin \frac{2\alpha}{3} = \sin \beta \sin \frac{\alpha}{3}. \quad (1)$$

**3 points.**

Let  $W$  denote the intersection of  $AX$  and  $NC$ . From sine law in triangle  $AWC$ , we have

$$\frac{|AW|}{|WC|} = \frac{\sin \frac{\alpha}{3}}{\sin \frac{2\alpha}{3}}.$$

**1 point.**

From sine law in  $WXC$ , we have

$$\frac{|WX|}{|WC|} = \frac{\sin \gamma}{\sin \beta}.$$

**1 point.**

From these two equalities we get

$$\frac{|AW|}{|WX|} = \frac{\sin \beta \sin \frac{\alpha}{3}}{\sin \gamma \sin \frac{2\alpha}{3}},$$

which equals 1 by (1). Thus,  $|AW| = |WX|$ .

**5 points.**

**Notes on marking:**

- In the second solution, proving that it suffices to prove that  $AY$  is the  $A$ -median of  $ABC$  (last **4 points**) is worth at most **2 points** if a student doesn't prove the parts before that.

**Problem 3.** Let  $\ell$  be a positive integer. We say that a positive integer  $k$  is *nice* if  $k! + \ell$  is a square of an integer. Prove that for every positive integer  $n \geq \ell$ , the set  $\{1, 2, \dots, n^2\}$  contains at most  $n^2 - n + \ell$  nice integers.

(Theo Lenoir)

**Solution.** We claim that for every  $k \geq \ell + 1$ , at most one number among  $k^2 - 1$  and  $k^2$  is nice.

1 point.

Suppose for the sake of contradiction that both  $k^2 - 1$  and  $k^2$  are nice for some  $k \geq \ell + 1$ .

Let  $u = \sqrt{(k^2 - 1)! + \ell}$  and  $v = \sqrt{(k^2)! + \ell}$ . Then

$$v^2 - \ell = (k^2)! = k^2(u^2 - \ell),$$

which can be rearranged into

$$(ku)^2 - v^2 = (k^2 - 1)\ell. \quad (1)$$

2 points.

Note that this implies  $ku > v$  and, furthermore,

$$(ku)^2 - v^2 = (ku - v)(ku + v) \geq ku + v > ku > k\sqrt{(k^2 - 1)!} = \sqrt{(k^2)!}$$

Furthermore, we have the following bounds:

$$(k^2)! \geq k^2(k^2 - 1)(k^2 - 2) > k^2(k^2 - 1)(k - 1)^2 > (k^2 - 1)^2(k - 1)^2 \geq (k^2 - 1)^2\ell^2,$$

where we used the fact that  $k^2 - 2 > (k - 1)^2 = k^2 - 2k + 1$  for  $k \geq 2$  and the assumption  $\ell \leq k - 1$ . But this implies that the left hand side in (1) is greater than the right hand side, which is a contradiction.

7 points.

Thus, there is at least one integer which is not good among  $\{k^2 - 1, k^2\}$  for every  $k \in \{\ell + 1, \dots, n\}$ , which means there are at least  $n - \ell$  integers which aren't good. Thus, the claim is proven.

**Partial solution.** This is a sketch of a partial solution using analytic number theory. This is not a solution to the original problem, but it provides a better asymptotic bound on the number of nice integers. This solution is worth **5 points** in total.

We first solve the case where  $\ell$  is not a perfect square. Let  $p$  be a prime such that  $\nu_p(\ell)$  is odd. Then for every  $k \geq 2p$ , we have  $\nu_p(k! + \ell) = \nu_p(\ell)$ , which is odd. Hence, every  $k \geq 2p$  is not nice, so there are at most  $2\ell$  nice numbers and  $2\ell \leq n^2 - n + \ell$  for  $\ell \geq 2$ .

1 point.

Now consider the case when  $\ell$  is a square. Then  $\ell + 1$  is not a perfect square. Note that  $(p - 2)! \equiv 1 \pmod{p}$  for every prime number  $p$ , and thus  $(p - 2)! + \ell \equiv \ell + 1 \pmod{p}$ . If we pick  $p$  to be a prime such that  $\ell + 1$  is not a quadratic residue modulo  $p$ , we conclude that  $(p - 2)! + \ell$  is not a square.

1 point.

Note that, by quadratic reciprocity,  $\ell + 1$  being a quadratic residue modulo  $p$  for  $p > \ell + 1$  depends only on the remainder of  $p$  modulo  $8(\ell + 1)$ , and since  $\ell + 1$  is not a square, there must exist a class of residues modulo  $8(\ell + 1)$  such that  $\ell + 1$  is not a quadratic residue modulo primes from that class.

1 point.

By Dirichlet's theorem on arithmetic progressions, the number of primes less than some  $N$  which are from a given class of residues modulo  $8(\ell + 1)$  is asymptotically

$$\frac{1}{\varphi(8(\ell + 1))} \pi(N),$$

where  $\pi(N)$  is the number of primes less than  $N$  and  $\varphi$  is the Euler's Totient function. By Prime number theorem,  $\pi(N)$  is asymptotically  $N/\log(N)$ . Hence, for large  $n$ , the number of integers less than  $n^2$  which are not nice is at least

$$c \cdot \frac{n^2}{\log(n^2)},$$

where  $c > 0$  is some constant. For  $n$  large enough, this is obviously bigger than  $n - \ell$ .

2 points.

**Notes on marking:**

- In the second solution, if a contestant isn't rigorous enough with the bounds in the end, they shouldn't get more than **1 point** for the last part.
- Points from the second solution are not additive with the points from the first solution.

**Problem 4.** Let  $n$  be a positive integer. Morgane has coloured the integers  $1, 2, \dots, n$ . Each of them is coloured in exactly one colour. It turned out that for all positive integers  $a$  and  $b$  such that  $a < b$  and  $a + b \leq n$ , at least two of the integers among  $a$ ,  $b$  and  $a + b$  are of the same colour. Prove that there exists a colour that has been used for at least  $2n/5$  integers.

(Vincent Juge)

**First Solution.** Throughout the solution, instead of colourings, we will consider partitions, and 'being coloured in the same colour' will be interpreted as 'being in the same element of a partition', and the colours will be interpreted as the blocks of partitions.

Let  $A$  denote the first colour that appears, i.e. the block that contains 1. Also, let  $B$  denote the block which contains the first integer not in  $A$ .

We shall prove that either  $A$  or  $B$  has at least  $2n/5$  elements.

Let  $C$  be the union of all blocks other than  $A$  and  $B$ , and let  $b$  be the smallest element of  $B$ .

**Lemma 1.** For any  $x$ , if  $x \in C$  then  $x - 1 \in A$  and either  $x + 1 \in A$  or  $x = n$ .

**Proof.** We'll actually prove a stronger claim: If  $x \in C$ , then  $x - 1, x - 2, \dots, x - (b - 1) \in A$  and  $x + 1, x + 2, \dots, x + (b - 1) \in A$  if they're not greater than  $n$ .

1 point.

For the sake of contradiction, consider the least  $x$  for which this claim doesn't hold. But then  $x - j \notin C$  for any  $j < b$  since otherwise  $x - j$  would be the least counterexample since  $(x - j) + j \in C$ . Since  $j \in A$  for  $j < b$ , we conclude that  $x - j \in A$  for all  $j < b$ .

Now, for any  $i < b$ , we have  $b \in B$  and  $x + i - b \in A$ , which implies  $x + i \in A \cup B$ . We also have  $x \in C$  and  $i \in A$ , which implies  $x + i \in C \cup A$ . Hence,  $x + i \in A$ . But then  $x + 1, \dots, x + b - 1$  are all in  $A$ , a contradiction.

We conclude that the stronger claim holds for every  $x$ . Thus, the lemma is proven.

1 point.

□

**Lemma 2.** There do not exist  $x$  and  $y$  such that  $x \in B$ ,  $x + 1 \in B$ ,  $y \in C$ ,  $y + 2 \in C$ .

**Proof.** Assume that there exist such  $x$  and  $y$  and assume that such  $x$  is minimal. Note that then  $x - 1 \notin B$  and  $1 \in A$ , so  $x - 1 \in A$ .

We now distinguish two cases, depending on whether  $x > y$  or not.

- If  $x > y$ , consider the integer  $r = x - y = (x + 1) - (y + 1)$ . Since  $x \in B$  and  $y \in C$ ,  $r \in B \cup C$ . Since  $x + 1 \in B$  and  $y + 1 \in A$ ,  $r \in B \cup A$ . Hence,  $r \in B$ . Similarly, consider  $r + 1 = (x + 1) - y = x - (y - 1)$ . Since  $x + 1 \in B$  and  $y \in C$ ,  $r + 1 \in B \cup C$ . Since  $x \in B$  and  $y - 1 \in A$ ,  $r + 1 \in A \cup B$ . Hence,  $r + 1 \in B$ .
- If  $x < y$ , consider the integer  $r = (y + 1) - x = (y + 2) - (x + 1)$ . Since  $y + 1 \in A$  and  $x \in B$ ,  $r \in A \cup B$ . Since  $y + 2 \in C$  and  $x + 1 \in B$ ,  $r \in C \cup B$ . We conclude that  $r \in B$ .

However,  $y \in C$  and  $y + 1 - x \in B$  implies that the integer  $x - 1 = y - (y + 1 - x)$  is either in  $B$  or  $C$ , but we've already proven that  $x - 1 \in A$ . Thus, we've reached a contradiction.

3 points.

However, since  $r = x - y < x$ , this contradicts the minimality of  $x$  and we've reached a contradiction again.

3 points.

□

Now we've proved that there either doesn't exist  $x \in B$  such that  $x + 1 \in B$ , or that there doesn't exist  $y \in C$  such that  $y + 2 \in C$ .

In the first case, for every  $x \in B$ , we have  $x - 1 \notin B$  and  $1 \in A$ . Hence,  $x - 1 \in A$ . But then  $|A| \geq n/2$ , since  $x \mapsto x - 1$  is an injective function from  $B \cup C$  to  $A$ .

1 point.

In the second case, for every  $y \in C$ , both  $y + 1$  and  $y - 1$  are either in  $A$  or greater than  $n$ , while  $y + 2$  and  $y - 2$  are not in  $A$ . Thus,  $y \mapsto y - 1$  and  $y \mapsto y + 1$  are injective functions from  $C$  to  $A$  and  $A \cup \{n + 1\}$  respectively, and their images are disjoint. Additionally noting that  $1 \in A$  and  $1 \neq y - 1, y + 1$  for any  $y \in C$ , we conclude that  $|C| \leq \frac{|A|}{2}$ . But then  $n = |A| + |B| + |C| \leq \frac{3|A| + 2|B|}{2}$ , so either  $|A|$  or  $|B|$  must be greater than or equal to  $\frac{2n}{5}$ .

1 point.

**Second Solution.** We give an alternative proof of **Lemma 1**.

Assume for the sake of contradiction that there are two consecutive integers  $x$  and  $x + 1$  such that both are in  $C$ . Let  $x$  be the smallest integer with that property. Consider the integer  $(x + 1) - b = x - (b - 1)$ . Since  $x + 1 \in C$  and  $b \in B$ , we have either  $x + 1 - b \in C$  or  $x + 1 - b \in B$ . Since  $x \in C$  and  $b - 1 \in A$ , we have either  $x + 1 - b \in C$  or  $x + 1 - b \in A$ . We conclude that  $x + 1 - b \in C$ .

Furthermore, considering  $x - b = (x + 1 - b) - 1$ , we have  $x \in C$ ,  $b \in B$ ,  $x + 1 - b \in C$  and  $1 \in A$ . We conclude that  $x - b \in C$ , but then  $x - b$  and  $x + 1 - b$  are both in  $C$ , contradicting the minimality of  $x$ . We conclude that there are no consecutive integers in  $C$ .

**1 point.**

Now, for all  $x \in C$ , the integers  $x - 1$  and  $x + 1$  must either be equal to  $n + 1$  or belong to  $A$ , since  $1 \in A$ ,  $x - 1 \notin C$  and  $x + 1 \notin C$ .

**1 point.**

□

We also give a slightly different proof of **Lemma 2**.

**Proof.** We first prove that if  $x$  and  $x + 1$  are both in  $B$  and are greater than  $y \in C$ , then  $x - y + 1$  and  $x - y$  are both in  $B$ . Note that  $y + 1 \in A$  and  $y - 1 \in A$  by **Lemma 1**.

Note that  $x - y = (x + 1) - (y + 1)$ , so  $x - y \in B \cup C$  and  $x - y \in B \cup A$ , which implies  $x - y \in B$ . Similarly, considering  $(x + 1) - y = x - (y - 1)$ , we can conclude that  $x - y + 1 \in B$ .

**2 points.**

To now prove **Lemma 2**, it suffices to consider the case  $x < y$ , where  $x$  and  $y$  are from the statement of the lemma.

**1 point.**

We deal with that case in the same way as in the first solution.

**3 points.**

□

The remainder of the solution is the same.

**2 points.**

**Notes on marking:**

- Lemma 2 is worth **6 points**. If a contestant states Lemma 2 and they don't prove any of its two subcases, they should get **1 point** for Lemma 2.
- In the second solution, proving the first part of Lemma 2 is worth less than the case  $x > y$  in the first solution, because one can prove this part without stating Lemma 2. Proving this part in the context of Lemma 2 is worth **3 points**, and without the context of Lemma 2 it's worth **2 points**.

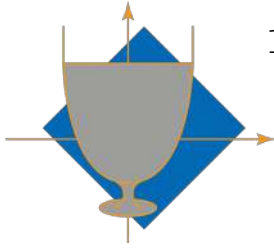

# 10<sup>TH</sup> EUROPEAN MATHEMATICAL CUP

11<sup>th</sup> December 2021 - 19<sup>th</sup> December 2021

Senior Category



**Problem 1.** Alice drew a regular 2021-gon in the plane. Bob then labelled each vertex of the 2021-gon with a real number, in such a way that the labels of consecutive vertices differ by at most 1. Then, for every pair of non-consecutive vertices whose labels differ by at most 1, Alice drew a diagonal connecting them. Let  $d$  be the number of diagonals Alice drew. Find the least possible value that  $d$  can obtain.

*(Ivan Novak)*

**Problem 2.** Let  $ABC$  be a triangle and let  $D$ ,  $E$  and  $F$  be the midpoints of sides  $\overline{BC}$ ,  $\overline{CA}$  and  $\overline{AB}$ , respectively. Let  $X \neq A$  be the intersection of  $AD$  with the circumcircle of  $ABC$ . Let  $\Omega$  be the circle through  $D$  and  $X$ , tangent to the circumcircle of  $ABC$ . Let  $Y$  and  $Z$  be the intersections of the tangent to  $\Omega$  at  $D$  with the perpendicular bisectors of segments  $\overline{DE}$  and  $\overline{DF}$ , respectively. Let  $P$  be the intersection of  $YE$  and  $ZF$  and let  $G$  be the centroid of  $ABC$ . Show that the tangents at  $B$  and  $C$  to the circumcircle of  $ABC$  and the line  $PG$  are concurrent.

*(Jakob Jurij Snoj)*

**Problem 3.** Let  $\mathbb{N}$  denote the set of all positive integers. Find all functions  $f : \mathbb{N} \rightarrow \mathbb{N}$  such that

$$x^2 - y^2 + 2y(f(x) + f(y))$$

is a square of an integer for all positive integers  $x$  and  $y$ .

*(Ivan Novak)*

**Problem 4.** Find all positive integers  $d$  for which there exist polynomials  $P(x)$  and  $Q(x)$  with real coefficients such that degree of  $P$  equals  $d$  and

$$P(x)^2 + 1 = (x^2 + 1)Q(x)^2.$$

*(Ivan Novak)*

*Time: 240 minutes.*

*Each problem is worth 10 points.*

*The use of calculators or any other instruments except rulers and compasses is not permitted.*

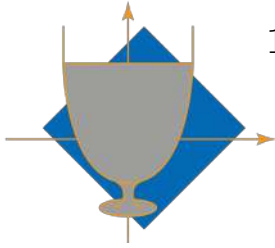

# 10<sup>TH</sup> EUROPEAN MATHEMATICAL CUP

11<sup>th</sup> December 2021 - 19<sup>th</sup> December 2021

Senior Category



## Problems and Solutions

**Problem 1.** Alice drew a regular 2021-gon in the plane. Bob then labelled each vertex of the 2021-gon with a real number, in such a way that the labels of consecutive vertices differ by at most 1. Then, for every pair of non-consecutive vertices whose labels differ by at most 1, Alice drew a diagonal connecting them. Let  $d$  be the number of diagonals Alice drew. Find the least possible value that  $d$  can obtain.

(Ivan Novak)

**First Solution.** Consider the following labelling of the vertices, where the  $i$ -th number of the 2021-tuple below is the label of the  $i$ -th vertex:

$$(0.5, 1.5, 2.5, \dots, 1009.5, 1010.5, 1010, 1009, 1008, \dots, 2, 1).$$

It's easy to see that in this case, Alice will draw 2018 diagonals, those connecting the vertices whose pairs of labels are  $\{1.5, 1\}$ ,  $\{2.5, 2\}$ ,  $\dots$ ,  $\{1009.5, 1009\}$  and  $\{1.5, 2\}$ ,  $\{2.5, 3\}$ ,  $\dots$ ,  $\{1009.5, 1010\}$ .

**3 points.**

We now prove that 2018 is the minimum amount of diagonals Alice could have drawn. Call any labelling of a convex  $n$ -gon which satisfies the condition that consecutive vertices have labels which differ by at most 1 a *sweet* labelling, and also call the corresponding  $n$ -gon *sweet*.

We will prove by mathematical induction that for every  $n \geq 3$ , in any sweet labelling of an  $n$ -gon, there are at least  $n - 3$  pairs of nonconsecutive vertices whose labels differ by at most 1. The claim is obvious for  $n = 3$ . Suppose that the claim is true for some positive integer  $n$ .

Consider a sweet labelling of some  $n + 1$ -gon  $P$ . Consider a vertex  $v$  with the maximum label,  $L$ . Then both of its neighbouring vertices have labels in the set  $[L - 1, L]$ , which means that their labels differ by at most 1.

**1 point.**

Then the  $n$ -gon  $P'$  obtained from  $P$  by erasing  $v$  and connecting its neighbouring vertices is also sweet.

**2 points.**

Applying the inductive hypothesis on it, there are at least  $n - 3$  pairs of nonconsecutive vertices of  $P'$  whose labels differ by at most 1. Adding the pair of neighbours of  $v$ , we conclude that  $P$  has at most  $n - 2$  pairs of such vertices. This completes the step of the induction.

**4 points.**

**Second Solution.** The example which achieves the desired bound is the same as in the previous solution.

**3 points.**

Let the labels of the vertices of the 2021-gon be  $v_1, \dots, v_{2021}$ , where we assume the labels to be ordered so that  $v_1 \leq \dots \leq v_{2021}$ . Note that this is not necessarily the order in which the values appear on the 2021-gon.

We claim that  $|v_i - v_{i+2}| \leq 1$ , for all  $i = 1, 2, \dots, 2019$ .

Assume for the sake of contradiction that there exists an  $i \in \{1, 2, \dots, 2019\}$  for which  $v_{i+2} - v_i > 1$ . Start a circular walk around the 2021-gon, going from the vertex which has the value  $v_1$ , visiting all of the vertices one by one, and returning back to the starting vertex. Doing so visits the values  $v_1, \dots, v_{2021}$  in a certain permuted order, starting and ending on  $v_1$ .

We look at the first time during the walk when we step on a value whose index is greater than or equal to  $i + 2$ . Let this index be  $j \geq i + 2$ . Let's say that on the previous step, we were on value  $v_b$ , where  $b \leq i + 1$ . Note that if  $b \leq i$ , then  $v_j - v_b \geq v_{i+2} - v_i > 1$ , so it must be the case that  $b = i + 1$ . Next, we look at the first time we return to an index which is smaller than or equal to  $i$ . Such an index must exist since we eventually return back to  $v_1$ , and we'll denote it by  $k$ . A similar argument as for  $v_j$  shows that in the step before reaching  $v_k$ , we must have been on index  $b$ . This is a contradiction as no vertex can be visited more than once, except for the one we started with.

**5 points.**

We now have  $|v_i - v_j| \leq 1$ , for all  $i = 3, \dots, 2019$  and  $j \in \{i - 1, i - 2, i + 1, i + 2\}$ ,  $|v_1 - v_i| \leq 1$  for  $j \in \{2, 3\}$  and  $|v_j - v_{2021}| \leq 1$  for  $j \in \{2019, 2020\}$ , which gives at least  $\frac{1}{2}(2 + 3 + 4 \cdot 2017 + 3 + 2) - 2021 = 2018$  diagonals.

**2 points.**

**Third Solution.** The example which achieves the desired bound is the same as in the previous solution.

**3 points.**

Note that

We label the vertices  $v_1, v_2, \dots, v_{2021}$ , and, respectively, their labels  $x_1, x_2, \dots, x_{2021}$  and view the indices modulo 2021. We'll say vertices  $(v_i, v_j)$  are a *nigh* pair if their labels differ by at most 1.

Without loss of generality, let 1 and  $g$  be the indices among  $\{1, 2, \dots, 2021\}$  of the vertices with the smallest and greatest label, respectively. Without loss of generality we can also assume  $g \leq 1011$  since we can otherwise mirror the 2021-gon. Additionally, we will assume that  $g \geq 4$ , and the cases  $g = 3$  and  $g = 2$  are dealt with separately. We make use of the following lemmas.

**Lemma 1.** *For every  $1 < k < g$ , there are at least two indices  $g \leq i, j \leq 2022$  such that  $(v_k, v_i)$  and  $(v_k, v_j)$  are pairs of nigh vertices. Similarly, for every  $g < k < 2022$ , there are at least two indices  $1 \leq i, j \leq g$  such that  $(v_k, v_i)$  and  $(v_k, v_j)$  are pairs of nigh vertices.*

*Proof.* As the statement is obviously symmetric, we will only prove the first half. Let  $m$  and  $M$  be the smallest and the biggest label, respectively. If  $x_k \leq m + 1$ ,  $v_{2021}$  and  $v_1$  satisfy the condition of the lemma. Similarly, if  $x_k \geq M - 1$ ,  $v_g$  and  $v_{g+1}$  satisfy the condition of the lemma. Otherwise, there are at least two indices within the desired range with labels in  $[x - 1, x + 1]$  due to the Intermediate Value Theorem. Namely, if we imagine jumping along the vertices from  $v_1$  do  $v_g$ , at the vertex  $v_1$  the label is less than  $x - 1$  and at the vertex  $v_g$  the label is greater than  $x + 1$ . Then at some point in between we must have been at a vertex whose label is from  $[x - 1, x)$  and at a vertex whose label is from  $[x, x + 1)$ .  $\square$

**4 points.**

**Lemma 2.** At most one of the vertices  $v_{2021}$  and  $v_2$  and at most one of the vertices  $v_{g-1}$  and  $v_{g+1}$  can be elements of three nigh pairs.

*Proof.* Clearly, due to Lemma 1, both  $v_{2021}$  and  $v_2$  are elements of at least three nigh pairs. Assume both vertices are elements of exactly three nigh pairs. Assume that  $x_{2021} \leq x_2$ . It follows that  $x_2 - 1 \leq x_1 \leq x_{2020} \leq x_{2021} + 1 \leq x_2 + 1$ , therefore,  $v_{2020}, v_{2021}, v_1$  and  $v_3$  are four vertices forming nigh pairs with  $v_2$ , a contradiction. We treat the other cases analogously.  $\square$

**2 points.**

Finally, due to Lemma 1, each vertex not neighbouring with  $g$  or 1 forms at least 4 nigh pairs. The vertices  $v_1$  and  $v_g$  form at least 2 nigh pairs and at most two of their neighbouring vertices form 3 nigh pairs. The minimal number of nigh pairs is therefore  $\frac{1}{2} \cdot (2017 \cdot 4 + 2 \cdot 3 + 2 \cdot 2) = 4039$ .

**1 point.**

Assume  $g \leq 3$ . If  $g = 2$ , all the pairs of vertices are nigh as their labels are all in the set  $[x_1, x_2]$ . If  $g = 3$ , each vertex forms a nigh pair with at least one of  $v_1$  or  $v_3$ . Without loss of generality, more than half of the remaining vertices form nigh pairs with  $v_1$ . But then all of those vertices are nigh as well, so there are at least  $\binom{1015}{2} > 4039$  nigh pairs, making this case suboptimal as well.

**0 points.**

**Notes on marking:**

- Points from different solutions are not additive. Student's score should be the maximum of points scored over all solutions.
- Miscounting the number  $d$  in the optimal example or making a similar minor mistake in that part should be awarded **2 points** out of possible **3** for that part of the solution.
- In the first solution, just stating the idea of induction is worth no points on its own.
- In the third solution, dealing with the case  $g \leq 3$  is worth no points on its own. However, a contestant who doesn't comment these cases can get at most **9 points** for their solution.

**Problem 2.** Let  $ABC$  be a triangle and let  $D, E$  and  $F$  be the midpoints of sides  $\overline{BC}, \overline{CA}$  and  $\overline{AB}$ , respectively. Let  $X \neq A$  be the intersection of  $AD$  with the circumcircle of  $ABC$ . Let  $\Omega$  be the circle through  $D$  and  $X$ , tangent to the circumcircle of  $ABC$ . Let  $Y$  and  $Z$  be the intersections of the tangent to  $\Omega$  at  $D$  with the perpendicular bisectors of segments  $\overline{DE}$  and  $\overline{DF}$ , respectively. Let  $P$  be the intersection of  $YE$  and  $ZF$  and let  $G$  be the centroid of  $ABC$ . Show that the tangents at  $B$  and  $C$  to the circumcircle of  $ABC$  and the line  $PG$  are concurrent.

(Jakob Jurij Snoj)

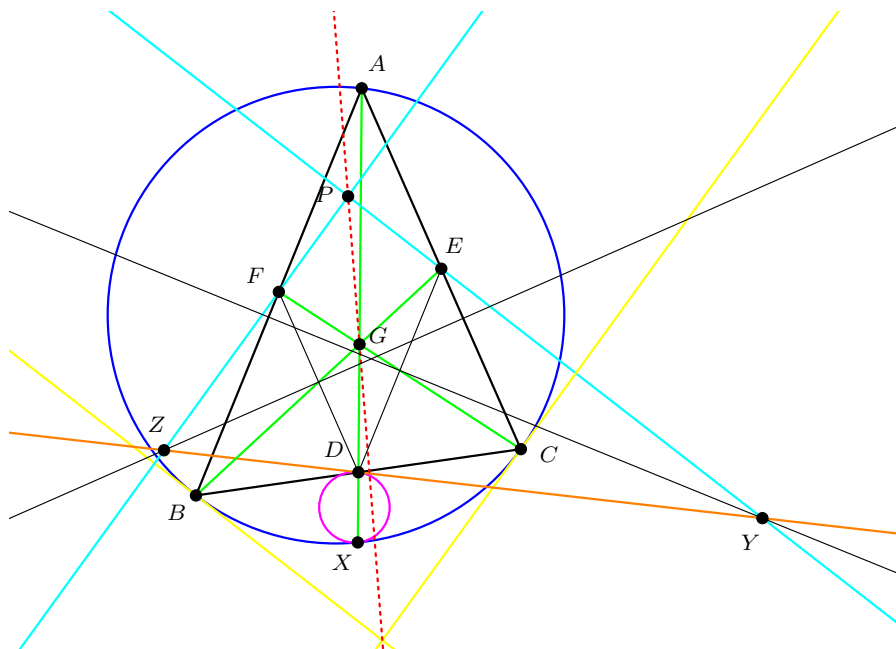

**First Solution.** Due to the collinearity of  $A, X$  and  $D$ , there is a homothety at  $X$  sending the circumcircle of  $ABC$  to  $\Omega$ . This homothety also sends the tangent at  $A$  to the circumcircle of  $ABC$  to the tangent at  $D$  of  $\Omega$ .

**1 point.**

The homothety in  $G$  with ratio  $-\frac{1}{2}$  sends the circumcircle of  $ABC$  to its nine-point circle and the tangent at  $A$  to the circumcircle to the tangent at  $D$  to the nine-point circle. These tangents are therefore parallel. It follows that  $\Omega$  and the nine-point circle of  $ABC$  share a tangent at  $D$ .

**2 points.**

As  $Y$  and  $Z$  lie on the perpendicular bisectors of  $DE$  and  $DF$ , respectively, it follows that  $|YD| = |YE|$  and  $YE$  is also tangent to the nine-point circle of  $ABC$  - similarly,  $ZF$  is also tangent to this circle. We conclude that the nine-point circle of  $ABC$  is the incircle of  $PYZ$ .

**3 points.**

Finally, the homothety at  $G$  sending the circumcircle of  $ABC$  to its nine-point circle sends the tangents through  $A, B$  and  $C$  to the circumcircle of  $ABC$  respectively to the tangents at  $D, E$  and  $F$  to the nine-point circle of  $ABC$ . It, therefore, sends the intersection of tangents at  $B$  and  $C$  to the circumcircle of  $ABC$  to the point  $P$ , thus proving the desired collinearity.

**4 points.**

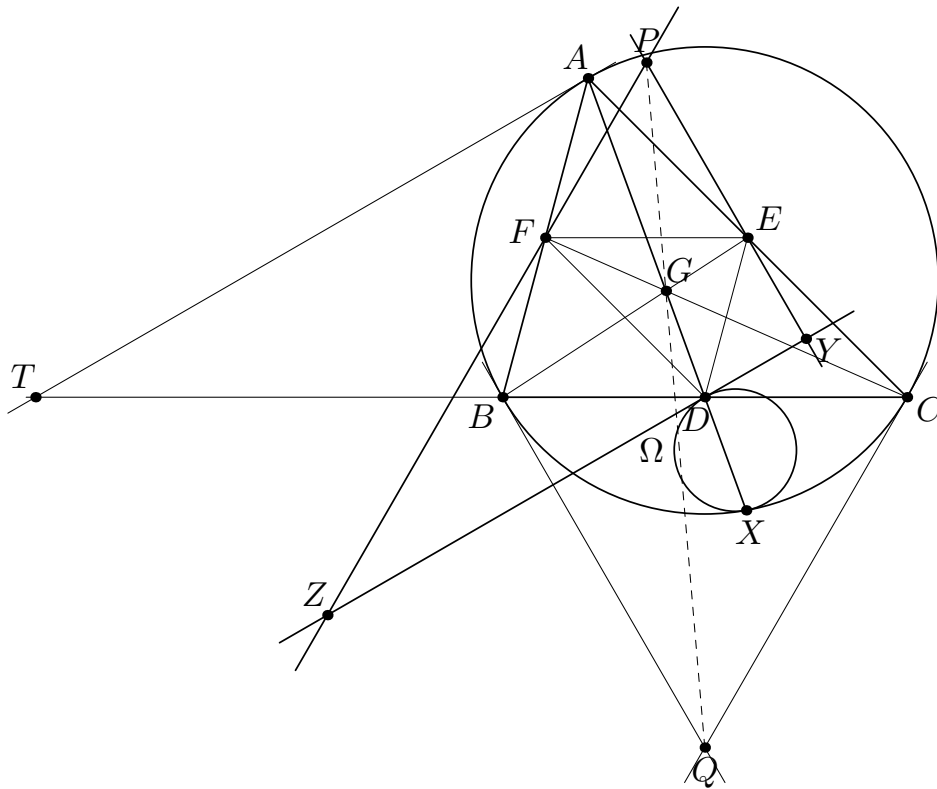

**Second Solution.** As in the previous solution, we prove that the tangent at  $D$  to  $\Omega$  is parallel to the tangent at  $A$  to the circumcircle of  $ABC$ .

**1 point.**

Let  $\angle BAC = \alpha$ ,  $\angle ABC = \beta$ ,  $\angle ACB = \gamma$ . Let  $Q$  be the intersection of the tangents at  $B$  and  $C$  to the circumcircle of  $ABC$ . It now suffices to prove that  $G$  lies on  $PQ$ .

**0 points.**

Let  $T$  be the point on  $BC$  such that the line  $TA$  is tangent to the circumcircle of  $ABC$  at  $A$ . By the *tangent-chord theorem*, we have  $\angle TAB = \gamma$ , which implies  $\angle ATB = \beta - \gamma$ . Since  $ZY \parallel TA$  and  $\angle YDC = \angle ATB = \beta - \gamma$ .

**1 point.**

By definition of  $Y$ , we have  $|EY| = |DY|$ . Since  $DE$  is a midline of  $ABC$ , we have  $\angle EDC = \angle ABC = \beta$ . Thus

$$\angle DEY = \angle EDY = \angle EDC - \angle YDC = \beta - (\beta - \gamma) = \gamma.$$

**2 points.**

Furthermore, note that  $\angle BED + \angle DBE = \angle EDC = \beta$ , and  $\angle QBC = \alpha$ , by the *tangent-chord theorem*. This implies

$$\angle QBE + \angle BEY = (\angle QBC + \angle DBE) + (\angle BED + \angle DEY) = \alpha + \beta + \gamma = 180^\circ$$

so  $QB \parallel PE$ . By analogous reasoning we conclude that  $QC \parallel PF$ .

**2 points.**

Since  $EF$  is a midline of  $ABC$ , we have that the sides  $EP$ ,  $PF$ ,  $EF$  of triangle  $PEF$  are parallel to the sides  $QB$ ,  $QC$ ,  $BC$  of triangle  $QBC$ , respectively. Those triangles are not congruent because  $EF = \frac{BC}{2}$ , so there exists a homothety which maps  $PEF$  to  $QBC$ . The centre of the homothety is the intersection of  $BE$ ,  $CF$ , and  $PQ$ , which implies that  $G$  lies on  $PQ$  and we are done.

**4 points.**

**Notes on marking:**

- In the second solution, once we obtain  $\angle DEY = \angle EDY = \gamma$ , we can conclude that  $YE$  is tangent to the circumcircle of  $DEF$  and finish as in the first solution.
- The final **4 points** in either solution can only be awarded if the student correctly proves the other steps of the problem. Otherwise, a contestant can only obtain up to **2 points** for this part of the solution.
- No points are deducted if the student fails to argue that  $\triangle PYZ$  and the triangle formed by the tangents through  $A$ ,  $B$  and  $C$  to the circumcircle of  $ABC$  are not congruent.
- Analytic approaches are only awarded points if their results are correctly interpreted by geometric means.

**Problem 3.** Let  $\mathbb{N}$  denote the set of all positive integers. Find all functions  $f : \mathbb{N} \rightarrow \mathbb{N}$  such that

$$x^2 - y^2 + 2y(f(x) + f(y))$$

is a square of an integer for all positive integers  $x$  and  $y$ .

(Ivan Novak)

**First Solution.** Throughout the solution, let  $P(a, b)$  denote the assertion " $a^2 - b^2 + 2b(f(a) + f(b))$  is a perfect square".

Let  $p$  be a prime. Then  $P(p, p)$  implies  $4pf(p)$  is a perfect square, which implies  $p \mid f(p)$ .

1 point.

Let  $y$  be any positive integer, and let  $p$  be any prime.  $P(p, y)$  implies  $p^2 + 2yf(p) + 2yf(y) - y^2$  is a perfect square. Taking the assertion modulo  $p$ , it follows that  $2yf(y) - y^2$  is a quadratic residue modulo  $p$ . It is a well known fact that if a positive integer is a quadratic residue modulo all primes, it must be a perfect square. We conclude that  $2yf(y) - y^2$  is a perfect square for all  $y \in \mathbb{N}$ .

3 points.

Define  $g(y)$  to be  $\sqrt{2yf(y) - y^2}$ .

$P(1, y)$  implies  $1 - y^2 + 2yf(1) + 2yf(y) = g(y)^2 + 2yf(1) + 1$  is a perfect square, and since

$$g(y)^2 + 2yf(1) + 1 > g(y)^2,$$

we have a following chain of inequalities:

$$\begin{aligned} g(y)^2 + 2yf(1) + 1 &\geq (g(y) + 1)^2 \implies 2yf(1) + 1 \geq 2g(y) + 1 \implies \\ yf(1) &\geq g(y) \implies y^2 f(1)^2 \geq 2yf(y) - y^2 \implies \frac{f(1)^2 + 1}{2} y \geq f(y). \end{aligned}$$

1 point.

Since  $p \mid f(p)$  and  $\frac{f(p)}{p} \leq \frac{f(1)^2 + 1}{2}$  for any prime  $p$ , it follows from Pigeonhole principle that there exists a positive integer  $a$  such that  $f(p) = ap$  for infinitely many primes  $p$ .

2 points.

Let  $p$  be any prime such that  $f(p) = ap$  and let  $n$  be any positive integer.  $P(p, n)$  implies

$$p^2 - n^2 + 2nap + 2nf(n) = (p + na)^2 - n^2 a^2 - n^2 + 2nf(n)$$

is a perfect square.

However, this means that  $2nf(n) - n^2 - n^2 a^2$  can be written as a difference of squares in infinitely many ways, which is only possible if it equals 0. Thus,  $2nf(n) = n^2 a^2 + n^2$ , or, equivalently,  $f(n) = \frac{n(a^2 + 1)}{2}$  for all  $n \in \mathbb{N}$ . This also implies  $\frac{a^2 + 1}{2} = a$ , which gives us  $a = 1$ .

Therefore,  $f(n) = n$  for all  $n \in \mathbb{N}$ . It can be easily checked that the identity function is indeed a solution.

3 points.

**Second Solution.** Similarly as in the first solution, we conclude that  $p \mid f(p)$ . Also, from  $P(4p, 4p)$ , we also conclude that  $p \mid f(4p)$  for every odd prime  $p$ .

1 point.

Fix an odd prime number  $p$ , and let  $A = \frac{f(p)}{p}$  and  $B = \frac{f(4p)}{p}$ .

Now, from  $P(4p, p)$ , we have that  $15p^2 + 2p^2(A + B)$  is a square, which means  $15 + 2(A + B)$  is also a square. Multiplying by 4 yields the fact that  $60 + 8(A + B)$  is a square.

From  $P(p, 4p)$ , we have that  $-15p^2 + 8p^2(A + B)$  is a square, which means  $-15 + 8(A + B)$  is a square.

We then have

$$75 = 60 + 8(A + B) - (-15 + 8(A + B)).$$

Since there are finitely many ways to write 75 as a difference of two squares, we conclude that  $A + B$  can take only finitely many different values as  $p$  ranges over all primes. The same is true for  $A$ .

4 points.

Therefore, by Pigeonhole principle, there exists a positive integer  $a$  such that  $f(p) = ap$  for infinitely many primes  $p$ .

2 points.

The problem can now be finished the same way as in the first solution.

**3 points.**

**Notes on marking:**

- Both solutions follow a similar structure. In the first part, a constant  $a$  is found such that  $f(p) = ap$  for infinitely many primes  $p$ , and in the second part the problem is completed using the first fact. The points from different solutions are not additive.
- In the first solution, it is not expected from the students to prove the key lemma about quadratic residues that is used; it suffices to state it. On the other hand, merely stating the lemma is not worth any points on its own.
- If a student solves the problem under the assumption that  $f(p) = ap$  for infinitely many  $p$ , but they don't prove this fact, they can get at most **1 point** out of the last **3 points**.
- In the second solution, if a student discusses  $P(1, 4)$  and  $P(4, 1)$  similarly to how  $P(p, 4p)$  and  $P(4p, p)$  are discussed, and concludes that  $f(1)$  and  $f(4)$  can take on finitely many different values, they should get **1 point** out of **4** for that part of the solution.

**Problem 4.** Find all positive integers  $d$  for which there exist polynomials  $P(x)$  and  $Q(x)$  with real coefficients such that degree of  $P$  equals  $d$  and

$$P(x)^2 + 1 = (x^2 + 1)Q(x)^2.$$

(Ivan Novak)

**First Solution.**

$$P(x)^2 + 1 = (x^2 + 1)Q(x)^2 \tag{1}$$

Let  $P$  and  $Q$  be polynomials satisfying the conditions. Note that the degree of the left hand side in (1) the equality is  $2d$ , and the degree of the right hand side is  $2 + 2 \deg Q$ , which implies  $\deg Q = d - 1$ .

Suppose that  $r$  is a real root of  $Q$ . Then  $P(r)^2 + 1 = 0$ , which is clearly impossible. We conclude that  $Q$  has no real roots. Since  $Q$  has real coefficients, we conclude that  $Q$  has even degree since its roots must come in conjugate pairs. Thus,  $d$  must be odd.

**1 point.**

Now we prove that for any odd  $d$ , there exist polynomials satisfying the conditions. Let  $\mathbb{R}[x, \sqrt{x^2 + 1}]$  be the set of all functions of the form  $A + B\sqrt{x^2 + 1}$ , where  $A$  and  $B$  are polynomials with real coefficients. Note that each element of  $\mathbb{R}[x, \sqrt{x^2 + 1}]$  can be uniquely associated with a pair of polynomials  $(A, B)$ . Consider a function  $n : \mathbb{R}[x, \sqrt{x^2 + 1}] \rightarrow \mathbb{R}$  defined by

$$n(A + B\sqrt{x^2 + 1}) = A^2 - (x^2 + 1)B^2$$

for all real polynomials  $A$  and  $B$ . Note that the equality (1) is equivalent to the equality

$$n(P + \sqrt{x^2 + 1}Q) = -1.$$

**1 point.**

Note that

$$n((A + \sqrt{x^2 + 1}B)(C + \sqrt{x^2 + 1}D)) = n(AC + (x^2 + 1)BD + \sqrt{x^2 + 1}(AD + BC)) = (AC + (x^2 + 1)BD)^2 - (x^2 + 1)(AD + BC)^2.$$

On the other hand,

$$n(A + \sqrt{x^2 + 1}B)n(C + \sqrt{x^2 + 1}D) = (A^2 - (x^2 + 1)B^2)(C^2 - (x^2 + 1)D^2).$$

It can easily be checked that the two expressions are equal. Hence, the function  $n$  is multiplicative.

**1 point.**

Note that  $n(x + \sqrt{x^2 + 1}) = -1$ .

**1 point.**

Then, using the multiplicative property,  $n((x + \sqrt{x^2 + 1})^d) = -1$  as well. Let  $(x + \sqrt{x^2 + 1})^d = P + \sqrt{x^2 + 1}Q$  for some polynomials  $P$  and  $Q$ . By binomial theorem, we have

$$P + \sqrt{x^2 + 1}Q = (x + \sqrt{x^2 + 1})^d = \sum_{j \text{ odd}} \binom{d}{j} x^{d-j} (x^2 + 1)^{\frac{d-j}{2}} + \sum_{j \text{ even}} \binom{d}{j} x^j (x^2 + 1)^{\frac{d-1-j}{2}} \sqrt{x^2 + 1}.$$

It's now easy to see that  $P$  has degree  $d$ , since it is a sum of polynomials which have degree  $d$  and positive leading coefficients, and  $P$  and  $Q$  satisfy the starting equality. Thus, all odd positive integers are solutions.

**6 points.**

**Second Solution.**

$$P(x)^2 + 1 = (x^2 + 1)Q(x)^2 \tag{2}$$

Similarly as in the first solution, we conclude that  $d$  needs to be odd.

**1 point.**

Let us now prove that for every odd  $d$  such polynomials  $P(x)$  and  $Q(x)$  exist. Fix an odd positive integer  $d$ . Observing the roots of polynomials  $P(x)$  and  $Q(x)$ , we can easily see from (2) that  $P(x)$  and  $Q(x)$  don't have a common root. Differentiating (2), we get :

$$P'(x)P(x) = x \cdot Q(x)^2 + (x^2 + 1) \cdot Q'(x)Q(x) = Q(x) (x \cdot Q(x) + (x^2 + 1) \cdot Q'(x)). \tag{3}$$

Since  $P(x)$  and  $Q(x)$  don't have common roots, from (3) we conclude that  $Q(x)$  must divide  $P'(x)$ . Since they have the same degree, there must exist a real number  $u$  such that  $uP'(x) = Q(x)$ .

**1 point.**

Comparing coefficients in (2), we get that  $u$  must be  $\frac{1}{d}$  or  $-\frac{1}{d}$ .

**1 point.**

We'll take  $u = \frac{1}{d}$ . Plugging in  $Q(x) = P'(x)/d$  in (3), we get

$$P(x) = \frac{1}{d} \left( \frac{1}{d}x \cdot P'(x) + \frac{1}{d}(x^2 + 1)P''(x) \right). \quad (4)$$

We will now find all polynomials  $P$  of degree  $d$  which satisfy (4). Note that, by multiplying both sides with  $P'(x)$  and integrating, each of these polynomials satisfies the equation  $P(x)^2 + C = (x^2 + 1)\frac{(P'(x))^2}{d^2}$  for some  $C \in \mathbb{R}$ .

Denote  $P(x) = \sum_{i=0}^d a_i x^i$ . Then  $P'(x) = \sum_{i=1}^d i a_i x^{i-1}$  and  $P''(x) = \sum_{i=2}^d i(i-1)a_i x^{i-2}$ . Writing out the coefficients in (4), we get

$$\sum_{i=0}^d a_i x^i = \frac{1}{d^2} \left( \sum_{i=1}^d i^2 a_i x^i + \sum_{i=2}^d i(i-1)a_i x^{i-2} \right)$$

Comparing the coefficients of  $x^k$  for all  $k$  on the left hand side and the right hand side of the above equation for  $k \geq 0$ , we get:

$$a_{d-1} = \frac{1}{d^2} ((d-1)^2 a_{d-1}) \quad \text{which implies} \quad a_{d-1} = 0,$$

and also

$$a_k = \frac{1}{d^2} (k^2 a_k + (k+2)(k+1)a_{k+2}) \quad \text{which can be rewritten as}$$
$$a_{k+2} = \frac{d^2 - k^2}{(k+2)(k+1)} \cdot a_k \quad \text{for all} \quad 0 \leq k \leq d-2.$$

**1 point.**

From here, we now have that  $a_k = 0$  for all even  $0 \leq k \leq d-2$  and that for all odd  $0 \leq k \leq d-2$ , we have  $a_k = q_k a_1$  for some nonzero real coefficient  $q_k$  which is uniquely determined by the above recursion.

**1 point.**

It's easy to see that any such choice of coefficients  $(a_k)_k$  with  $a_1 \neq 0$  gives a solution to (4) which has degree  $d$ .

As we've already said, any solution to (4) is a solution to  $P(x)^2 + C = (x^2 + 1)\frac{(P'(x))^2}{d^2}$  for some  $C \in \mathbb{R}$ . Considering the coefficient alongside  $x^0$  in both sides and noting  $a_0 = 0$ , we get  $C = a_1^2/d^2$ . Thus, taking a solution with  $a_1 = d$ , we get the solution to  $P(x)^2 + 1 = (x^2 + 1)\frac{(P'(x))^2}{d^2}$ , which proves that every odd  $d$  is a solution to the problem.

**5 points.**

**Third Solution.**

$$P(x)^2 + 1 = (x^2 + 1)Q(x)^2 \quad (5)$$

Similarly as in the first solution, we conclude that  $d$  needs to be odd.

**1 point.**

Note that  $d = 1$  is a solution, taking  $P(x) = x$  and  $Q(x) = 1$ . Henceforth assume  $d \geq 3$ .

From  $x^2 + 1 \mid P(x)^2 + 1$  we get  $x^2 + 1 \mid P(x)^2 - x^2 \implies x^2 + 1 \mid (P(x) - x)(P(x) + x)$ . It is not hard to see that the irreducible polynomial  $x^2 + 1$  divides exactly one of the two factors. We can replace  $P$  by  $-P$ , so without loss of generality it is safe to assume that  $P(x) = A(x)(x^2 + 1) + x$  for some real polynomial  $A$ . If we put this in (5), we obtain

$$(A(x) \cdot x + 1)^2 + A(x)^2 = Q(x)^2.$$

We will find real polynomials  $\alpha$  and  $\beta$  such that  $A(x) = 2\alpha(x)\beta(x)$ ,  $Q(x) = \alpha(x)^2 + \beta(x)^2$ ,  $xA(x) + 1 = \alpha(x)^2 - \beta(x)^2$  and  $\deg \alpha + \deg \beta = d - 2$ . Note that then  $A(x)$  and  $Q(x)$  satisfy the conditions due to the identities for Pythagorean triples.

**2 points.**

We thus need to find solutions to the equation

$$2x\alpha(x)\beta(x) + 1 = \alpha(x)^2 - \beta(x)^2 \quad (6)$$

where  $\alpha, \beta \in \mathbb{R}[x]$  are polynomials with real coefficients. Notice that  $(\alpha, \beta) = (1, -2x)$  is a pair of solutions.

**1 point.**

If we look at (6) as a quadratic equation in  $\alpha$  we have

$$\alpha^2 - \alpha \cdot 2x\beta + 1 - \beta^2 = 0.$$

Roots  $\alpha_1, \alpha_2$  must then satisfy  $\alpha_1 + \alpha_2 = 2x\beta$ . It is now easily verified that if  $(\alpha, \beta)$  is a pair of polynomials which satisfy (6), then  $(\beta, 2x\beta - \alpha)$  is another such pair.

**1 point.**

Thus starting with solution  $(\alpha_0, \beta_0) = (1, -2x)$ , we can recursively generate a sequence of solutions

$$(\alpha_{i+1}, \beta_{i+1}) = (\beta_i, 2x\beta_i - \alpha_i).$$

The degrees of  $(\alpha_i, \beta_i)_{i \geq 0}$  now follow the pattern

$$(0, 1), (1, 2), (2, 3), (3, 4) \dots$$

More precisely,  $\deg \alpha_i = i$ ,  $\deg \beta_i = i + 1$  for all  $i \geq 0$ .

But then, if  $d = 2i + 1$  for some  $i \geq 0$ , the pair  $(\alpha_i, \beta_i)$  gives a pair  $(A, Q) = (2\alpha\beta, \alpha^2 + \beta^2)$  such that  $(xA(x) + 1)^2 + A(x)^2 = Q(x)^2$  and  $\deg A = i + (i - 1) = d - 2$ . Then, taking  $P(x) = (x^2 + 1)A(x) + x$  yields a pair  $(P, Q)$  satisfying the original equation such that  $\deg P = d$ . We conclude that every odd  $d$  is a solution.

**5 points.**

**Notes on marking:**

- Points from different marking schemes are not additive.



# Statistics of the 10th European Mathematical Cup

11th Dec 2021 - 19th Dec 2021



## Junior Category

#	J1	J2	J3	J4	Graph J1	Graph J2	Graph J3	Graph J4
0	104	154	225	265				
1	22	17	30	0				
2	11	4	0	0				
3	2	3	1	0				
4	4	1	0	0				
5	2	0	0	0				
6	6	2	0	0				
7	9	0	0	0				
8	5	1	0	0				
9	15	1	1	0				
10	86	83	9	1				
$\Sigma$	266	266	266	266				
$\mu$	4.55	3.37	0.50	0.04				
$\sigma$	4.55	4.58	1.90	0.61				

## Senior Category

#	S1	S2	S3	S4	Graph S1	Graph S2	Graph S3	Graph S4
0	73	136	151	208				
1	8	3	67	12				
2	11	2	1	2				
3	14	2	0	4				
4	2	1	7	0				
5	5	3	1	1				
6	6	1	0	0				
7	6	3	0	0				
8	2	2	0	0				
9	31	10	1	6				
10	78	73	8	3				
$\Sigma$	236	236	236	236				
$\mu$	5.33	3.79	0.81	0.50				
$\sigma$	4.41	4.68	1.99	1.86				

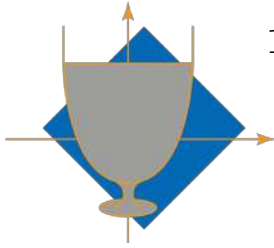

# 11<sup>TH</sup> EUROPEAN MATHEMATICAL CUP

10<sup>th</sup> December 2022 - 18<sup>th</sup> December 2022

Junior Category



**Problem 1.** Find all positive integers  $n$  for which there exist three positive divisors  $a, b, c$  of  $n$  such that  $a > b > c$  and

$$a^2 - b^2, b^2 - c^2, a^2 - c^2$$

are also divisors of  $n$ .

(Kims Georgs Pavlovs)

**Problem 2.** Find all pairs of positive real numbers  $(x, y)$  such that  $xy$  is an integer and

$$x + y = \lfloor x^2 - y^2 \rfloor.$$

*Remark:* For a real number  $z$ , we denote by  $\lfloor z \rfloor$  the greatest integer not greater than  $z$ . Some examples are  $\lfloor 17 \rfloor = 17$ ,  $\lfloor 8.2 \rfloor = 8$  and  $\lfloor -5.4 \rfloor = -6$ .

(Ivan Novak)

**Problem 3.** Let  $ABC$  be an acute-angled triangle with  $|BC| < |AC|$ . Let  $I$  be the incenter and  $\tau$  the incircle of  $ABC$ , which touches  $BC$  and  $AC$  at points  $D$  and  $E$ , respectively. The point  $M$  is on  $\tau$  such that  $BM$  is parallel to  $DE$  and  $M$  and  $B$  are on the same side of the angle bisector of  $\angle BCA$ . Let  $F$  and  $H$  be the intersections of  $\tau$  with  $BM$  and  $CM$  different from  $M$ , respectively. Let  $J$  be a point on the line  $AC$  such that  $JM$  is parallel to  $EH$ . Let  $K$  be the intersection of  $JF$  and  $\tau$  different from  $F$ .

Prove that the lines  $ME$  and  $KH$  are parallel.

(Steve Vo Dinh)

**Problem 4.** Let  $X = \{1, 2, 3, \dots, 300\}$ . A collection  $F$  of distinct (not necessarily non-empty) subsets of  $X$  is *lovely* if for any three (not necessarily distinct) sets  $A, B, C$  in  $F$ , at most three out of the following eight sets are non-empty:

$$\begin{array}{cccc} A \cap B \cap C, & \bar{A} \cap B \cap C, & A \cap \bar{B} \cap C, & A \cap B \cap \bar{C}, \\ \bar{A} \cap \bar{B} \cap C, & \bar{A} \cap B \cap \bar{C}, & A \cap \bar{B} \cap \bar{C}, & \bar{A} \cap \bar{B} \cap \bar{C}, \end{array}$$

where  $\bar{S}$  denotes the set of all elements of  $X$  that are not in  $S$ .

What is the greatest possible number of sets in a lovely collection?

(Miroslav Marinov)

*Time: 240 minutes.*

*Each problem is worth 10 points.*

*The use of calculators or any other instruments except rulers and compasses is not permitted.*

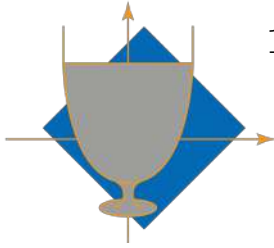

# 11<sup>TH</sup> EUROPEAN MATHEMATICAL CUP

10<sup>th</sup> December 2022 - 18<sup>th</sup> December 2022

Junior Category



## Problems and Solutions

**Problem 1.** Find all positive integers  $n$  for which there exist three positive divisors  $a, b, c$  of  $n$  such that  $a > b > c$  and

$$a^2 - b^2, b^2 - c^2, a^2 - c^2$$

are also divisors of  $n$ .

*(Kims Georgs Pavlovs)*

**Solution.** The answer is all positive integers  $n$  which are divisible by 60.

Suppose that  $n$  is divisible by 60. Let  $a = 4, b = 2, c = 1$ . Then  $a^2 - b^2 = 12, b^2 - c^2 = 3, a^2 - c^2 = 15$ . All six of those numbers are divisors of 60, so they're also divisors of  $n$ , so any  $n$  which is a multiple of 60 is indeed a solution.

**2 points.**

Now suppose that  $n$  is a number for which such  $a, b, c$  exist.

Some two numbers among  $a, b, c$  have the same parity. Without loss of generality let  $a$  and  $b$  be such numbers. Then  $a - b$  and  $a + b$  are both even, so 4 is a divisor of  $a^2 - b^2$ , so 4 also divides  $n$ . We conclude that  $n$  is divisible by 4.

**2 points.**

If any of  $a, b, c$  is divisible by 3, then  $n$  is also divisible by 3. Otherwise, two numbers among  $a, b, c$  give the same remainder upon division by 3. Without loss of generality let  $a$  and  $b$  be such numbers. Then 3 is a divisor of  $a^2 - b^2$ , so 3 also divides  $n$ . We conclude that in any case,  $n$  is divisible by 3.

**2 points.**

If any of  $a, b, c$  is divisible by 5, then  $n$  is also divisible by 5. Otherwise, none of  $a, b, c$  is divisible by 5. However, a square of a number which isn't divisible by 5 can only give remainder 1 or 4 upon division by 5.

Thus, some two numbers among  $a^2, b^2, c^2$  have the same remainder upon division by 5, so their difference is divisible by 5. We conclude that in any case,  $n$  is divisible by 5.

**3 points.**

Since 3, 4 and 5 all divide  $n$ , then their least common multiple, which is 60, also divides  $n$ .

**1 point.**

### Notes on marking:

- If a contestant proves that for some  $a > 1$ , all numbers of the form  $60 \cdot a \cdot k$  for  $k \in \mathbb{N}$  are solutions, they should be awarded **1 point** out of possible **2 points** for the first part of the solution.
- If a contestant proves that any  $n$  which is a solution is even, they should be awarded **1 point** out of possible **2 points** given for proving divisibility by 4.

**Problem 2.** Find all pairs of positive real numbers  $(x, y)$  such that  $xy$  is an integer and

$$x + y = \lfloor x^2 - y^2 \rfloor.$$

(Ivan Novak)

**First Solution.** Let  $(x, y)$  be a pair satisfying the problem's condition.

Note that  $x + y$  and  $xy$  are both positive integers, so  $(x - y)^2 = (x + y)^2 - 4xy$  is also a positive integer.

4 points.

Let  $D = (x - y)^2$ , and let  $a = x + y$ . We have

$$a = \lfloor a\sqrt{D} \rfloor,$$

where  $a$  and  $D$  are both positive integers. Furthermore, note that  $D = (x + y)^2 - 4xy$  gives remainder 0 or 1 upon division by 4. If  $D > 1$ , then  $D \geq 4$ , and  $\lfloor a\sqrt{D} \rfloor \geq \lfloor 2a \rfloor = 2a > a$ , which is a contradiction. Thus,  $D = 1$ .

3 points.

This means that  $x - y = 1$ . Since  $x + y = a$ , we must have

$$\begin{aligned} x &= \frac{a+1}{2}, \\ y &= \frac{a-1}{2} \end{aligned}$$

for some positive integer  $a$ . Since  $y > 0$ , we must have  $a > 1$ . Since  $xy$  is an integer,  $\frac{a^2-1}{4}$  must be an integer. Thus,  $a$  is odd. Let  $a = 2n + 1$  for some positive integer  $n$ . Then

$$(x, y) = (n + 1, n).$$

It's easy to check that all such pairs satisfy the problem's conditions.

3 points.

**Second Solution.** Note that  $x > y$  since  $x^2 - y^2 \geq x + y > 0$ .

Let  $a = x + y$  and  $b = xy$ . We then have  $x^2 - ax + b = 0$  and  $y^2 - ay + b = 0$ . This means that  $x$  and  $y$  are the roots of the polynomial  $t^2 - at + b$ , so, since  $x > y$ , we have

$$\begin{aligned} x &= \frac{a + \sqrt{D}}{2}, \\ y &= \frac{a - \sqrt{D}}{2}, \end{aligned}$$

where  $D = a^2 - 4b$  is a positive integer.

2 points.

Direct calculation yields  $x^2 - y^2 = a\sqrt{D}$ .

2 points.

Thus, we again obtain the equality

$$a = \lfloor a\sqrt{D} \rfloor.$$

The rest of the solution is the same as in the First Solution.

6 points.

**Third Solution.** We let  $a = x + y$  (note it must be a positive integer) and then the equality from the statement implies that  $a \leq x^2 - y^2 < a + 1$  which upon division by  $a$  implies

$$1 \leq x - y < 1 + \frac{1}{a}.$$

1 point.

Adding  $a = x + y$  to both inequalities implies

$$a + 1 \leq 2x < a + 1 + \frac{1}{a} \implies \frac{a+1}{2} \leq x < \frac{a+1}{2} + \frac{1}{2a}.$$

2 points.

Now, write  $x = \frac{a+1}{2} + \varepsilon$  for some  $\varepsilon$ . We see that  $y = \frac{a-1}{2} - \varepsilon$  and also that  $0 \leq \varepsilon < \frac{1}{2a} \leq \frac{1}{2}$ . We can compute

$$xy = \frac{a^2 - 1}{4} - (\varepsilon^2 + \varepsilon) \in \mathbb{N}$$

and note that  $0 \leq \varepsilon^2 + \varepsilon < \frac{3}{4}$ .

2 points.

If  $a$  is even,  $a^2 - 1$  gives remainder 3 upon division by 4 so the fractional part of  $\frac{a^2-1}{4}$  is  $\frac{3}{4}$  and due to  $\varepsilon^2 + \varepsilon < \frac{3}{4}$  we have that  $xy$  is not an integer.

2 points.

If  $a$  is odd,  $a^2 - 1$  is divisible by 4 so we must have  $\varepsilon^2 + \varepsilon = 0$  and  $\varepsilon = 0$  and we obtain the solutions

$$(x, y) = \left( \frac{a+1}{2}, \frac{a-1}{2} \right) = (n+1, n)$$

for any odd integer  $a$ , that is, any positive integer  $n$ .

3 points.

**Fourth Solution.** Again, denote  $a = x + y$  and  $D = (x - y)^2$  (both are integers as in the First Solution or Second Solution). Thus we again have

$$a = \lfloor a\sqrt{D} \rfloor.$$

4 points.

As in the Third Solution, we have that  $a = \lfloor a\sqrt{D} \rfloor$  implies that

$$1 \leq x - y = \sqrt{D} < 1 + \frac{1}{a}$$

.

1 point.

Applying the inequality of arithmetic and geometric means gives

$$a = x + y \geq 2\sqrt{xy} \geq 2$$

but as  $x \neq y$  equality can not hold. This gives that  $a \geq 3$  so  $\sqrt{D} \leq \frac{4}{3}$  and as  $D$  is an integer,  $D = 1$ .

2 points.

The rest of the solution is the same as in the First Solution.

3 points.

#### Notes on marking:

- In all four solutions, in the final part (last **3 points**), minor flaws should result in a **1 point** deduction.
- If a contestant has not made the steps prior to the final part of the solution, they can score at most **2 points** for the last part.
- Stating that all pairs of the form  $(n+1, n)$  are a solution is worth at most **1 point** out of the last **3 points**.
- Points from different solutions are not additive.

**Problem 3.** Let  $ABC$  be an acute-angled triangle with  $|BC| < |AC|$ . Let  $I$  be the incenter and  $\tau$  the incircle of  $ABC$ , which touches  $BC$  and  $AC$  at points  $D$  and  $E$ , respectively. The point  $M$  is on  $\tau$  such that  $BM$  is parallel to  $DE$  and  $M$  and  $B$  are on the same side of the angle bisector of  $\angle BCA$ . Let  $F$  and  $H$  be the intersections of  $\tau$  with  $BM$  and  $CM$  different from  $M$ , respectively. Let  $J$  be a point on the line  $AC$  such that  $JM$  is parallel to  $EH$ . Let  $K$  be the intersection of  $JF$  and  $\tau$  different from  $F$ .

Prove that the lines  $ME$  and  $KH$  are parallel.

(Steve Vo Dinh)

**First Solution.** Let  $T$  be the intersection of  $CF$  and  $\tau$  different from  $F$ . Consider the homothety centered at  $C$  that sends  $H$  to  $M$ .

It also sends  $T$  to  $F$  because of symmetry around the bisector of angle  $\angle ACB$ .

1 point.

Furthermore, it sends  $E$  to  $J$  because  $JM$  is parallel to  $EH$ .

1 point.

Since  $CE$  is tangent to  $\tau$ ,  $CJ$  is tangent to the circumcircle of  $\triangle MFJ$  using the aforementioned homothety.

4 points.

By the tangent chord lemma we have  $\angle CJM = \pi - \angle MFJ$ .

1 point.

Now notice that  $\angle EMH = \angle CEH = \angle CJM = \pi - \angle MFJ = \angle KFM = \angle MHK$ .

Thus,  $ME$  and  $KH$  are parallel, as desired.

3 points.

**Second Solution.** Let  $t$  denote the angle  $\angle JCF$ , and let  $z$  denote the angle  $\angle EFC$ .

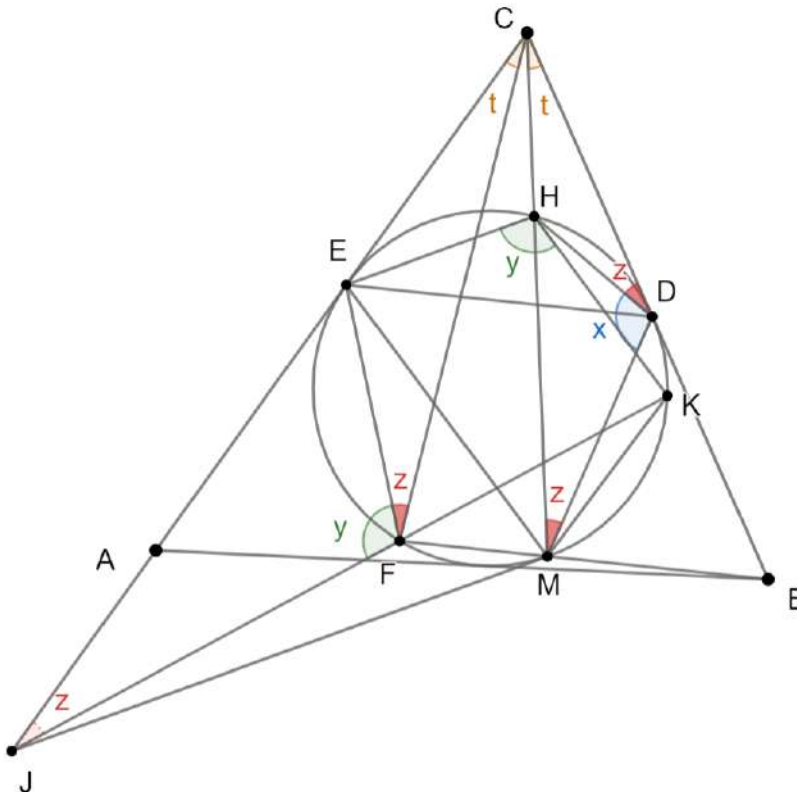

We claim that  $\triangle CJF \sim \triangle CDH$ .

We first note that  $\angle JCF = \angle DCM = t$ ,  $CD = CE$  and  $CM = CF$  using the symmetry around the bisector of angle  $\angle ACB$ . Namely, let  $\ell$  be the mentioned bisector. Then since  $FM$  and  $ED$  are parallel, we conclude that  $EDFM$  is an isosceles trapezoid, so  $D$  and  $E$  are symmetric around  $\ell$ , and the same holds for  $F$  and  $M$ .

**1 point.**

Using the fact that  $JM \parallel EH$ , the triangles  $JMC$  and  $EHC$  are similar, and we get  $\frac{CJ}{CM} = \frac{CE}{CH}$ , or equivalently  $\frac{CJ}{CF} = \frac{CD}{CH}$

**1 point.**

. We are now done by the side-angle-side theorem.

**4 points.**

Now, notice that from the tangent chord lemma applied to  $BC$  and  $HD$ , we have  $\angle HDC = \angle HMD$ . From this, it follows  $\angle EFC = \angle CMD = \angle HMD$  because of symmetry around angle  $\angle ACB$ .

Since we also have  $\angle HDC = \angle CJF$  from the aforementioned similarity, we obtain  $\angle HDC = \angle CJF = \angle EFC = z$ .

**1 point.**

From triangle  $JFC$ , we have  $\angle KHE = \angle JFE = \pi - \angle CJF - \angle JCF - \angle EFC = \pi - 2z - t$ .

From triangle  $CDM$  we have  $\angle MDH = \pi - \angle DMH - \angle DCH - \angle HDC = \pi - 2z - t$ . Thus,  $\angle MDH = \angle EHD$ , which implies that  $ED = HM$  as the angles across those chords are the same. Thus,  $EMKH$  is an isosceles trapezoid, so  $ME$  and  $KH$  are parallel, as desired.

**3 points.**

### Notes on marking:

- In both solutions, contestants that have done the angle-chase (final part of the solution), but haven't done the previous steps (up to minor flaws), are awarded **1 point** out of **3 points** for the final part, since it can be helpful, but it isn't very useful without the previous steps.
- Points from different solutions are not additive.

**Problem 4.** Let  $X = \{1, 2, 3, \dots, 300\}$ . A collection  $F$  of distinct (not necessarily non-empty) subsets of  $X$  is *lovely* if for any three (not necessarily distinct) sets  $A, B, C$  in  $F$ , at most three out of the following eight sets are non-empty:

$$\begin{array}{cccc} A \cap B \cap C, & \bar{A} \cap B \cap C, & A \cap \bar{B} \cap C, & A \cap B \cap \bar{C}, \\ \bar{A} \cap \bar{B} \cap C, & \bar{A} \cap B \cap \bar{C}, & A \cap \bar{B} \cap \bar{C}, & \bar{A} \cap \bar{B} \cap \bar{C}, \end{array}$$

where  $\bar{S}$  denotes the set of all elements of  $X$  that are not in  $S$ .

What is the greatest possible number of sets in a lovely collection?

(Miroslav Marinov)

**First Solution.** We claim that  $|F| \leq 8$ .

If we apply the condition to the triple  $(A, B, B)$  for some distinct sets  $A, B \in F$  we obtain that at most three of the sets  $A \cap B, B \setminus A, A \setminus B, X \setminus (A \cup B)$  are nonempty. Therefore, for each pair of distinct sets  $A, B \in F$  we either have that  $A \subset B$  or  $B \subset A$  or  $A, B$  disjoint or  $A \cup B = X$ .

**1 point.**

Now fix an  $F$  of maximal size and assume  $|F| \geq 9$ . Consider  $G = F \setminus \{\emptyset, X\}$  which has  $|G| \geq 7$ . We wish to show there exist  $A, B \in G$  with  $A \cup B = X$  and nonempty intersection. Assume the opposite, that all  $A, B$  in  $G$  are either disjoint or contained in each other.

First, assume a pair of sets with  $A \supset B$  exists in  $G$ .

If there exists  $C \in G$  such that  $A \supset B \supset C$  we obtain that

$$\begin{array}{l} C = A \cap B \cap C \\ B \setminus C = A \cap B \cap \bar{C} \\ A \setminus B = A \cap \bar{B} \cap \bar{C} \\ X \setminus A = \bar{A} \cap \bar{B} \cap \bar{C} \end{array}$$

are all nonempty, a contradiction. Similarly,  $A$  has no superset in  $G$ .

**1 point.**

If there exist distinct  $C, D \in G$  such that  $A \supset B, C, D$ , the previous consideration forces  $B, C, D$  to be disjoint and we obtain that

$$\begin{array}{l} C = A \cap \bar{B} \cap C \\ B = A \cap B \cap \bar{C} \\ X \setminus A = \bar{A} \cap \bar{B} \cap \bar{C} \\ A \setminus (B \cup C) = A \cap \bar{B} \cap \bar{C} \end{array}$$

and as the first three sets are clearly nonempty, the last one must be empty and we have  $B \cup C = A$ . However, we now similarly get  $D \cup B = D \cup C = A$  and  $D$  disjoint from  $B, C$  so  $B = C$ , a contradiction, so  $A$  has at most two subsets in  $G$ .

**1 point.**

Now, due to  $|G| \geq 7$  we can choose distinct  $C, D \in G$  with  $C, D$  both disjoint from  $A$ . We now have the sets

$$\begin{array}{l} C = \bar{A} \cap \bar{B} \cap C \\ B = A \cap B \cap \bar{C} \\ A \setminus B = A \cap \bar{B} \cap \bar{C} \\ X \setminus (A \cup C) = \bar{A} \cap \bar{B} \cap \bar{C} \end{array}$$

and as the first three sets are clearly nonempty, the last one must be empty so  $C = \bar{A}$ . However, now we have a similar consideration for  $D$  so  $C = D = \bar{A}$ , a contradiction. Therefore, any pair of sets  $A, B \in F$  are disjoint.

**2 points.**

Now, take some  $A, B, C, D \in F$  and note that

$$\begin{aligned} A &= A \cap \overline{B} \cap \overline{C} \\ B &= \overline{A} \cap B \cap \overline{C} \\ C &= \overline{A} \cap \overline{B} \cap C \\ X \setminus (A \cup B \cup C) &= \overline{A} \cap \overline{B} \cap \overline{C} \end{aligned}$$

so as the first three are clearly nonempty, the last one must be empty so we have  $A \cup B \cup C = X$  and specially  $C = \overline{A \cup B}$ . However, the same consideration now applies to  $D$  so we obtain  $D = C$ , a contradiction.

**1 point.**

Finally, take a pair  $A, B \in G$  such that  $A \cup B = X$  and  $A \cap B \neq \emptyset$ . Consider some other  $C \in G$ . As all three sets  $A \cap B$ ,  $A \cap \overline{B}$ ,  $\overline{A} \cap B$  are nonempty, each has to have a nonempty intersection either with  $C$  or with  $\overline{C}$ . As we can have at most three such nonempty intersections, we have that all of them are either a subset of  $C$  or a subset of  $\overline{C}$ . As those three sets partition  $X$ , this gives us at most  $2^3 = 8$  possible choices for  $C$  and as  $C \in G = F \setminus \{\emptyset, X\}$  and  $C \neq A, C \neq B$ , we cannot have that they're all contained in  $C$  or in  $\overline{C}$  and we cannot have  $C = A$  or  $C = B$  so there are at most 4 possibilities for  $C$  and we obtain  $|G| \leq 6$ , a contradiction.

**3 points.**

Finally, we have that  $|G| \leq 6$  so  $|F| \leq 8$  as desired.

One example of this is  $F$  containing  $\emptyset, \{1, 2, \dots, 100\}, \{101, 102, \dots, 200\}, \{201, 300\}$  and their complements. It's easy to check that this is a lovely family.

**1 point.**

**Second Solution.** Let  $F$  be a lovely family with the maximum possible number of sets. We claim that  $F$  contains less than 9 sets. Suppose for the sake of contradiction that it contains more than 8 sets.

Note that the problem's condition is symmetric under taking complements. In other words, the sets  $A, B, C$  satisfy the problem's condition if and only if the sets  $\overline{A}, B, C$  satisfy it. Because of this, we may assume that for any  $A \in F$  we also have  $\overline{A} \in F$ . Since  $F$  consists of at least 9 sets, it follows that  $F$  contains at least 5 sets which all contain the number 1.

**1 point.**

We'll prove this is impossible.

We rephrase the problem. Represent each set  $A \in F$  with a  $300 \times 1$  column consisting of zeroes and ones, so that the  $k$ th number in the column is 0 if  $k \notin A$  and 1 if  $k \in A$ .

Let  $A, B, C, D, E$  be five sets from  $F$  which all contain 1. Consider a  $300 \times 5$  table consisting of 5 columns corresponding to  $A, B, C, D, E$  respectively.

Now note that the problem's condition rephrases as follows: for any choice of three columns from the table, the  $300 \times 3$  table consisting of those three columns contains at most 3 different rows out of possible 8.

**1 point.**

**Lemma.** Suppose that there is a row  $r$  in the mentioned  $300 \times 5$  table which doesn't contain all ones and contains at least two ones. Then for any two columns which contain a one in the row  $r$ , one of them contains all ones.

*Proof.* Without loss of generality we may assume that the row  $r$  is of the form  $110xy$ , where  $x, y \in \{0, 1\}$ . Since the first two columns can't be the same, there must exist a row whose first two entries are distinct. Without loss of generality, this row is of the form  $10uvw$  where  $u, v, w \in \{0, 1\}$ . Now look at the first three columns in the table. They contain rows  $111, 10u, 110$ . Those are three distinct rows, so the first three entries of any row in the table are  $111, 10u$  or  $110$ . This implies that every row must start with a one, which means that the first column contains all ones.

□

**3 points.**

From this lemma, it immediately follows that there is no row which contains more than 2 and less than 5 ones, and if there is a row which contains exactly 2 ones, then there is a column which contains all ones.

In any case, take a look at the four columns which do not contain all ones. Each of the rows in the corresponding  $300 \times 4$  table either contains no ones, a single one, or four ones.

Since the columns need to be distinct, there must exist at least three out of four of the following rows:

1000  
0100  
0010  
0001

**2 points.**

Without loss of generality we can assume that the table contains the first three among them. The table also contains the first row with all ones. However, looking at the first three columns then yields a contradiction, since there exist the following four distinct rows:

111  
100  
010  
001

**2 points.**

The example which proves that a lovely family can contain 8 sets is the same as in the first solution.

**1 point.**

**Notes on marking:**

- In the First Solution, solving the case when there exist  $A, B$  whose union is  $X$  and intersection is nonempty is worth **3 points**. It is possible to score **1 point** or **2 points** on this part of the problem if a contestant makes partial progress or has a minor flaw in their proof of this case.

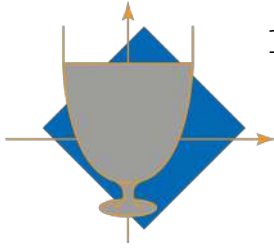

# 11<sup>TH</sup> EUROPEAN MATHEMATICAL CUP

10<sup>th</sup> December 2022 - 18<sup>th</sup> December 2022

Senior Category



**Problem 1.** Let  $n \geq 3$  be a positive integer. Alice and Bob are playing a game in which they take turns colouring the vertices of a regular  $n$ -gon. Alice plays the first move. Initially, no vertex is coloured. Both players start the game with 0 points.

On their turn, the player colours a vertex  $V$  which hasn't been coloured and gains  $k$  points, where  $k$  is the number of neighbouring vertices of  $V$  which have already been coloured. (Thus,  $k$  is either 0, 1 or 2.)

The game ends when all vertices have been coloured, and the player with more points wins. If the players have the same number of points, no one wins. Determine all  $n \geq 3$  for which Alice has a winning strategy, and all  $n \geq 3$  for which Bob has a winning strategy.

(*Josip Pupić*)

**Problem 2.** We say a positive integer  $n$  is *lovely* if there exist a positive integer  $k$  and (not necessarily distinct) positive integers  $d_1, d_2, \dots, d_k$  such that  $n = d_1 d_2 \dots d_k$  and

$$d_i^2 \mid n + d_i$$

for all  $i \in \{1, \dots, k\}$ .

- Are there infinitely many lovely numbers?
- Does there exist a lovely number greater than 1 which is a square of an integer?

(*Ivan Novak*)

**Problem 3.** Let  $\mathbb{R}$  denote the set of all real numbers. Find all functions  $f : \mathbb{R} \rightarrow \mathbb{R}$  such that

$$f(x^3) + f(y)^3 + f(z)^3 = 3xyz$$

for all  $x, y, z \in \mathbb{R}$  such that  $x + y + z = 0$ .

(*Kyprianos-Iason Prodromidis*)

**Problem 4.** Five points  $A, B, C, D$  and  $E$  lie on a circle  $\tau$  clockwise in that order such that  $AB$  is parallel to  $CE$  and  $\angle ABC > 90^\circ$ . Let  $k$  be a circle tangent to  $AD, CE$  and  $\tau$  such that the circles  $k$  and  $\tau$  touch on the arc  $\widehat{ED}$  which doesn't contain  $A, B$  and  $C$ . Let  $F \neq A$  be the intersection of  $\tau$  and the line tangent to  $k$  passing through  $A$  different from  $AD$ .

Prove that there exists a circle tangent to  $BD, BF, CE$  and  $\tau$ .

(*Steve Vo Dinh*)

*Time: 240 minutes.*

*Each problem is worth 10 points.*

*The use of calculators or any other instruments except rulers and compasses is not permitted.*

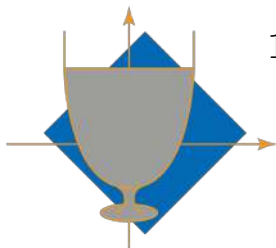

# 11<sup>TH</sup> EUROPEAN MATHEMATICAL CUP

10<sup>th</sup> December 2022 - 18<sup>th</sup> December 2022

Senior Category



## Problems and Solutions

**Problem 1.** Let  $n \geq 3$  be a positive integer. Alice and Bob are playing a game in which they take turns colouring the vertices of a regular  $n$ -gon. Alice plays the first move. Both players start the game with 0 points. In each turn, player picks a vertex  $V$  which hasn't been coloured and colours it. Then, they add  $k$  points to their point tally, where  $k$  is the number of neighbouring vertices of  $V$  which have already been coloured. (Thus,  $k$  is either 0, 1 or 2.)

The game ends when all vertices have been coloured, and the player with more points wins. For every  $n \geq 3$ , determine which player has a winning strategy.

*(Josip Pupić)*

**First Solution.** We'll prove that Alice wins when  $n$  is odd and Bob wins when  $n$  is even.

**Case 1:**  $n$  is even.

Bob's strategy is the following. He picks a line  $\ell$  passing through the midpoints of two opposite sides of the  $n$ -gon. This splits the  $n$ -gon into two halves.

Then, for any move Alice makes, Bob makes a move which mirrors Alice's move with respect to this line.

**3 points.**

If in some move Alice picks a vertex which isn't an endpoint of a side through which  $\ell$  passes, then Bob wins the same amount of points as her in his next move, because each half of the  $n$ -gon has the same vertices coloured before their moves.

If Alice picks a vertex which is an endpoint of a side through which  $\ell$  passes, then Bob wins one point more than Alice. That's because its neighbour on the same side of  $\ell$  is coloured if and only if the mirroring vertex is coloured, so they get the same amount of points for the vertices on the same side of  $\ell$ , but Bob gets one extra point since he picks a vertex adjacent to Alice's.

Since Bob has to pick such a vertex twice, Bob wins by two points difference in the end.

**2 points.**

**Case 2:**  $n$  is odd.

Alice's strategy is the following. She makes an arbitrary first move, and then considers a line  $\ell$  passing through the vertex she picked and the midpoint of the opposite side of the  $n$ -gon. She then uses the same strategy as Bob, mirroring his moves with respect to  $\ell$ .

**3 points.**

Similarly to the first solution, they get the same amount of points when Bob chooses a vertex which isn't an endpoint of the side through which  $\ell$  passes.

When Bob picks a vertex which is an endpoint of the side through which  $\ell$  passes, Alice wins one more point than Bob for the same reasons as in the first case.

Since Bob has to pick such a vertex, Alice wins by one point difference in the end.

**2 points.**

**Second Solution.** We'll prove that Bob wins for even  $n$  and Alice wins for odd  $n$ .

**Case 1:**  $n$  is even.

Consider vertices labeled from 1 to  $n$  in clockwise direction and consider vertices  $2a - 1$  and  $2a$  paired for each  $a \in \{1, 2, \dots, \frac{n}{2}\}$ .

Bob's strategy will be to colour a vertex belonging to the same pair as the vertex Alice coloured in her previous turn.

**3 points.**

After Bob's turn vertices in each pairing will either both be coloured or both uncoloured so Bob will always be able to colour the chosen vertex.

Since Alice always colours a vertex adjacent to an uncolored vertex, she gains at most 1 point per turn. Similarly Bob always colours a vertex adjacent to a colored vertex so he gains at least 1 point per turn.

They each play for  $\frac{n}{2}$  turns. However since Alice plays first, she gains 0 points for her first turn because there are no coloured vertices yet, and Bob plays last so he gains 2 points for his last turn because all vertices are coloured at the end. Bob wins by at least 2 points difference.

**2 points.**

**Case 2:**  $n$  is odd.

Label the vertices from 0 to  $n - 1$  in clockwise direction and consider vertices  $2a - 1$  and  $2a$  paired for each  $a \in \{1, 2, \dots, \frac{n-1}{2}\}$ .

Alice will firstly colour vertex labeled with 0, and all other turns (similarly to Bob's strategy) colour a vertex belonging to the same pair as the vertex Bob coloured in his previous turn.

**3 points.**

She will also always be able to colour the chosen vertex.

Alice now gains 0 points for her first turn, 2 points for her last turn and at least 1 point for all other turns, while Bob gains at most 1 point for all turns. Alice scores at least  $\frac{n+1}{2}$  points and Bob scores at most  $\frac{n-1}{2}$  points so Alice wins by at least 1 point.

**2 points.**

**Third Solution.** We'll prove by mathematical induction that Bob wins when  $n$  is even and Alice wins when  $n$  is odd.

For  $n = 3$ , Alice wins by 1 point no matter how they play.

For  $n = 4$ , Bob wins by 2 points by choosing a vertex adjacent to the one Alice chooses in the first move.

Suppose that for all  $k < n$ , where  $n \geq 5$ , Alice wins by 1 when  $k$  is odd and Bob wins by 2 when  $k$  is even.

We now prove the same holds for  $n$ . We again split into two cases.

**Case 1:**  $n$  is even.

Bob's first move is to pick a vertex adjacent to the one Alice picked. He wins one point by doing this. However, note that if we merge the chosen vertices, we have a same game on an  $(n - 1)$ -gon in which Bob has made the first move and is leading by 1. By inductive hypothesis applied to the  $(n - 1)$ -gon, Bob wins the game on the  $(n - 1)$ -gon by 1 point, so he then wins the game by 2 points.

**3 points.**

**Case 2:**  $n$  is odd.

Alice's first move is arbitrary.

If Bob plays his first move to a vertex adjacent to the one Alice chose, he scores 1 point, but we can again merge the two vertices together and get a game on an  $(n - 1)$ -gon in which Bob has made the first move, and by inductive hypothesis Alice wins this game on an  $(n - 1)$ -gon by 2 points, so she wins the game on the  $n$ -gon by 1 point.

If Bob plays the first move in a vertex such that there is exactly one vertex between the vertices he and Alice chose, then Alice can pick the vertex in between them. She scores 2 points in that move. Merging the three used vertices gives us a game on an  $n - 2$ -gon in which Alice has played the first move, and she wins that game by the inductive hypothesis, so she also wins the game on an  $n$ -gon.

**1 point.**

If Bob plays the first move to a vertex which is at distance at least two from the one Alice chose, he doesn't score any points. If we connect the two chosen vertices, we've split the  $n$ -gon into a  $(k + 1)$ -gon and an  $(n + 1 - k)$ -gon for some  $k \geq 3$ ,  $k < n - 2$ . Merging the two chosen vertices in each of the two polygons gives us a  $k$ -gon and an  $(n - k)$ -gon, where  $k \geq 3$  and  $n - k \geq 3$ . Note that exactly one among  $k$  and  $n - k$  is even. Furthermore, also note that the game is now split into two games, a game on a  $k$ -gon and a game on an  $n - k$ -gon, in which the first moves have been played.

**2 points.**

Note that exactly one among  $k$  or  $n - k$  is even. Without loss of generality let  $k$  be even. Then Alice can make her first move in a  $k$ -gon and every other move in the same polygon in which Bob played his move before her. Doing so optimally, using the induction hypotheses for  $k$  and  $n - k$ , Alice wins both the game on the  $k$ -gon and the game on the  $(n - k)$ -gon, since she is the first player on the  $(n - k)$ -gon and the second player on the  $k$ -gon.

**Notes on marking:**

- In the first two solutions, each case depending on the parity of  $n$  is worth **5 points** in total. Explaining the strategy is worth **3 points**, while proving that the strategy is winning is worth **2 points**. If a contestant provides a different winning strategy, the same marking scheme applies.
- If a contestant has a minor flaw in their proof that the strategy is winning, they should be deducted **1 point** out of **2 points** for that part of the solution.
- Proving that the total number of points in the game is  $n$  is worth **1 point** out of possible **5 points** for the case when  $n$  is odd. This is not additive with the rest of the points given for the odd case.
- Providing a non-losing strategy for the case when  $n$  is even is worth **1 point**. Proving that the strategy is non-losing should be awarded additional **1 point**. These points are not additive with the rest of the points given for the even case.

**Problem 2.** We say a positive integer  $n$  is *lovely* if there exist a positive integer  $k$  and (not necessarily distinct) positive integers  $d_1, d_2, \dots, d_k$  such that  $n = d_1 d_2 \dots d_k$  and

$$d_i^2 \mid n + d_i$$

for all  $i \in \{1, \dots, k\}$ .

- (a) Are there infinitely many lovely numbers?  
 (b) Does there exist a lovely number greater than 1 which is a square of an integer?

(Ivan Novak)

**Solution.** (a) The answer is YES. We prove this using induction. Note that 1 is lovely since  $1 = 1^2$  and  $1^2 \mid 1 + 1$ . Suppose that some number  $n$  is lovely and let  $d_1 d_2 \dots d_k$  be the divisors such that  $d_i^2 \mid n + d_i$ . We claim that  $n(n+1)$  is lovely as well, with the decomposition  $n(n+1) = d_1 d_2 \dots d_k (n+1)$ . First note that

$$(n+1)^2 \mid (n(n+1))^2 + n + 1 = (n+1)^2(n^2 + 1).$$

Furthermore, for any  $i \leq k$ ,  $d_i^2 \mid n^2$  and  $d_i^2 \mid n + d_i$ , so also

$$d_i^2 \mid n^2 + n + d_i.$$

Thus,  $n(n+1)$  is indeed lovely, and part (a) is solved.

**3 points.**

(b) The answer is NO. Suppose that some square number  $n > 1$  is lovely, with the decomposition  $d_1 d_2 \dots d_k$ . Without loss of generality we may assume that all  $d_i$  are greater than 1, since adding or removing number 1 from the decomposition doesn't affect the problem's conditions.

Note that the  $d_i$  are pairwise coprime, since if some prime number  $p$  divides  $d_i$  and  $d_j$ , then  $\nu_p(d_j) < \nu_p(n)$  so  $\nu_p(n+d_j) = \nu_p(d_j) < 2\nu_p(d_j)$ , which is impossible since  $d_j^2 \mid n + d_i$ . Consequently, since  $n$  is a square, all the  $d_i$  are squares.

**1 point.**

If we multiply the  $k$  conditions  $d_i^2 \mid n + d_i$  for  $i = 1, \dots, k$ , we get

$$d_1^2 d_2^2 \dots d_k^2 \mid (n + d_1)(n + d_2) \dots (n + d_k),$$

or equivalently

$$n^2 \mid (n + d_1)(n + d_2) \dots (n + d_k).$$

**1 point.**

If we expand the  $k$  brackets on the right hand side to get  $2^k$  summands, the only summands which are not divisible by  $n^2$  are  $d_1 d_2 \dots d_k = n$  and those of the form  $n \cdot d_1 \dots d_{i-1} \cdot d_{i+1} \dots d_k = \frac{n^2}{d_i}$  for some  $i \in \{1, \dots, k\}$ . Thus, the condition can be rewritten as

$$n^2 \mid n + \frac{n^2}{d_1} + \dots + \frac{n^2}{d_k}.$$

**2 points.**

This means that the number

$$\frac{1}{n} + \frac{1}{d_1} + \dots + \frac{1}{d_k}$$

is a positive integer. However, note that for every positive integer  $N$  we have

$$\begin{aligned} \frac{1}{2^2} + \frac{1}{3^2} + \dots + \frac{1}{N^2} &< \frac{1}{1 \cdot 2} + \frac{1}{2 \cdot 3} + \dots + \frac{1}{(N-1)N} \\ &= \frac{1}{1} - \frac{1}{2} + \frac{1}{2} - \frac{1}{3} + \dots + \frac{1}{N-1} - \frac{1}{N} \\ &= 1 - \frac{1}{N} < 1. \end{aligned}$$

This means that the sum  $\frac{1}{d_1} + \dots + \frac{1}{d_k} + \frac{1}{n}$  is less than 1 as well since it is a sum of reciprocals of distinct squares greater than 1. This means it cannot be a positive integer and we've reached a contradiction.

**3 points.**

**Notes on marking:**

- In part (a), it's possible to score partial points as follows. If a contestant tries constructing a lovely number  $d_1 \dots d_k d_{k+1}$  by starting from a lovely number  $d_1 d_2 \dots d_k$ , and writes down that  $d_{k+1}$  should be congruent to 1 modulo  $d_i$  for  $i \leq k$ , they should receive **1 point** for part (a). If they write down the condition  $d_{k+1} \mid d_1 d_2 \dots d_k + 1$  along with the condition  $d_{k+1} \equiv 1 \pmod{d_i}$ , they should receive **2 points** for part (a). Only writing down the condition  $d_{k+1} \mid d_1 d_2 \dots d_k + 1$  is worth **0 points** on its own.

- In the induction step in part (a), stating the claim "When  $n$  is lovely, then  $n(n+1)$  is lovely" without any proof should be awarded **1 point** out of possible **3 points** for part (a). Stating the claim and also providing the decomposition of  $n(n+1)$  into  $d_i$ , but not checking that they satisfy the conditions should be awarded **2 points** out of possible **3 points**. A check doesn't necessarily need to be explicit, but it has to be written down in some form.
- In the last step of the solution of part (b), stating the inequality  $\frac{1}{d_1} + \dots + \frac{1}{d_k} + \frac{1}{n} < 1$  should be awarded **1 point** out of possible **3 points** for that part. To prove the inequality, one may also (without proof, of course) use the well-known identity  $\sum_{n=1}^{\infty} \frac{1}{n^2} = \frac{\pi^2}{6}$ .

**Problem 3.** Let  $\mathbb{R}$  denote the set of all real numbers. Find all functions  $f : \mathbb{R} \rightarrow \mathbb{R}$  such that

$$f(x^3) + f(y)^3 + f(z)^3 = 3xyz$$

for all  $x, y, z \in \mathbb{R}$  such that  $x + y + z = 0$ .

(Kyprianos-Iason Prodromidis)

**First Solution.** First of all, for  $x = y = z = 0$ , we get that

$$f(0) + 2f(0)^3 = 0 \Leftrightarrow f(0)(2f(0)^2 + 1) = 0 \Leftrightarrow f(0) = 0.$$

Now, let  $x = 0$  and  $z = -y$ . This tells us that

$$f(y)^3 + f(-y)^3 = 0 \Leftrightarrow f(-y) = -f(y), \forall y \in \mathbb{R},$$

so  $f$  is odd.

**1 point.**

Moreover, for  $z = 0$  and  $y = -x$ , we have

$$f(x^3) + f(-x)^3 = 0 \Leftrightarrow f(x^3) = f(x)^3, \forall x \in \mathbb{R},$$

because  $f$  is odd.

**1 point.**

This means that the original equation becomes

$$f(x)^3 + f(y)^3 + f(z)^3 = 3xyz,$$

for all  $x, y, z$  such that  $x + y + z = 0$ , and by substituting  $z = -x - y$  we can transform this into the equation (using also the fact that  $f$  is odd),

$$f(x)^3 + f(y)^3 + f(-x - y)^3 = -3xy(x + y) \Leftrightarrow f(x + y)^3 = f(x)^3 + f(y)^3 + 3xy(x + y), \forall x, y \in \mathbb{R}. \quad (1)$$

**Lemma:** For all  $n \in \mathbb{N}$  and  $x \in \mathbb{R}$ , the following relation holds:

$$f(nx)^3 = nf(x)^3 + (n^3 - n)x^3.$$

*Proof.* We proceed by induction on  $n$ . For  $n = 1$  the statement is obvious for all  $x$ . Next, if this relation holds for some  $n \in \mathbb{N}$  and all  $x$ , then by putting  $y \rightarrow nx$  in (1), we conclude that

$$\begin{aligned} f((n+1)x)^3 &= f(x)^3 + f(nx)^3 + 3n(n+1)x^3 = (n+1)f(x)^3 + (n^3 - n + 3n(n+1))x^3 \\ &= (n+1)f(x)^3 + ((n+1)^3 - (n+1))x^3, \end{aligned}$$

and the Lemma follows. □

**1 point.**

Next, we fix  $x \in \mathbb{R}$  and we compute  $f(n^3x^3)^3 = f(nx^9)$  in two different ways for all  $n \in \mathbb{N}$ . Of course,

$$f(n^3x^3)^3 = n^3f(x^3)^3 + (n^9 - n^3)x^9 = n^9x^9 + n^3(f(x)^9 - x^9).$$

On the other hand, we have

$$\begin{aligned} f(nx)^9 &= (nf(x)^3 + (n^3 - n)x^3)^3 \\ &= n^3f(x)^9 + 3n^2(n^3 - n)f(x)^6x^3 + 3n(n^3 - n)^2f(x)^3x^6 + (n^3 - n)^3x^9 \\ &= n^9x^9 + 3n^7(f(x)^3x^6 - x^9) + 3n^5(f(x)^6x^3 - 2f(x)^3x^6 + x^9) \\ &\quad + n^3(f(x)^9 - 3f(x)^6x^3 + 3f(x)^3x^6 - x^9). \end{aligned}$$

**3 points.**

This means that the polynomials

$$\begin{aligned} p_x(y) &= x^9y^9 + (f(x)^3 - x^3)y^3 \quad \text{and} \\ q_x(y) &= x^9y^9 + 3x^6(f(x)^3 - x^3)y^7 + 3x^3(f(x)^3 - x^3)^2y^5 + (f(x)^3 - x^3)^3y^3 \end{aligned}$$

are equal for infinitely many values of  $y$ , thus they are equal as polynomials. Comparing the coefficients of  $y^7$ , we get that  $f(x)^3 = x^3 \Leftrightarrow f(x) = x, \forall x \in \mathbb{R}$ . This function obviously satisfies the condition of the problem.

**4 points.**

**Second Solution.** The facts that  $f(0) = 0$ ,  $f$  is odd and  $f(x^3) = f(x)^3$  are obtained in the same way as in the previous solution.

**2 points.**

The same way as in the previous solution, we obtain the following equality for all  $n \in \mathbb{N}$ ,  $x \in \mathbb{R}$ :

$$f(nx)^3 = nf(x)^3 + (n^3 - n)x^3.$$

**1 point.**

In particular, for  $n = 8$  and  $x^3 \neq 0$ , we have

$$f(8x^3)^3 = 8f(x^3)^3 + (8^3 - 8)x^9.$$

On the other hand, we have

$$f(8x^3)^3 = f(2x)^9 = (2f(x)^3 + (2^3 - 2)x^3)^3.$$

**2 points.**

Simplifying the equality  $(2f(x)^3 + (2^3 - 2)x^3)^3 = 8f(x^3)^3 + (8^3 - 8)x^9$ , we obtain:

$$8f(x)^9 + 72f(x)^6x^3 + 216f(x)^3x^6 + 216x^9 = 8f(x)^9 + 504x^9,$$

which, dividing by  $72x^3$ , can be simplified to

$$f(x)^6 + 3f(x)^3x^3 = 4x^6.$$

This can be factored as

$$(f(x)^3 - x^3)(f(x)^3 + 4x^3) = 0.$$

Thus, for each  $x$ , we have either  $f(x) = x$  or  $f(x) = -\sqrt[3]{4x}$ .

**2 points.**

Suppose that there exists some  $y_0 \neq 0$  such that  $f(y_0) = -\sqrt[3]{4y_0}$ . Then, using the Lemma, we have

$$f(2y_0)^3 = 2f(y_0)^3 + 6y_0^3 = -8y_0^3 + 6y_0^3 = -2y_0^3,$$

which is impossible since  $f(2y_0)^3 \in \{2y_0^3, -8y_0^3\}$ . Thus,  $f(x) = x$  for all  $x \in \mathbb{R}$ . This function obviously satisfies the problem's condition.

**3 points.**

**Third Solution.** The facts that  $f(0) = 0$ ,  $f$  is odd and  $f(x^3) = f(x)^3$  are obtained in the same way as in the previous solutions.

**2 points.**

By setting  $z = -(x + y)$ , the equation can be rephrased as

$$f(x^3) + f(y^3) = f(x + y)^3 - 3xy(x + y).$$

Let  $g(x) := f(x)^3 - x^3$ . Then

$$g(x + y) = g(x) + g(y).$$

Also, from  $f(x^3) = f(x)^3$ , we obtain

$$g(x^3) = f(x)^9 - x^9 = g(x)(x^6 + f(x)^6 + x^3f(x)^3),$$

which can be rewritten in terms of  $g$  as

$$g(x^3) = g(x)(g(x)^2 + 3x^3g(x) + 3x^6).$$

**1 point.**

Note that  $f(1)^3 = f(1)$ , so  $f(1) \in \{0, 1, -1\}$ , which means  $g(1) \in \{0, -1, -2\}$ .

We now prove  $g(1) = 0$ . Note that  $g(2) = 2g(1) \in \{0, -2, -4\}$ , and

$$4g(2) = g(8) = g(2)(g(2)^2 + 24g(2) + 192).$$

If  $g(2) = 0$ , then  $g(1) = 0$ . Otherwise,  $g(2)^2 + 24g(2) + 192 = 4$ . However, checking for values  $g(2) = -2$  and  $g(2) = -4$  gives no solution, a contradiction. Thus,  $g(2) = 0$  and  $g(1) = 0$ .

We'll use the following notation. For a function  $h : \mathbb{R} \rightarrow \mathbb{R}$ ,  $\Delta h(x)$  will denote  $h(x + 1) - h(x)$ .

Now we express  $g((x+1)^3)$  in two different ways. The first way is the following:

$$\begin{aligned} g((x+1)^3) &= g(x+1)(g(x+1)^2 + 3(x+1)^3g(x+1) + 3(x+1)^2) \\ &= g(x)(g(x)^2 + 3(x+1)^3g(x) + 3(x+1)^6), \end{aligned}$$

where we used  $g(x+1) = g(x) + g(1) = g(x)$ .

The second way is the following:

$$\begin{aligned} g((x+1)^3) &= g(x^3) + 3g(x^2) + 3g(x) \\ &= g(x)(g(x)^2 + 3x^3g(x) + 3x^6) + 3g(x^2) + 3g(x). \end{aligned}$$

Thus, we have the equality

$$g(x)(g(x)^2 + 3(x+1)^3g(x) + 3(x+1)^2) = g(x)(g(x)^2 + 3x^3g(x) + 3x^6) + 3g(x^2) + 3g(x).$$

This gives us the following expression for  $g(x^2)$  via  $g(x)$ :

$$g(x^2) = g(x)(g(x)\Delta x^3 + \Delta x^6 - 1).$$

**2 points.**

Now we write  $g((x+1)^2)$  in two different ways.

The first way is

$$g((x+1)^2) = g(x)(g(x)\Delta(x+1)^3 + \Delta(x+1)^6 - 1).$$

The second way is

$$\begin{aligned} g((x+1)^2) &= g(x^2) + 2g(x) \\ &= g(x)(g(x)\Delta x^3 + \Delta x^6 + 1). \end{aligned}$$

**1 point.**

We claim that  $g(x) = 0$  for all  $x$ . If this isn't the case for some  $x$ , then

$$g(x)\Delta x^3 + \Delta x^6 + 1 = g(x)\Delta(x+1)^3 + \Delta(x+1)^6 - 1.$$

However, then the same holds for  $x+n$  for every positive integer  $n$  since  $g(x+n) = g(x) \neq 0$ . We conclude that the polynomial

$$p(y) := g(x)\Delta y^3 + \Delta y^6 + 1 - (g(x)\Delta(y+1)^3 + \Delta(y+1)^6 - 1)$$

has infinitely many zeroes. But its degree is 4, which gives us a contradiction. Thus,  $g(x) = 0$  for all  $x$ , so  $f(x)^3 = x^3$ , which means  $f(x) = x$ . It's easy to check that this function satisfies the problem's condition.

**4 points.**

#### Notes on marking:

- Points from different solutions are not additive.
- If a contestant doesn't comment that the function  $f(x) = x$  is indeed a solution, they can score at most **9 points** on the problem.
- Obtaining  $f(1) = 1$  (or equivalently  $g(1) = 0$ ) is worth **1 point**. However, this point is only additive with the first two points, and not additive with the remaining eight points.

**Problem 4.** Five points  $A, B, C, D$  and  $E$  lie on a circle  $\tau$  clockwise in that order such that  $AB$  is parallel to  $CE$  and  $\angle ABC > 90^\circ$ . Let  $k$  be a circle tangent to  $AD, CE$  and  $\tau$  such that the circles  $k$  and  $\tau$  touch on the arc  $ED$  which doesn't contain  $A, B$  and  $C$ . Let  $F \neq A$  be the intersection of  $\tau$  and the line tangent to  $k$  passing through  $A$  different from  $AD$ .

Prove that there exists a circle tangent to  $BD, BF, CE$  and  $\tau$ .

(Steve Vo Dinh)

**First Solution.** Let us present the main lemma first and we'll see later how the problem statement follows from this lemma.

**Lemma** Let  $ABCD$  be a cyclic quadrilateral and  $\gamma_1$  and  $\gamma_2$  be  $C$ -mixtilinear and  $D$ -mixtilinear incircles of triangles  $ABD$  and  $ABC$  respectively. The external common tangent  $t$  of circles  $\gamma_1$  and  $\gamma_2$  which is closer to  $CD$  is parallel to  $CD$ .

We will divide the proof into a few main claims.

*Claim 1* Let  $ABCD$  be a cyclic quadrilateral and  $\omega_1$  and  $\omega_2$  be incircles of triangles  $ABD$  and  $ABC$  respectively. The external common tangent  $\ell$  of circles  $\omega_1$  and  $\omega_2$  different from  $AB$  is parallel to  $CD$ .

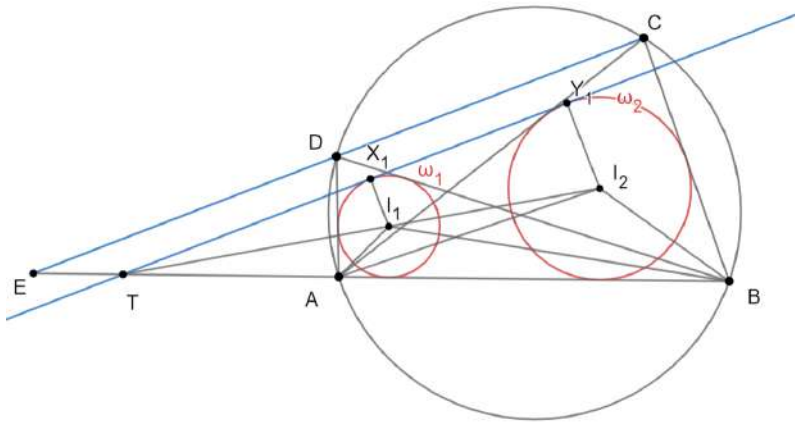

*Proof:* Let  $I_1, I_2$  be centers of  $\omega_1, \omega_2$  and let  $\ell$  touch  $\omega_1, \omega_2$  at  $X_1, Y_1$  respectively. Also let  $CD$  intersect  $AB$  at  $E$ .

We know that  $\angle AI_1B = 90^\circ + \frac{\angle ADB}{2} = 90^\circ + \frac{\angle ACB}{2} = \angle AI_2B$  so  $AI_1I_2B$  is cyclic quadrilateral. We know that lines  $AB, X_1Y_1, I_1I_2$  concur at the point  $T$  which is the center of homothety between  $\omega_1$  and  $\omega_2$ . It can be easily seen that line  $T - I_1 - I_2$  is the bisector of  $\angle X_1TA$  so we have that:

$$\angle X_1TA = 2 \cdot \angle I_1TA = 2 \cdot (\angle I_1AB - \angle TI_1A) = 2 \cdot (\angle I_1AB - \angle BI_2A) = 2 \cdot \left( \frac{\angle DAB}{2} - \frac{\angle ABC}{2} \right) = \angle DAB - \angle ABC$$

On the other hand  $\angle DAB - \angle ABC = \angle DAB - \angle ADE = \angle AED$ . In the end, we have that  $\angle X_1TA = \angle AED$  which implies that  $\ell \parallel CD$ .

**2 points.**

**Claim 2:** Consider homothety  $\mathcal{H}_1$  with center at  $D$  which sends  $\omega_1$  to  $\gamma_1$  and homothety  $\mathcal{H}_2$  with center at  $C$  which sends  $\omega_2$  to  $\gamma_2$ .  $\mathcal{H}_1$  and  $\mathcal{H}_2$  have the same ratio.

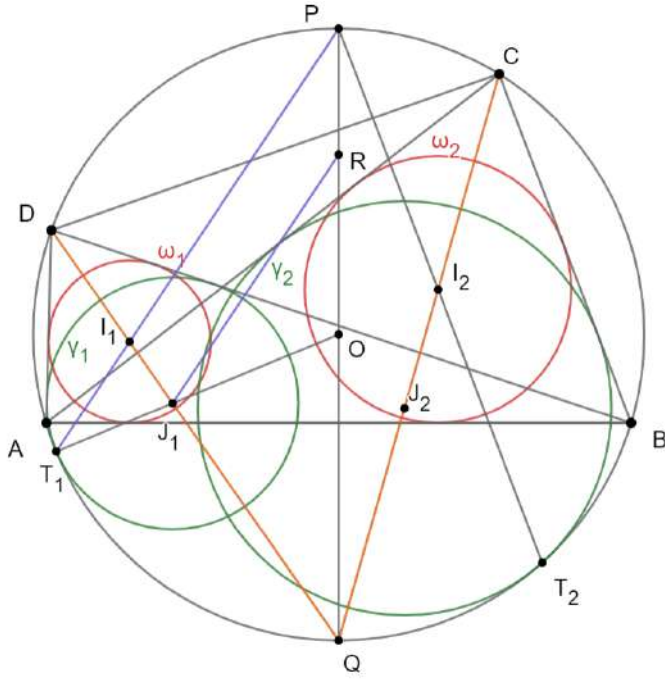

*Proof:* Let  $J_1, J_2$  be centers of  $\gamma_1, \gamma_2$  and let  $\gamma_1, \gamma_2$  touch  $\odot(ABCD)$  at  $T_1, T_2$  respectively. We know that  $J_1$  lies on the bisector of  $\angle ADB$  and that  $J_2$  lies on the bisector of  $\angle ACB$  so lines  $D - I_1 - J_1$  and  $C - I_1 - J_1$  intersect at  $Q$ , midpoint of an arc  $AB$  of  $\odot(ABCD)$  which doesn't contain  $C$  and  $D$ . We know that  $Q$  is the center of  $\odot(AI_1I_2B)$ . On the other hand it's the well-known property of the mixtilinear incircle that  $T_1I_1$  passes through  $P$ , midpoint an arc  $AB$  of  $\odot(ABCD)$  which contains  $C$  and  $D$ . Same holds for  $T_2I_2$ . Let  $O$  be the center of  $\odot(ABCD)$ . We know that  $O, J_1, T_1$  are collinear and that  $O$  is the midpoint of  $PQ$ . Let line passing through  $J_1$  parallel to  $PT_1$  intersect  $PQ$  at  $R$ . Then  $T_1J_1RP$  is an isosceles trapezoid so  $T_1J_1 = PR$ . On the other hand from  $RJ_1 \parallel PI_1$  we have that  $\frac{I_1J_1}{J_1T_1} = \frac{I_1J_1}{PR} = \frac{QI_1}{QP}$ . Analogously we can prove that  $\frac{I_2J_2}{J_2T_2} = \frac{QI_2}{QP}$ . Because of  $QI_1 = QI_2$  we can conclude that  $\frac{I_1J_1}{J_1T_1} = \frac{I_2J_2}{J_2T_2} = k$ .

Let  $r_1, r_2, \rho_1, \rho_2$  be radius of circles  $\omega_1, \omega_2, \gamma_1, \gamma_2$  respectively. We know that the ratio of  $\mathcal{H}_1$  is  $\frac{r_1}{\rho_1}$  and the ratio of  $\mathcal{H}_2$  is  $\frac{r_2}{\rho_2}$ . Also we have  $DI_1 = \frac{r_1}{\sin \frac{\angle ADB}{2}}, DJ_1 = \frac{\rho_1}{\sin \frac{\angle ADB}{2}}$ . We know that:

$$k = \frac{I_1J_1}{J_1T_1} = \frac{DJ_1 - DI_1}{\rho_1} = \frac{\frac{\rho_1 - r_1}{\sin \frac{\angle ADB}{2}}}{\rho_1}$$

which simplifies to  $\frac{r_1}{\rho_1} = 1 - k \cdot \sin \frac{\angle ADB}{2}$ .

Analogously we can get that  $\frac{r_2}{\rho_2} = 1 - k \cdot \sin \frac{\angle ACB}{2}$  so  $\frac{r_1}{\rho_1} = \frac{r_2}{\rho_2}$  because of  $\angle ADB = \angle ACB$ .

**3 points.**

**Claim 3:**  $t \parallel \ell$

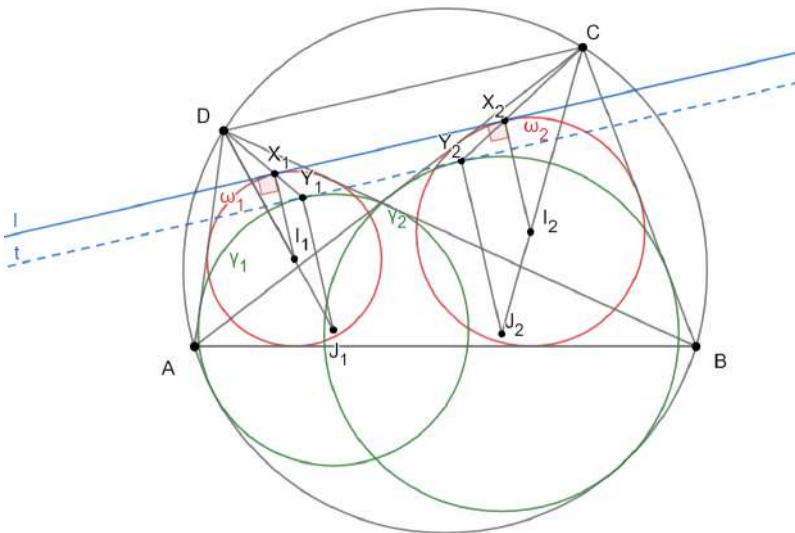

**Proof:** Let  $\ell$  touch  $\omega_1, \omega_2$  at  $X_1, X_2$  respectively. Let  $Y_1, Y_2$  be points at  $DX_1, CX_2$  respectively such that  $I_1X_1 \parallel J_1Y_1$  and  $I_2X_2 \parallel J_2Y_2$ . From  $\frac{DI_1}{DJ_1} = \frac{r_1}{\rho_1}$  and  $I_1X_1 \parallel J_1Y_1$  we have that  $J_1Y_1 = \rho_1$  so  $Y_1 \in \gamma_1$ . Analogously  $Y_2 \in \gamma_2$ . We know that  $\frac{DX_1}{DY_1} = \frac{r_1}{\rho_1} = \frac{r_2}{\rho_2} = \frac{DX_2}{DY_2}$ . This means that because of  $CD \parallel X_1X_2 \parallel Y_1Y_2$ . Now from  $I_1X_1 \parallel J_1Y_1$  we have that  $I_1X_1 \perp Y_1Y_2$  so  $Y_1Y_2$  is tangent to  $\gamma_1$ . Analogously  $Y_1Y_2$  is tangent to  $\gamma_2$  so we conclude that line  $Y_1Y_2$  coincides with  $t$ .

4 points.

Now let's conclude why the original problem follows from our main lemma.

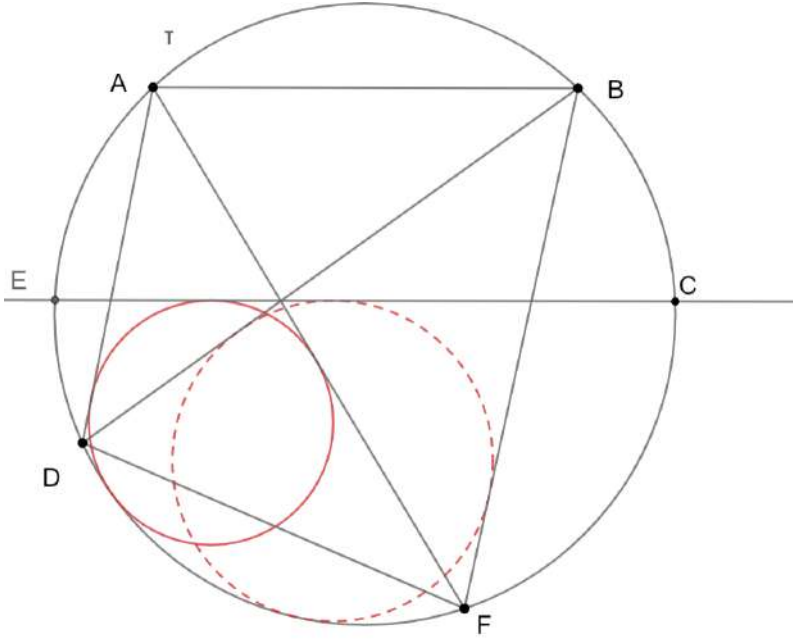

We know that  $CE$  is the tangent to the mixtilinear incircle of the triangle  $ADF$  which is parallel to  $AB$ . From our main lemma, we can conclude that  $CE$  has to be the tangent to the mixtilinear incircle of the triangle  $BDF$  as well because there exists a unique tangent line to mixtilinear incircle of the triangle  $ADF$  which is parallel to  $AB$  and closer to  $AB$  than the center of that circle.

1 point.

**Second Solution.**

Denote by  $X, Y, Q$  respectively the points where  $k$  touches  $CE, AF, \tau$ .

Furthermore, let  $Z$  be the point where  $k$  touches  $AD$ , and  $X_1$  the intersection of  $\tau$  and  $AX$ .

Let  $r$  be the circle tangent to  $BF, BD$  and  $CE$  at points  $Z_1, Y_1$  and  $Q_1$ . We claim that  $X_1$  is the touching point of  $r$  and  $\tau$ .

Define:

$$L := BF \cap CE, M := BD \cap CE$$

$$F_1 := AF \cap CE, D_1 := AD \cap CE$$

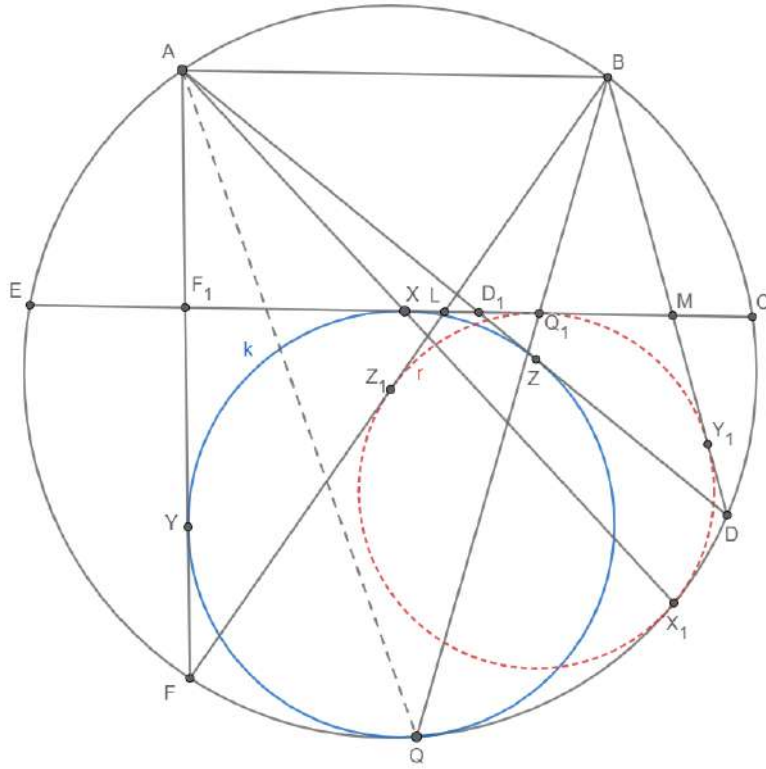

**Claim 1:**  $\triangle BDF \sim \triangle AF_1D_1$  and  $\triangle AFD \sim \triangle BML$

*Proof:* We have  $\angle D_1AF_1 = \angle FAD = \angle FBD$  and  $\angle AD_1F_1 = \angle D_1AB = \angle BAD = \angle BFD$ , so the triangles  $\triangle BDF$  and  $\triangle AF_1D_1$  have the same angles, which proves the first part of the claim.

The second part of the claim follows by the same logic.

**1 point.**

**Claim 2:**  $Q, Q_1$  and  $B$  are collinear

*Proof:* Due to the mixtilinear incircle lemma and **Claim 1** applied to  $\triangle AFD$  and  $\tau$ , we know that  $\angle LBQ_1 = \angle FAQ$ , from which the claim follows.

**1 point.**

Consider the inversion  $I$  with center  $B$  and radius  $R := \sqrt{BD \cdot BF}$ ,  $I(X) = X^*$ .

**1 point.**

From the properties of inversion we know that  $\triangle BFD \sim \triangle BD^*F^*$ , so by **Claim 1** we have  $\triangle AD_1F_1 \sim \triangle BD^*F^*$ .

Let  $H$  be the homothety that sends  $\triangle BD^*F^*$  to the  $\triangle AD_1F_1$ .

Let  $f = H \circ I$ . This function preserves angles, lines and circles after the inversion.

We can see that  $f(B) = A, f(D) = D_1, f(F) = F_1$ .

**1 point.**

The circle  $\tau$  goes through  $B, F$  and  $D$ , so because of inversion properties and because of the fact that  $F_1$  and  $D_1$  lie on  $CE$ , we conclude that  $f(\tau) = CE$ .

**1 point.**

$f(L)$  is a point on the line  $AF$ , because of the inversion and homothety properties for distance we know that

$$BL \cdot BL^* = BD \cdot BF$$

$$BL^* = \frac{BD \cdot BF}{BL}$$

We multiply this this by the homothety coefficient  $\frac{AD_1}{BD^*} = \frac{AD_1}{BF}$  and we get

$$BL^* = \frac{BD \cdot BF}{BL} \cdot \frac{AD_1}{BF}$$

$$BL^* = \frac{BD \cdot AD_1}{BL}$$

$$BL^* = \frac{BD \cdot AD_1}{BL}.$$

Because of **Claim 1** we have  $\frac{BL}{BM} = \frac{AD}{AF}$ , so we have

$$BL^* = \frac{BD \cdot AD_1 \cdot AF}{BM \cdot AD}$$

Because  $AB \parallel CE \parallel D_1M$ , we have  $\frac{AD_1}{BM} = \frac{AD}{BD}$

We conclude that  $BL^* = AF$ . Applying the same logic again, we conclude  $BM^* = AD$ .

Because of this, we know  $f(L) = F$  and  $f(M) = D$ . This implies that  $f(CE) = \tau$ .

**2 points.**

Because of **Claim 2**, we have  $\angle MBQ_1 = \angle DBQ = \angle DAQ$ , and so by the properties of  $f$  we have  $f(Q_1) = Q$  because  $f(Q_1)$  is on  $\tau$  and  $AQ$ .

**1 point.**

The function  $f$  preserves tangency because  $H$  and  $I$  also do, so  $r$  is sent to a circle tangent to  $\tau$  at  $Q$ , which is also tangent to  $AF$  and  $AD$  so  $f(r) = k$ ,  $f(Z_1) = Z$  and  $f(Y_1) = Y$ .

The point  $X_1$  is on  $\tau$ , but we also have  $\angle X_1BD = \angle X_1AD$ , so we know that  $f(X_1)$  is on the lines  $CE$  and  $AX_1$ , so we conclude  $f(X_1) = X$ .

Because  $f(\tau) = CE$  is tangent to  $f(r) = k$  at the point  $X$ , the touching point must be preserved, so  $X_1$  is the touching point of  $r$  and  $\tau$ , which proves the claim.

**2 points.**

**Notes on marking:**

- Points from different solutions are not additive.



# Statistics of the 11th European Mathematical Cup

10th Dec 2022 - 18th Dec 2022



## Junior Category

#	J1	J2	J3	J4	Graph J1	Graph J2	Graph J3	Graph J4
0	107	53	228	226				
1	21	79	6	12				
2	7	13	1	4				
3	4	3	3	1				
4	0	5	0	0				
5	2	10	2	0				
6	3	3	0	0				
7	8	7	0	0				
8	8	10	0	1				
9	9	7	0	1				
10	79	58	8	3				
$\Sigma$	248	248	248	248				
$\mu$	4.30	3.93	0.43	0.28				
$\sigma$	4.59	4.08	1.85	1.37				

## Senior Category

#	S1	S2	S3	S4	Graph S1	Graph S2	Graph S3	Graph S4
0	21	51	46	242				
1	1	23	17	5				
2	1	1	124	0				
3	5	41	39	0				
4	2	69	1	0				
5	3	1	1	0				
6	6	1	0	0				
7	2	13	1	0				
8	5	3	0	0				
9	14	1	1	2				
10	193	49	23	4				
$\Sigma$	253	253	253	253				
$\mu$	8.64	4.15	2.52	0.25				
$\sigma$	3.03	3.46	2.62	1.48				

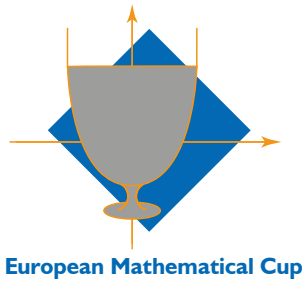

Enjoy solving complex problems using creative mathematical thinking? So do we!

Visit [www.janestreet.com](http://www.janestreet.com) to learn more about our educational programs, internships and full-time roles.

And of course - **Good Luck!**

Voliš rješavati teške probleme koristeći kreativno matematičko razmišljanje? I mi!

Posjeti [www.janestreet.com](http://www.janestreet.com) gdje možeš saznati više o edukacijama, stažiranjima i prilikama za zaposlenje.

I naravno - **Puno sreće!**

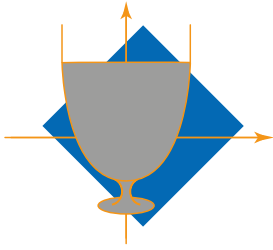

# 12<sup>TH</sup> EUROPEAN MATHEMATICAL CUP

9<sup>th</sup> December 2023 - 17<sup>th</sup> December 2023

Junior Category



**Problem 1.** Suppose  $a, b, c$  are positive integers such that

$$\gcd(a, b) + \gcd(a, c) + \gcd(b, c) = b + c + 2023.$$

Prove that  $\gcd(b, c) = 2023$ .

*Remark:* For positive integers  $x$  and  $y$ ,  $\gcd(x, y)$  denotes their greatest common divisor.

(Ivan Novak)

**Problem 2.** Let  $n \geq 5$  be an integer. There are  $n$  points in the plane, no three of them collinear. Each day, Tom erases one of the points, until there are three points left. On the  $i$ -th day, for  $1 \leq i \leq n - 3$ , before erasing that day's point, Tom writes down the positive integer  $v(i)$  such that the convex hull of the points at that moment has  $v(i)$  vertices. Finally, he writes down  $v(n - 2) = 3$ . Find the greatest possible value that the expression

$$|v(1) - v(2)| + |v(2) - v(3)| + \dots + |v(n - 3) - v(n - 2)|$$

can obtain among all possible initial configurations of  $n$  points and all possible Tom's moves.

*Remark.* A convex hull of a finite set of points in the plane is the smallest convex polygon containing all the points of the set (inside it or on the boundary).

(Ivan Novak, Namik Agić)

**Problem 3.** Consider an acute-angled triangle  $ABC$  with  $|AB| < |AC|$ . Let  $M$  and  $N$  be the midpoints of segments  $\overline{BC}$  and  $\overline{AB}$ , respectively. The circle with diameter  $\overline{AB}$  intersects the lines  $BC$ ,  $AM$  and  $AC$  at  $D$ ,  $E$ , and  $F$ , respectively. Let  $G$  be the midpoint of  $\overline{FC}$ . Prove that the lines  $NF$ ,  $DE$  and  $GM$  are concurrent.

(Michal Pecho)

**Problem 4.** We say a 2023-tuple of nonnegative integers  $(a_1, a_2, \dots, a_{2023})$  is *sweet* if the following conditions hold:

- $a_1 + a_2 + \dots + a_{2023} = 2023$ ,
- $\frac{a_1}{2^1} + \frac{a_2}{2^2} + \dots + \frac{a_{2023}}{2^{2023}} \leq 1$ .

Determine the greatest positive integer  $L$  such that

$$a_1 + 2a_2 + \dots + 2023a_{2023} \geq L$$

holds for every sweet 2023-tuple  $(a_1, a_2, \dots, a_{2023})$ .

(Ivan Novak)

Time: 240 minutes.

Each problem is worth 10 points.

The use of calculators or any other instruments except rulers and compasses is not permitted.

Cheating in any form is strictly prohibited. Sharing or posting the problems or solutions before the end of the competition (18th of December) to anyone who might participate is strictly prohibited.

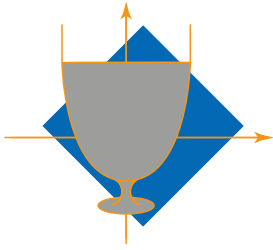

PROBLEMS AND SOLUTIONS OF THE  
12<sup>TH</sup> EUROPEAN MATHEMATICAL CUP  
9<sup>th</sup> December 2023 - 17<sup>th</sup> December 2023



Junior Category

**Problem 1.** Suppose  $a, b, c$  are positive integers such that

$$\gcd(a, b) + \gcd(a, c) + \gcd(b, c) = b + c + 2023.$$

Prove that  $\gcd(b, c) = 2023$ .

*Remark:* For positive integers  $x$  and  $y$ ,  $\gcd(x, y)$  denotes their greatest common divisor.

(Ivan Novak)

**Solution.** We want to prove  $\gcd(a, b) = b$  and  $\gcd(a, c) = c$ , since then the equality from the problem statement implies  $\gcd(b, c) = 2023$ .

1 point.

Note that  $\gcd(a, b)$  is a divisor of  $b$  and  $\gcd(b, c)$  is a divisor of  $c$ , so we must have  $\gcd(a, b) = \frac{b}{u}$  and  $\gcd(a, c) = \frac{c}{v}$  for some positive integers  $u, v$  and we have

$$\frac{b}{u} + \frac{c}{v} + \gcd(b, c) = b + c + 2023.$$

We want to prove  $u = v = 1$  so we need to eliminate other options. We do this by considering some cases.

1 point.

**Case I.** Both  $u$  and  $v$  are greater than 1.

In this case, we have  $\gcd(a, b) \leq \frac{b}{2}$  and  $\gcd(a, c) \leq \frac{c}{2}$ , so we must have  $\gcd(b, c) > \frac{b+c}{2}$ . However,  $\gcd(b, c)$  is a divisor of  $b$  and  $c$  so it is not greater than any of them and thus can't exceed their average, so we get a contradiction.

4 points.

**Case II.**  $u = 1$  and  $v > 1$ .

In this case, we have

$$b + \frac{c}{v} + \gcd(b, c) = b + c + 2023,$$

which can be rewritten as

$$\gcd(b, c) = c + 2023 - \frac{c}{v}.$$

Since  $c - \frac{c}{v} \geq \frac{c}{2}$ , we have  $\gcd(b, c) \geq \frac{c}{2} + 2023$ , so it is a divisor of  $c$  greater than  $\frac{c}{2}$ . Thus, it must be equal to  $c$ , so we conclude that  $c$  divides  $b$ . However, note that  $b \mid a$  since  $\gcd(a, b) = b$ , so we have  $c \mid b \mid a$  which implies  $c \mid a$ . But then  $\gcd(a, c) = c$ , i.e.  $v = 1$ , a contradiction.

**Case III.**  $u > 1$  and  $v = 1$ .

This case is analogous to Case II, so we don't need to consider it.

4 points.

**Notes on marking:**

- The points are all additive.

**Problem 2.** Let  $n \geq 5$  be an integer. There are  $n$  points in the plane, no three of them collinear. Each day, Tom erases one of the points, until there are three points left. On the  $i$ -th day, for  $1 \leq i \leq n - 3$ , before erasing that day's point, Tom writes down the positive integer  $v(i)$  such that the convex hull of the points at that moment has  $v(i)$  vertices. Finally, he writes down  $v(n - 2) = 3$ . Find the greatest possible value that the expression

$$|v(1) - v(2)| + |v(2) - v(3)| + \dots + |v(n - 3) - v(n - 2)|$$

can obtain among all possible initial configurations of  $n$  points and all possible Tom's moves.

*Remark.* A convex hull of a finite set of points in the plane is the smallest convex polygon containing all the points of the set (inside it or on the boundary).

*(Ivan Novak, Namik Agić)*

**Solution.** The answer is  $2n - 8$ . The construction which achieves the bound is the following:

Take a semicircle  $\Omega$  and mark  $n - 1$  points on it as  $B_1, \dots, B_{n-1}$ , in that order. Mark  $A$  as the intersection of tangents to  $\Omega$  at  $B_1, B_{n-1}$  and consider  $A$  and  $B_i$  as  $n$  starting points. In the first move, erase  $A$ , and after the first move erase  $B_i$  in arbitrary order. It is easy to check that the first summand is  $n - 4$  and the remaining  $n - 4$  summands are 1, giving the desired bound.

**3 points.**

The proof of the bound is as follows:

The key idea is to look at the contributions of the individual vertices to the sum. We will prove that each vertex  $X$  has a contribution at most 2 to the sum. This is more or less immediate, the first possible contribution is when it becomes a vertex on a convex hull, and a second possible contribution is when it is erased from the hull (The sums after and before these 2 events are not affected by  $X$ , as well as between). Moreover, the points on an initial hull lose 1 possible contribution, and points of the final hull lose 1 possible contribution (consequence of the possibilities for contribution of a vertex).

**3 points.**

Let  $z = v(1)$ . From this we get an upper bound in contributions  $2n - z - 3$  (Trivially,  $z$  is at least 3), Now we split into 2 cases to further sharpen this:

**1 point.**

- If there exists an index  $i$  such that  $v(i) < v(i + 1)$ , let  $A$  be the erased vertex and let  $B_1, \dots, B_k$  be the new vertices on the hull. The contributions from  $A$  and  $B_i$  for some  $i$  (WLOG say  $i = 1$ ) cancel out, bringing the total bound of contributions to  $2n - 3 - 3 - 2 = 2n - 8$ .

**2 points.**

- If there is no such  $i$ , we get the bound of  $n - 3$  (as  $v(i + 1) \geq v(i) - 1$ ), and because  $n \geq 5$ , we also get an upper bound of  $2n - 8 \geq n - 3$ .

**1 point.**

In both cases we obtain the desired upper bound and the proof is complete.

**Notes on marking:**

- If a solution does not discuss the case where  $v(i)$  is strictly decreasing (i.e. misses the discussion as in second bullet point), **1 point** should be deducted.

**Problem 3.** Consider an acute-angled triangle  $ABC$  with  $|AB| < |AC|$ . Let  $M$  and  $N$  be the midpoints of segments  $\overline{BC}$  and  $\overline{AB}$ , respectively. The circle with diameter  $\overline{AB}$  intersects the lines  $BC$ ,  $AM$  and  $AC$  at  $D$ ,  $E$ , and  $F$ , respectively. Let  $G$  be the midpoint of  $\overline{FC}$ . Prove that the lines  $NF$ ,  $DE$  and  $GM$  are concurrent.

(Michal Pecho)

**Solution.** Let  $A'$  be the reflection of  $A$  across  $M$ , and let  $F'$  be the reflection of  $F$  across  $N$ . Easy angle chase gives that  $D$  and  $F$  are feet of altitudes from  $A, B$  respectively.

**1 point.**

First,  $\angle DCA' = \angle ABC = \angle DEA'$ , meaning that  $DECA'$  is cyclic. As  $NF = NA$ ,  $FB \parallel AC \parallel BA'$ , which gives  $F, B, A'$  collinear. Now we have  $\angle F'FA = \angle BAC = \angle CA'B = \angle CA'F$ , which yields  $F'FCA'$  cyclic. =1

**3+3 point.**

From the radical center theorem on  $(BDEFA)$ ,  $(DECA')$ ,  $(F'FCA')$  we know that  $CA', FF', DE$  are concurrent. Let  $Z$  be the point of concurrency.

**2 points.**

As  $\angle F'FC = \angle FCA'$ , we get that  $\angle ZFC = \angle ZCF$ , i.e.  $Z$  lies on the perpendicular bisector of  $FC$ . But this bisector is exactly  $GM$  (as  $MF = MC$  and  $GF = GC$ ). Finally,  $Z$  also lies on  $GM$  and the three lines from the statement are indeed concurrent at  $Z$

**1 point.**

**Notes on marking:**

- There is a projective approach to the problem, sketched in a marking scheme. Other computational methods seem hard to execute. For partial non-synthetic solutions, only the parts which are geometric interpretations will be awarded points.
- If the solution marks the additional points as in the above, points will be given only for obtaining useful results, not solely on marking them.

**Problem 4.** We say a 2023-tuple of nonnegative integers  $(a_1, a_2, \dots, a_{2023})$  is *sweet* if the following conditions hold:

- $a_1 + a_2 + \dots + a_{2023} = 2023$ ,
- $\frac{a_1}{2^1} + \frac{a_2}{2^2} + \dots + \frac{a_{2023}}{2^{2023}} \leq 1$ .

Determine the greatest positive integer  $L$  such that

$$a_1 + 2a_2 + \dots + 2023a_{2023} \geq L$$

holds for every sweet 2023-tuple  $(a_1, a_2, \dots, a_{2023})$ .

(Ivan Novak)

**Solution.** Let  $a_1, a_2, \dots$  be a sweet sequence for which the least value  $L$  of  $a_1 + 2a_2 + 3a_3 + \dots$  is achieved.

Suppose that there are two nonconsecutive indices  $i < k$  with  $a_i, a_k > 0$ .

Consider the sequence

$$(a_1, a_2, \dots, a_{i-1}, a_i - 1, a_{i+1} + 2, a_{i+2}, \dots, a_{k-1}, a_k - 1, a_{k+1}, \dots),$$

i.e. the sequence in which the  $i$ -th and  $k$ -th term are reduced by 1 and the  $i + 1$ -th term is increased by 2.

We claim that this sequence is also sweet and that it achieves the value not greater than  $L$ .

The sum of its elements is unchanged so the first condition is satisfied.

For the second condition, note that

$$\frac{a_i - 1}{2^i} + \frac{a_{i+1} + 2}{2^{i+1}} + \frac{a_k - 1}{2^k} = \frac{a_i}{2^i} + \frac{a_{i+1}}{2^{i+1}} + \frac{a_k}{2^k} - \frac{1}{2^k},$$

so the sum in the second condition decreases, so it remains smaller than 1.

Finally, we claim that the value of the sum we're minimising didn't increase. Indeed, we have

$$i(a_i - 1) + (i + 1)(a_{i+1} + 2) + k(a_k - 1) = ia_i + (i + 1)a_{i+1} + ka_k - (k - i - 2),$$

and since  $k \geq i + 2$ , this means the sum didn't increase.

Repeating this transformation finitely many times, we obtain a sequence which obtains the minimum and which doesn't have two nonconsecutive indices  $i < k$  with  $a_i, a_k > 0$ . Thus, it suffices to check sequences of the form

$$(0, 0, \dots, 0, a, b, 0, 0, \dots),$$

with  $i - 1$  leading zeroes for some positive integer  $i$ , and with  $a > 0, b \geq 0$ .

**6 points.**

In this case, we have the conditions

$$\begin{aligned} a + b &= 2023, \\ 2a + b &\leq 2^{i+1}, \end{aligned}$$

and we're minimising the expression

$$f(a, b, i) = ia + (i + 1)b = 2023i + b.$$

Since  $0 \leq b < 2023$ , the optimal value of  $i$  is the least one for which the two conditions can be satisfied. We must have  $2^{i+1} = 2a + b > 2023$ , which holds if and only if  $i + 1 \geq 11$ , i.e. we must check  $i = 10$ .

**3 points.**

When  $i = 10$ , we have  $a + b = 2023, 2a + b \leq 2048$ , which gives  $b \geq 1998$ , or

$$10a + 11b \geq 20230 + 1998 = 22228.$$

This value can be obtained for  $a = 25$  and  $b = 1998$ , so we conclude that  $L = 22228$ .

**1 point.**

### Notes on marking:

- In the first part worth 6 points, 2 points will be awarded if the solution states that we can WLOG have equality in (2).
- Failed attempts of smoothing the sequence will be worth points depending on how close is it to the correct one (1 or 2 points). If it also contains first remark, the total sum is 1+pts on smoothing (not completely additive with smoothing)

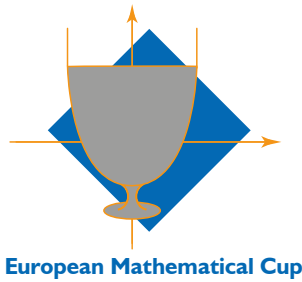

Enjoy solving complex problems using creative mathematical thinking? So do we!

Visit [www.janestreet.com](http://www.janestreet.com) to learn more about our educational programs, internships and full-time roles.

And of course - **Good Luck!**

Voliš rješavati teške probleme koristeći kreativno matematičko razmišljanje? I mi!

Posjeti [www.janestreet.com](http://www.janestreet.com) gdje možeš saznati više o edukacijama, stažiranjima i prilikama za zaposlenje.

I naravno - **Puno sreće!**

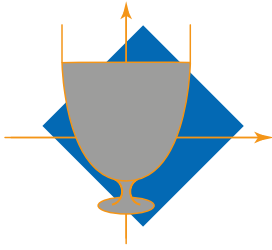

12<sup>TH</sup> EUROPEAN MATHEMATICAL CUP  
9<sup>th</sup> December 2023 - 17<sup>th</sup> December 2023



Senior Category

**Problem 1.** Determine all sets of real numbers  $S$  such that:

- 1 is the smallest element of  $S$ ,
- for all  $x, y \in S$  such that  $x > y$ ,  $\sqrt{x^2 - y^2} \in S$ .

(Adian Anibal Santos Sepčić)

**Problem 2.** Let  $ABC$  be a triangle such that  $\angle BAC = 90^\circ$ . The incircle of triangle  $ABC$  is tangent to the sides  $\overline{BC}$ ,  $\overline{CA}$ ,  $\overline{AB}$  at  $D$ ,  $E$ ,  $F$  respectively. Let  $M$  be the midpoint of  $\overline{EF}$ . Let  $P$  be the projection of  $A$  onto  $BC$  and let  $K$  be the intersection of  $MP$  and  $AD$ . Prove that the circumcircles of triangles  $AFE$  and  $PDK$  have equal radius.

(Kyprianos-Iason Prodromidis)

**Problem 3.** Let  $n$  be a positive integer. Let  $B_n$  be the set of all binary strings of length  $n$ . For a binary string  $s_1s_2 \dots s_n$ , we define its twist in the following way. First, we count how many blocks of consecutive digits it has. Denote this number by  $b$ . Then, we replace  $s_b$  with  $1 - s_b$ . A string  $a$  is said to be a *descendant* of  $b$  if  $a$  can be obtained from  $b$  through a finite number of twists. A subset of  $B_n$  is called *divided* if no two of its members have a common descendant. Find the largest possible cardinality of a divided subset of  $B_n$ .

*Remark.* Here is an example of a twist:  $10110 \rightarrow 10100$  because  $1|0|11|0$  has 4 blocks of consecutive digits.

(Viktor Simjanoski)

**Problem 4.** Let  $f : \mathbb{N} \rightarrow \mathbb{N}$  be a function such that for all positive integers  $x$  and  $y$ , the number  $f(x) + y$  is a perfect square if and only if  $x + f(y)$  is a perfect square. Prove that  $f$  is injective.

*Remark.* A function  $f : \mathbb{N} \rightarrow \mathbb{N}$  is injective if for all pairs  $(x, y)$  of distinct positive integers,  $f(x) \neq f(y)$  holds.

(Ivan Novak)

Time: 240 minutes.

Each problem is worth 10 points.

The use of calculators or any other instruments except rulers and compasses is not permitted.

Cheating in any form is strictly prohibited. Sharing or posting the problems or solutions before the end of the competition (18th of December) to anyone who might participate is strictly prohibited.

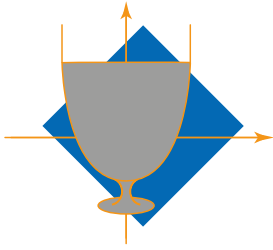

PROBLEMS AND SOLUTIONS OF THE  
12<sup>TH</sup> EUROPEAN MATHEMATICAL CUP  
9<sup>th</sup> December 2023 - 17<sup>th</sup> December 2023



Senior Category

**Problem 1.** Determine all sets of real numbers  $S$  such that:

- 1 is the smallest element of  $S$ ,
- for all  $x, y \in S$  such that  $x > y$ ,  $\sqrt{x^2 - y^2} \in S$ .

*(Adian Anibal Santos Sepčić)*

**Solution.** All such sets are the set  $\sqrt{\mathbb{N}} = \{\sqrt{n} \mid n \in \mathbb{N}\}$  and the sets  $\sqrt{[n]} = \{\sqrt{k} \mid k \leq n, k \in \mathbb{N}\}$  for any  $n \in \mathbb{N}$ . It's easy to check that all such sets satisfy the problem's condition.

**1 point.**

We will now show that any  $S$  that satisfies the two conditions of the problem is of this form. It suffices to show that  $S$  can only contain square roots of positive integers and that  $\sqrt{n} \in S$  implies that  $\sqrt{m} \in S$  for any  $m \leq n$ .

First, note that we have  $1 \in S$  so for any  $x \in S$  with  $x > 1$  we have  $\sqrt{x^2 - 1} \in S$ . Repeated application of this gives that  $\sqrt{x^2 - n} \in S$  for any  $n \in \mathbb{N}$  such that  $n < x^2$ .

**3 points.**

Now, assume that some number  $x \in S$  is not the square root of an integer. We then immediately have  $0 < x^2 - [x^2] < 1$  as  $x^2$  is not an integer, and the above consideration gives that  $\sqrt{x^2 - [x^2]} \in S$  and is strictly less than 1, which is a contradiction with  $1 = \min(S)$ . Therefore, we conclude that any element of  $S$  has to be the square root of an integer.

**5 points.**

Now, take some  $\sqrt{n} \in S$ . The above consideration immediately gives  $\sqrt{n-1} \in S$  and we can conclude by induction that any smaller square root of an integer must also be a member of  $S$ , and we are done.

**1 point.**

**Notes on marking:**

- Any proof that shows that the members of  $S$  must necessarily be square roots of positive integers is worth 8 points. Of the other 2 points, one is assigned for correctly and completely writing the solution set, and one for noting that if  $\sqrt{n} \in S$ , then all smaller square roots  $\sqrt{m}$  must also be in  $S$ . This must be explicitly commented on.

**Problem 2.** Let  $ABC$  be a triangle such that  $\angle BAC = 90^\circ$ . The incircle of triangle  $ABC$  is tangent to the sides  $\overline{BC}$ ,  $\overline{CA}$ ,  $\overline{AB}$  at  $D$ ,  $E$ ,  $F$  respectively. Let  $M$  be the midpoint of  $\overline{EF}$ . Let  $P$  be the projection of  $A$  onto  $BC$  and let  $K$  be the intersection of  $MP$  and  $AD$ . Prove that the circumcircles of triangles  $AFE$  and  $PDK$  have equal radius.

(Kyprianos-Iason Prodromidis)

**First Solution.** Let  $S = EF \cap BC$ , and let  $I$  be the center of the incircle of  $\triangle ABC$  and let  $H$  be the orthocenter of  $\triangle DEF$ . Easy angle chase shows  $\angle FDE = 45^\circ$ , and hence we have  $DH = EF$  (both being equal to  $\frac{\sqrt{2}}{2}$  times the radius of the incircle of  $\triangle ABC$ ). Also, as  $DIAH$  is a parallelogram,  $AH \perp BC$  and  $DH \perp EF$  which give  $AHP$  collinear. Our goal is to show  $DKHP$  cyclic, because then diameters of the circles in question would be  $DH$  and  $EF$  respectively (latter because  $HP \perp DP$ ), which we showed are equal.

3 points.

The main claim is the following:  $IS \perp AD$  (This holds regardless of the right angle). One can prove it either via complex numbers (setting  $(DEF)$  as the unit circle) or by showing that  $AD$  is a polar of  $S$  with respect to the incircle of  $\triangle ABC$ . We will omit the proofs because the lemma is well-known.

Also,  $AMPS$  is cyclic because of the right angles at  $M, P$

2 points.

Now we have:

$$\angle HPK = \angle APM = \angle ASM = \angle ISM,$$

where the second equality follows from the  $AMPS$  being cyclic, the third equality follows from  $AEIF$  being a square, i.e.  $I$  is the reflection of  $A$  across  $EF$ .

2 points.

Using the lemma we have:

$$\angle ISM = \angle DAM = \angle KAM = \angle HDK,$$

where the first equality holds because  $IS \perp AD$  and  $SM \perp AM$ , and the last equality follows from  $DH \parallel AM$ .

2 points.

These 2 chains of equality show  $\angle HPK = \angle HDK$ , which exactly means  $HPDK$  is cyclic, and we conclude from the first paragraph.

1 point.

**Second Solution.** Let  $I$  be the circumcircle of  $DEF$ , notice that  $AEFI$  is a square. Let  $BC, EF$  meet at  $S$ . It is clear that  $AMKS$  is cyclic. Also  $A$  lies on the  $D$ -symmedian so since  $IS \perp AD$ , if  $IS, AD$  intersect at  $X$ , this point lies on the circumcircles of  $IEF, AMK$ .

3 points.

Let circles of  $DKL, AMK$  intersect at  $Y$ , it follows that  $\angle DLK = \angle DYK$ . But,  $\angle DLK = \angle KTD + \angle MSA = 90^\circ - \angle SDA + \angle MSA = \angle DSM = \angle MYK$ . It follows that  $Y$  is on  $DM$ .

2 points.

Now, we shall show that the feet of  $E$  and  $F$  on  $DF$  and  $DE$ , respectively lie on the circle of  $DKL$ . By the theorem of radical axis, if circles  $FMY, EAF$  meet at  $Z$ , then  $Z$  would be on  $DF$ . We also have  $\angle EZF = 90^\circ$ , since  $\angle EAF = 90^\circ$ . Analogously, if the circles of  $EMY, EAF$  meet at  $W$ , we can generate a similar result. Thus, the circles of  $DKL, DZW$  would be the same, i.e., identical. If  $H$  is the orthocenter of  $DEF$ , we have  $R_{DKL} = R_{DZW} = \frac{DH}{2} = \frac{IA}{2} = R_{AEF}$ , as desired.

5 points.

**Notes on marking:**

- Citing the lemma as well-known won't cause point loss.
- In all incomplete computational solutions, only the geometric facts derived from the calculations will be worth points.

**Problem 3.** Let  $n$  be a positive integer. Let  $B_n$  be the set of all binary strings of length  $n$ . For a binary string  $s_1s_2 \dots s_n$ , we define its twist in the following way. First, we count how many blocks of consecutive digits it has. Denote this number by  $b$ . Then, we replace  $s_b$  with  $1 - s_b$ . A string  $a$  is said to be a *descendant* of  $b$  if  $a$  can be obtained from  $b$  through a finite number of twists. A subset of  $B_n$  is called *divided* if no two of its members have a common descendant. Find the largest possible cardinality of a divided subset of  $B_n$ .

(Viktor Simjanoski)

**Solution.** For a string  $s$ , denote its twist by  $f(s)$ , and the number of blocks of consecutive digits it has by  $b(s)$ . Construct an undirected graph  $G$  on  $B_n$  with edges  $(s, f(s))$  for all  $s \in B_n$ , and note that the largest possible cardinality of a divided subset of  $B_n$  is the number of connected components of the graph.

Each connected component of  $G$  contains exactly one cycle, and we aim to show that each cycle in the graph has a length of exactly 2.

**1 point.**

Assume that there exists a cycle  $A \subseteq B_n$  which is not of length 2. First, fix some  $s \in A$ .

We wish to show that  $1 < b(s) < n$ . If we have  $b(s) = 1$ , then  $s$  is either the string with all ones or the string with all zeroes, and we can easily see that  $f(s) = f^3(s)$  and  $s \neq f(f(s))$ , which contradicts  $s \in A$ . Similarly, if  $b(s) = n$  then  $s$  is one of the two alternating strings and we arrive to the same conclusion.

**1 point.**

Now consider  $x = s_{b(s)-1}, y = s_{b(s)}, z = s_{b(s)+1}$ . A twist replaces  $y$  with  $1 - y$ , and depending on  $x, z$  changes  $b(s)$  in the following ways:

- if  $x = z \neq y$ , we have  $b(f(s)) = b(s) - 2$ .
- if  $x = y = z$ , we have  $b(f(s)) = b(s) + 2$ .
- if  $x \neq y = z$  or  $x = y \neq z$ , we have  $b(f(s)) = b(s)$  and moreover we see that  $f(f(s)) = s$  and the connected component of  $s$  has a cycle of length 2 so  $s \notin A$ .

We therefore see that if  $s \in A$ , we have  $b(f(s)) = b(s) \pm 2$ .

**1 point.**

Now, consider some  $s \in A$ . We then have  $f^k(s) = s$  for some  $k \in \mathbb{N}$ . Take  $s$  such that  $b(s) \geq b(f^m(s))$  for any  $1 \leq m < k$ , i.e. the element of the cycle with the largest number of blocks.

We have  $b(f(s)) = b(s) - 2 = b(f^{-1}(s))$  by maximality and the previous proof. Notice that the application of  $f$  only changes the positions in  $s$  which are of the same parity as  $b(s)$ . We can see (as  $b(s) = b(f^{-1}(s)) + 2$ ) that  $s_{b(s)-3} = s_{b(s)-1} \neq s_{b(s)-2}$  and by similar reasoning  $s_{b(s)-1} = s_{b(s)+1} \neq s_{b(s)}$ .

**1 point.**

Now, consider the least  $t > 0$  such that  $b(f^t(s)) = b(s)$ . By minimality of  $t$ , it follows that  $f^t(s)_{b(s)} = 1 - s_{b(s)}$  but as we have  $s_{b(s)+1} = 1 - s_{b(s)} = s_{b(s)-1}$  we obtain that  $b(f(f^t(s))) = b(s) + 2$  which contradicts the maximality of  $b(s)$  in  $A$ , so no such component  $A$  can exist.

**4 points.**

Now, let us count the possible cycles of length 2. Each cycle of length 2 occurs when we have  $f(f(s)) = s$  and  $b(s) = b(f(s))$ , which gives  $2 \leq b(s) \leq n - 1$ .

We count by fixing either the left or right of the position  $b(s) = k$  in a string  $s$  as one of  $k - 1$  "break" points between 0/1 blocks in the string  $s$  and then counting that the other  $k - 2$  block "breakpoints" can be assigned in  $\binom{n-3}{k-2}$  ways to the remaining  $n - 3$  spots between two symbols of  $s$ , with each assignment of blocks giving two distinct outcomes due to the choice of 0/1 in the starting block. This gives a total of

$$\sum_{k=2}^{n-1} 2 \binom{n-3}{k-2} = 2^{n-2}$$

different cycles of length 2 and we are done.

**2 points.**

**Problem 4.** Let  $f : \mathbb{N} \rightarrow \mathbb{N}$  be a function such that for all positive integers  $x$  and  $y$ , the number  $f(x) + y$  is a perfect square if and only if  $x + f(y)$  is a perfect square. Prove that  $f$  is injective.

*Remark.* A function  $f : \mathbb{N} \rightarrow \mathbb{N}$  is injective if for all pairs  $(x, y)$  of distinct positive integers,  $f(x) \neq f(y)$  holds.  
(Ivan Novak)

**Solution.** Suppose for the sake of contradiction that there exist positive integers  $a, b$  and  $c$  such that  $f(a) = f(b) = c$  and  $a > b$ . Consider any  $x > \sqrt{c}$ .

Then, since  $x^2 - c + c = x^2 - c + f(a) = x^2 - c + f(b)$  is a square, both  $f(x^2 - c) + a$  and  $f(x^2 - c) + b$  are squares. Since  $a - b > 0$ , we have the following bound:

$$a - b = (f(x^2 - c) + a) - (f(x^2 - c) + b) > \sqrt{f(x^2 - c) + a} + \sqrt{f(x^2 - c) + b}.$$

This implies that the function  $x \mapsto f(x^2 - c)$  obtains only finitely many values since otherwise the bound wouldn't hold. By the pigeonhole principle, the expression  $f(x^2 - c)$  obtains some fixed value  $m$  for infinitely many positive integers  $x$ .

**1 point.**

Consider a positive integer  $y > \sqrt{m}$ . Then  $y^2 - m + f(x^2 - c) = y^2$  for infinitely many values of  $x$ . This implies that  $f(y^2 - m) + x^2 - c$  is a square for infinitely many values of  $x$ . This implies  $f(y^2 - m) - c = 0$ , since it can be written as a difference of squares in infinitely many ways. Thus,  $f(y^2 - m) = c$  for every  $y > \sqrt{m}$ .

**1 point.**

Now,  $f(y^2 - m) = c$  for infinitely many  $y$ , so with the same argumentation as above we get  $f(x^2 - c) = m$  for every  $x > \sqrt{c}$ .

**Lemma.** There exists a positive integer  $M$  such that for every positive integer  $z$  we have  $f(z) \leq M$  or  $f(z) \equiv m + 2 \pmod{4}$ .

*Proof.* If  $z = x^2 - c$  for some positive integer  $x$  then we have  $f(z) = m$ .

Now assume  $z \neq x^2 - c$  for all positive integers  $x$ .

Let  $y \in \mathbb{N}, y > \sqrt{m}$ . If  $f(z) + y^2 - m$  is a square, then  $z + f(y^2 - m)$  is a square, but  $f(y^2 - m) = c$ , so this is contradiction with the choice of  $z$ .

So  $f(z) + y^2 - m \neq x^2$  for all positive integers  $x$ .

From this, we have  $f(z) \neq x^2 - y^2 + m$  for all positive integers  $x$  i  $y$  such that  $y > \sqrt{m}$ .

Let  $y_1$  be the smallest positive integer such that  $y_1 > \sqrt{m}$ .

For every  $y \geq y_1$  we have  $f(z) \neq (y+1)^2 - y^2 + m = 2y+1+m$ , so  $f(z)$  is either smaller than  $2y_1+1+m$  or  $f(z) - m \not\equiv 1 \pmod{2}$ .

For every  $y \geq y_1$  we have  $f(z) \neq (y+2)^2 - y^2 + m = 4y+4+m$ , so  $f(z)$  is either smaller than  $4y_1+4+m$  or  $f(z) - m \not\equiv 0 \pmod{4}$ .

Now  $M = 4y_1 + 4 + m$  satisfies the claim of the lemma.

□

**5 points.**

Take  $M$  which satisfies the lemma. Now take  $w$  such that  $w+1, w+2, \dots, w+M$  are not squares, and  $w+m \equiv 0 \pmod{4}$ .

For some  $d > \sqrt{f(w)}$

we have  $d^2 - f(w) + f(w)$  is a square so  $f(d^2 - f(w)) + w$  must be a square, but using the lemma on  $z = d^2 - f(w)$  we get that  $f(d^2 - f(w)) + w$  is either among  $w+1, w+2, \dots, w+M$  or congruent  $2+m+w \equiv 2 \pmod{4}$ , so it cannot be a square.

Contradiction with the starting assumption, so  $f$  must be injective.

**3 points.**



# Statistics of the 12th European Mathematical Cup

9th Dec 2023 - 17th Dec 2023



## Junior Category

#	J1	J2	J3	J4
0	116	246	288	301
1	98	7	9	7
2	13	1	2	2
3	5	20	3	3
4	5	5	0	3
5	6	6	1	4
6	4	7	1	1
7	3	6	0	3
8	6	8	1	2
9	3	5	1	1
10	73	21	26	5
$\Sigma$	332	332	332	332
$\mu$	3.13	1.57	0.93	0.46
$\sigma$	4.04	3.09	2.78	1.75

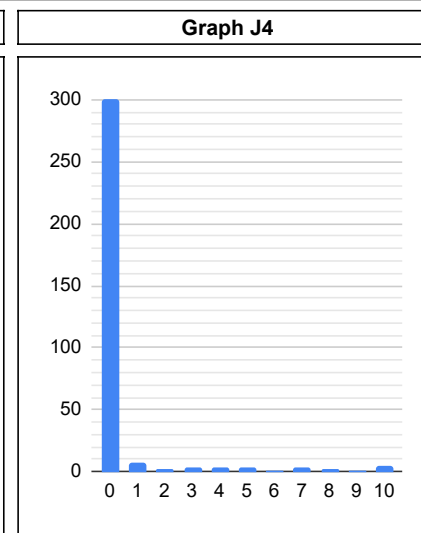
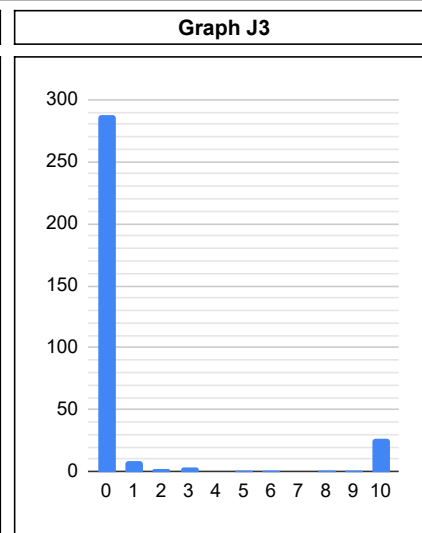
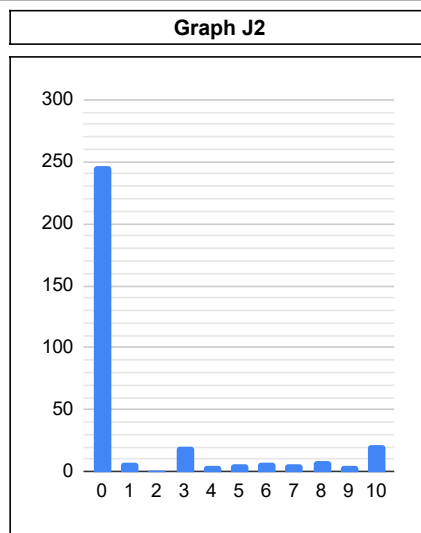
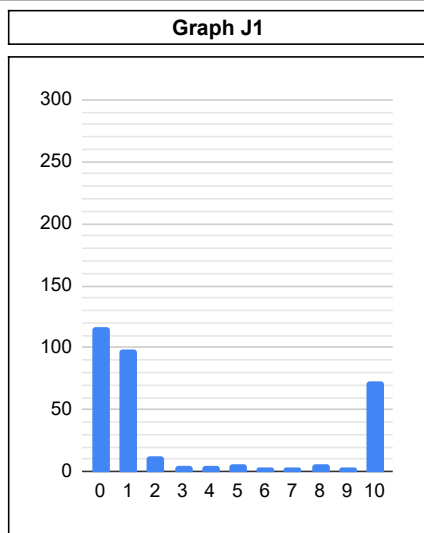

## Senior Category

#	S1	S2	S3	S4
0	49	228	234	278
1	4	12	39	38
2	3	12	16	25
3	32	17	12	1
4	4	2	4	1
5	16	9	6	0
6	4	1	7	1
7	8	1	4	7
8	26	4	8	0
9	101	4	8	0
10	118	75	27	14
$\Sigma$	365	365	365	365
$\mu$	7.07	2.66	1.72	0.79
$\sigma$	3.60	4.08	3.17	2.17

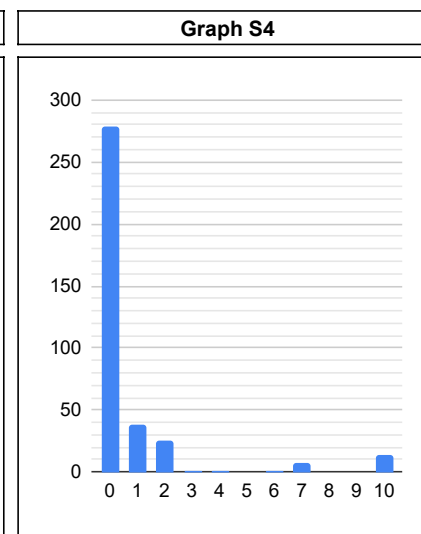
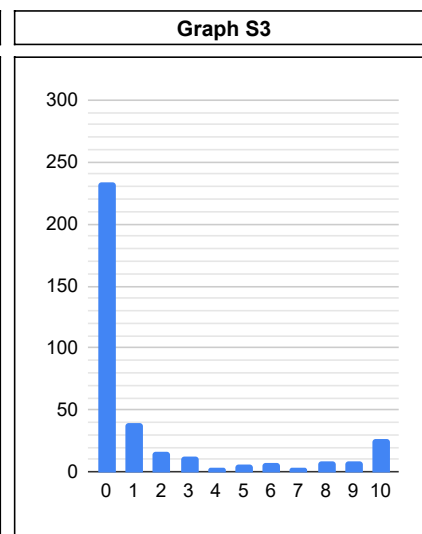
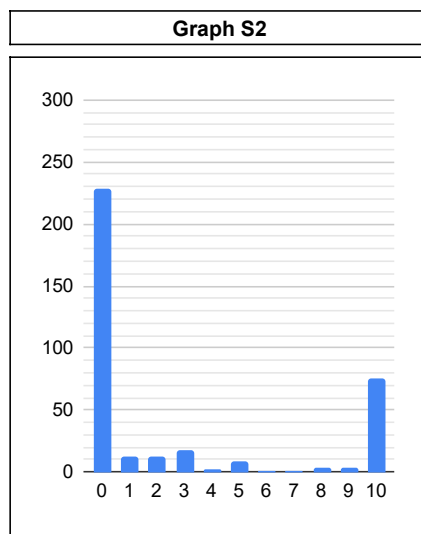
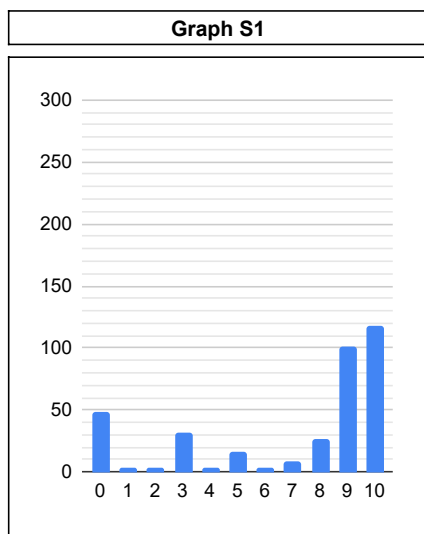

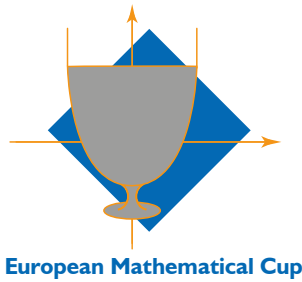

**Enjoy solving complex problems using creative mathematical thinking? So do we!**

Visit [www.janestreet.com](http://www.janestreet.com) to learn more about our educational programs, internships and full-time roles.

And of course - **Good Luck!**

**Voliš rješavati teške probleme koristeći kreativno matematičko razmišljanje? I mi!**

Posjeti [www.janestreet.com](http://www.janestreet.com) gdje možeš saznati više o edukacijama, stažiranjima i prilikama za zaposlenje.

I naravno - **Puno sreće!**

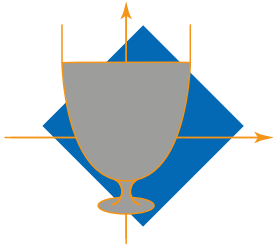

**13<sup>TH</sup> EUROPEAN MATHEMATICAL CUP**  
14<sup>th</sup> December 2024 - 22<sup>nd</sup> December 2024



Junior Category

**Problem 1.** Wiske wrote a 2024-digit positive integer on the blackboard. In each round of the game she erases the last digit of the integer, let this digit be  $d$ , and writes down the sum of the remaining number and  $2d$  in place of the old number. She repeats the same steps with the newly obtained number. After a certain number of rounds, Wiske found that the new number obtained was the same as the number in the last round and she stopped the game. What is the smallest possible 2024-digit integer that Wiske started with in this game?

*(Kai Chen)*

**Problem 2.** Let  $X$  be the largest possible value of the expression

$$\min\{bc, 2 - a^2\} + \min\{ac, 2 - b^2\} + \min\{ab, 2 - c^2\},$$

where  $a, b$  and  $c$  are positive real numbers. Similarly, let  $Y$  be the smallest possible value of the expression

$$\max\{a^2, 2 - bc\} + \max\{b^2, 2 - ac\} + \max\{c^2, 2 - ab\},$$

where  $a, b$  and  $c$  are positive real numbers. Prove that  $X = Y$ .

*(Ognjen Tešić)*

**Problem 3.** Let  $ABC$  be a triangle with incenter  $I$  and incircle  $\omega$ . Let  $\ell$  be the tangent to  $\omega$  parallel to  $BC$  and distinct from  $BC$ . Let  $D$  be the intersection of  $\ell$  and  $AC$ , and let  $M$  be the midpoint of  $ID$ . Prove that  $\angle AMD = \angle DBC$ .

*(Weihua Wang)*

**Problem 4.** Let  $\mathcal{F}$  be a family of (distinct) subsets of the set  $\{1, 2, \dots, n\}$  such that for all  $A, B \in \mathcal{F}$  we have that  $A^c \cup B \in \mathcal{F}$ , where  $A^c$  is the set of all members of  $\{1, 2, \dots, n\}$  that are not in  $A$ .

Prove that every  $k \in \{1, 2, \dots, n\}$  appears in at least half of the sets in  $\mathcal{F}$ .

*(Stijn Cambie, Mohammad Javad Moghaddas Mehr)*

Time: 240 minutes.

Each problem is worth 10 points.

*The use of calculators or any other instruments except rulers and compasses is not permitted.*

*Cheating in any form is strictly prohibited. Sharing or posting the problems or solutions before the end of the competition (22nd of December) to anyone who might participate is strictly prohibited.*

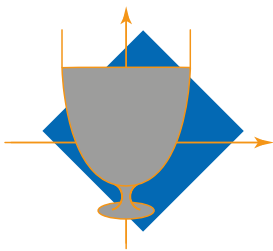

PROBLEMS AND SOLUTIONS OF THE  
13<sup>TH</sup> EUROPEAN MATHEMATICAL CUP  
14<sup>th</sup> December 2024 - 22<sup>nd</sup> December 2024



Junior Category

**Problem 1.** Wiske wrote a 2024-digit positive integer on the blackboard. In each round of the game she erases the last digit of the integer, let this digit be  $d$ , and writes down the sum of the remaining number and  $2d$  in place of the old number. She repeats the same steps with the newly obtained number. After a certain number of rounds, Wiske found that the new number obtained was the same as the number in the last round and she stopped the game. What is the smallest possible 2024-digit integer that Wiske started with in this game?

(Kai Chen)

**Solution.** Firstly, we claim that the last number Wiske obtained is 19.

In the last round, let the last digit of the number be  $d$  where  $0 \leq d \leq 9$ , and the remaining digits form an integer  $x$ . The number at the beginning of this round is then  $10x + d$ , and the new number obtained in this round is  $x + 2d$ . Since the two numbers are the same,  $10x + d = x + 2d$ , i.e.,  $9x = d$ .

Because  $0 \leq d \leq 9$  and we cannot have  $x = d = 0$  because all newly written numbers are positive, the only solution is  $x = 1$  and  $d = 9$ . The last number is then 19.

**2 points.**

Secondly, we claim that the numbers in all previous rounds are divisible by 19. From  $2(10x + d) = 19x + (x + 2d)$ , it follows that  $2(10x + d) \equiv x + 2d \pmod{19}$ . Since the last number is 19, it can be concluded by reverse induction that the numbers in all rounds of the game are divisible by 19.

**3 points.**

From the same induction we get that the number Wiske started with being divisible by 19 is a sufficient condition as well.

**1 point.**

Finally, our goal is to find the smallest 2024-digit number which is divisible by 19 because the sequence of the numbers in all rounds is strictly descending:

$$10x + d > x + 2d, \text{ if } x > 1.$$

Per the Fermat's Little Theorem, we get  $10^{18} \equiv 1 \pmod{19}$ . We have,

$$10^{2023} \equiv 10^7 \pmod{19}, \text{ because } 2023 = 112 \times 18 + 7.$$

$$10^7 = 100^3 \times 10 \equiv 5^3 \times 10 = 1250 \equiv 15 \pmod{19}.$$

$$10^{2023} + 4 \equiv 0 \pmod{19}.$$

**3 points.**

Thus,  $10^{2023} + 4$  is the smallest 2024-digit number which is divisible by 19. It is the smallest possible 2024-digit integer that Wiske started with in the game.

**1 point.**

**Problem 2.** Let  $X$  be the largest possible value of the expression

$$\min\{bc, 2 - a^2\} + \min\{ac, 2 - b^2\} + \min\{ab, 2 - c^2\},$$

where  $a, b$  and  $c$  are positive real numbers. Similarly, let  $Y$  be the smallest possible value of the expression

$$\max\{a^2, 2 - bc\} + \max\{b^2, 2 - ac\} + \max\{c^2, 2 - ab\},$$

where  $a, b$  and  $c$  are positive real numbers. Prove that  $X = Y$ .

(Ognjen Tešić)

**First Solution.** Observe that  $\min\{bc, 2 - a^2\} = 2 + \min\{bc - 2, -a^2\} = 2 - \max\{-(bc - 2), a^2\} = 2 - \max\{2 - bc, a^2\}$ , so  $X = Y$  is equivalent to

$$\begin{aligned} \min \left\{ \sum_{cyc} \max\{a^2, 2 - bc\} \right\} &= \max \left\{ \sum_{cyc} \min\{bc, 2 - a^2\} \right\} \\ \Leftrightarrow \min \left\{ \sum_{cyc} \max\{a^2, 2 - bc\} \right\} &= \max \left\{ \sum_{cyc} 2 - \max\{2 - bc, a^2\} \right\} \\ \Leftrightarrow \min \left\{ \sum_{cyc} \max\{a^2, 2 - bc\} \right\} &= 6 + \max \left\{ - \sum_{cyc} \max\{2 - bc, a^2\} \right\} \\ \Leftrightarrow \min \left\{ \sum_{cyc} \max\{a^2, 2 - bc\} \right\} &= 6 - \min \left\{ \sum_{cyc} \max\{2 - bc, a^2\} \right\} \\ \Leftrightarrow \min \left\{ \sum_{cyc} \max\{a^2, 2 - bc\} \right\} &= 3 \end{aligned}$$

3 points.

For  $a = b = c = 1$  we get that  $\min \left\{ \sum_{cyc} \max\{a^2, 2 - bc\} \right\} \leq 3$ , so we need to show that

$$\sum_{cyc} \max\{a^2, 2 - bc\} \geq 3$$

1 point.

but since  $\max\{x, y\} \geq \frac{x+y}{2}$  we have that

2 points.

$$\sum_{cyc} \max\{a^2, 2 - bc\} \geq \sum_{cyc} \frac{a^2 + 2 - bc}{2} = 3 + \frac{1}{2} \left( \sum_{cyc} a^2 - \sum_{cyc} bc \right) = 3 + \frac{1}{2} \left( \sum_{cyc} \frac{b^2 + c^2}{2} - \sum_{cyc} bc \right) \geq 3 + \frac{1}{2} \left( \sum_{cyc} bc - \sum_{cyc} bc \right) = 3$$

4 points.

**Second Solution.** An alternative proof of the last inequality. Suppose, for the sake of contradiction, that

$$\sum_{cyc} \max\{a^2, 2 - bc\} < 3$$

but since  $\min\{a^2, 2 - bc\} \leq \max\{a^2, 2 - bc\}$  we have that

$$\sum_{cyc} \min\{a^2, 2 - bc\} \leq \sum_{cyc} \max\{a^2, 2 - bc\} < 3$$

by adding the two inequalities we get

$$\sum_{cyc} \max\{a^2, 2 - bc\} + \max\{a^2, 2 - bc\} < 6$$

1 point.

now we use the fact that  $\min\{x, y\} + \max\{x, y\} = x + y$

1 point.

to get that

$$\sum_{cyc} a^2 + 2 - bc < 6,$$

contradiction by AG inequality as in the First Solution.

4 points.

**Problem 3.** Let  $ABC$  be a triangle with incenter  $I$  and incircle  $\omega$ . Let  $\ell$  be the tangent to  $\omega$  parallel to  $BC$  and distinct from  $BC$ . Let  $D$  be the intersection of  $\ell$  and  $AC'$ , and let  $M$  be the midpoint of  $ID$ . Prove that  $\angle AMD = \angle DBC$ .

(Weihua Wang)

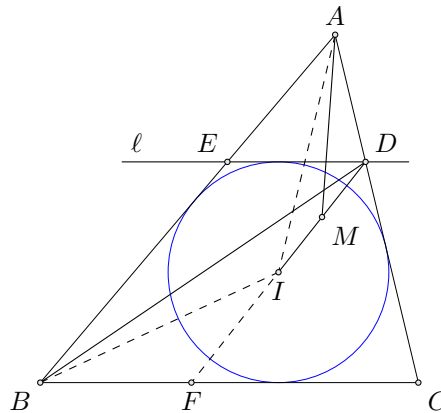

**First Solution.** Let  $E$  be the intersection point of line  $\ell$  with  $AB$ , and let  $F$  be the intersection point of  $DI$  with  $BC$ . Since  $\ell \parallel BC$  and  $\ell$  is tangent to circle  $\omega$ , we have

$$\angle CDI = \angle EDI = \angle CFI = 90^\circ - \frac{C}{2},$$

$$\angle ADI = \angle BFI = 90^\circ + \frac{C}{2} = \angle AIB.$$

2 points.

Noting that  $\angle DAI = \angle BAI$  and  $\angle ABI = \angle FBI$ , we obtain  $\triangle ADI \sim \triangle AIB \sim \triangle IFB$ . Therefore,

2 points.

$$\frac{AD}{DI} = \frac{IF}{FB} \Rightarrow \frac{AD}{DM} = \frac{2AD}{DI} = \frac{2IF}{BF} = \frac{DF}{BF}.$$

4 points.

Thus,  $\triangle AMD \sim \triangle DBF$ , so  $\angle AMD = \angle DBC$ .

2 points.

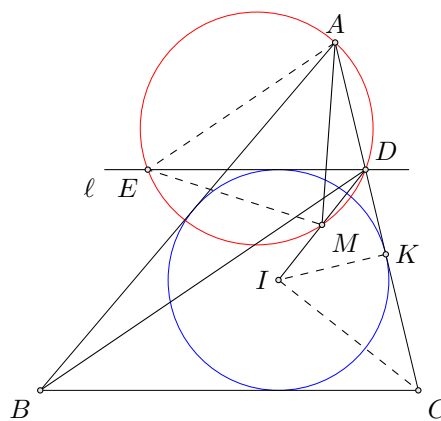

**Second Solution.** Let  $BC = a$ ,  $CA = b$ ,  $AB = c$ , and let the inradius of  $\triangle ABC$  be  $r$ . Suppose  $\omega$  is tangent to  $AC$  at  $K$ , and let line  $\ell$  intersect the circumcircle of  $\triangle ADM$  again at  $E$ . Let the area of  $\triangle ABC$  be  $S$ . Then, from the formula

$$S = \frac{1}{2}(a + b + c) \cdot r = \frac{1}{2}ab \sin C,$$

we have

$$\frac{a + b + c}{a} = \frac{b \sin C}{r} \Rightarrow \frac{(b + c - a)/2 + a}{a} = \frac{b}{(2r)/\sin C},$$

**2 points.**

which implies

$$\frac{AK + BC}{BC} = \frac{AC}{CD} \Rightarrow \frac{AK}{BC} = \frac{AD}{CD}.$$

**2 points.**

Noting that  $\angle AEM = \angle CDI = \angle EDI = \angle EAM = 90^\circ - \frac{C}{2}$ , we conclude  $ME = MA$ . Applying Ptolemy's theorem to quadrilateral  $ADME$  and noting that  $AE = 2AM \cdot \sin \frac{C}{2}$ , we get

$$AM \cdot DE = EM \cdot AD + AE \cdot DM = AM \cdot AD + 2AM \cdot \sin \frac{C}{2} \cdot DM.$$

**3 points.**

Thus,

$$DE = AD + 2DM \cdot \sin \frac{C}{2} = AD + DI \cdot \sin \frac{C}{2} = AD + DK = AK.$$

**1 point.**

Therefore,  $\frac{DE}{BC} = \frac{AD}{CD}$ , which implies  $\triangle AED \sim \triangle DBC$ . Hence,  $\angle AMD = \angle AED = \angle DBC$ .

**2 points.**

**Problem 4.** Let  $\mathcal{F}$  be a family of (distinct) subsets of the set  $\{1, 2, \dots, n\}$  such that for all  $A, B \in \mathcal{F}$  we have that  $A^c \cup B \in \mathcal{F}$ , where  $A^c$  is the set of all members of  $\{1, 2, \dots, n\}$  that are not in  $A$ .

Prove that every  $k \in \{1, 2, \dots, n\}$  appears in at least half of the sets in  $\mathcal{F}$ .

(Stijn Cambie, Mohammad Javad Moghaddas Mehr)

**First Solution.** We start out by “cleaning up” our set family. We denote  $[n] = \{1, 2, \dots, n\}$ , and refer to it as the *ground set*.

Firstly, if there exists a number  $x \in \{1, 2, \dots, n\}$  which appears in every member of the family  $\mathcal{F}$ , remove it from all members of the family. Proving the claim of the problem for the remaining family clearly suffices, as  $x$  is in all sets of the family, and so in at least half of them.

**0 points.**

Additionally, while there exist two elements  $x, y$  such that for every  $A \in \mathcal{F}$  we have

$$x \in A \iff y \in A$$

remove one of them from all the sets of the family, and do this until no such pairs remain. Proving the problem claim for the remaining family of sets clearly suffices, as every removed number has a corresponding number that is still in the ground set and appears in exactly as many sets of the family as the removed member originally did.

**1 point.**

Now, fix any pair of distinct elements  $\{x, y\}$  of the ground set. We wish to show that there exist sets  $A_{x,y}, A_{y,x} \in \mathcal{F}$  such that  $x \in A_{x,y}, x \notin A_{y,x}$  and  $y \in A_{y,x}, y \notin A_{x,y}$ . As we ensured that  $x, y$  do not always appear together, one of them must exist. Assume without loss of generality that it is  $A_{x,y}$ .

Assuming that any set  $A_{y,x} \in \mathcal{F}$  containing  $y$  but not  $x$  does not exist, this implies that for every  $A \in \mathcal{F}$  we have

$$x \in A \implies y \in A.$$

Now, as  $y$  is not in every set of  $\mathcal{F}$ , there exists a set  $B$  such that  $y \notin B$  and the previous implication implies that  $x \notin B$ . However, if we now consider the set  $A_{x,y}^c \cup B \in \mathcal{F}$ , it contains  $y$  but does not contain  $x$ , contradicting the nonexistence of a suitable  $A_{y,x} \in \mathcal{F}$ .

**2 points.**

We now aim to show that for every  $x \in [n]$ , we have that  $\{x\}^c \in \mathcal{F}$ . Fix one such  $x$ , take some set  $B \in \mathcal{F}$  such that  $x \notin B$  and consider the set

$$B \cup \bigcup_{y \neq x} A_{x,y}^c.$$

This set contains all elements  $y \neq x$ , so it must be equal to  $\{x\}^c$ . It is a member of  $\mathcal{F}$  by repeated  $n - 1$ -fold application of the condition on members of  $\mathcal{F}$ .

**4 points.**

To finish, consider some  $x \in [n]$  and some  $B \in \mathcal{F}$  not containing  $x$ . We then have that  $\{x\} \cup B \in \mathcal{F}$ , so for every set in  $\mathcal{F}$  that does not contain  $x$  we can find a unique one that does and we are done.

**3 points.**

**Second Solution.** First we observe that for  $A, B \in \mathcal{F}$  by using the rule on  $A^c \cup B$  and  $B$  we get that

$$(A^c \cup B)^c \cup B = (A \cap B^c) \cup B = (A \cup B) \cap (B^c \cup B) = A \cup B \in \mathcal{F}. \tag{1}$$

**2 points.**

Now we take an arbitrary  $x \in [n]$ , let  $\mathcal{A} = \{S \in \mathcal{F} : x \in S\}$  and  $\mathcal{B} = \{S \in \mathcal{F} : x \notin S\}$ . Then the set  $T := \bigcup_{S \in \mathcal{B}} S$  is in  $\mathcal{F}$  by using (1). Note that  $x \notin T$  and that every  $S \in \mathcal{B}$  is a subset of  $T$ .

**3 points.**

Now we'll prove that the function  $f : \mathcal{B} \rightarrow \mathcal{A}$  defined by  $f(S) = T^c \cup S$  is an injection.

**3 points.**

Suppose there exists  $B_1, B_2 \in \mathcal{B}$  such that  $T^c \cup B_1 = T^c \cup B_2$

$$\begin{aligned} &\implies T \cap (T^c \cup B_1) = T \cap (T^c \cup B_2) \\ &\implies (T \cap T^c) \cup (T \cap B_1) = (T \cap T^c) \cup (T \cap B_2) \\ &\implies \emptyset \cup B_1 = \emptyset \cup B_2 \\ &\implies B_1 = B_2 \end{aligned}$$

where the third implication holds since  $B_1, B_2 \subseteq T$ . So  $f$  is injective  $\implies |\mathcal{A}| \geq |\mathcal{B}|$ .

**2 points.**

**Third Solution.** Obtain that for no two elements  $x, y \in [n]$  holds  $x \in A \iff y \in A$  for every  $A \in \mathcal{F}$  as in the first solution.

**1 point.**

For arbitrary  $x$ , let  $T$  be the largest set not containing  $x$ . We claim  $T = \{x\}^c$ .

Assume the opposite, then every set  $A \in \mathcal{F}$  containing  $x$  needs to contain  $T^c$  because otherwise  $|A^c \cup T| > |T|$ .

**2 points.**

Show that for any two sets  $A, B \in \mathcal{F}$  their union  $A \cup B \in \mathcal{F}$  is also in the family as shown in the Second Solution.

**2 points.**

If  $A \in \mathcal{F}$  contains an element of  $T^c$ , then  $|A \cup T^c| > |T|$  so  $A$  must contain  $x$ .

**1 point.**

These two combined imply that  $x, y \in T^c$  belong to the exact same sets in  $\mathcal{F}$  which is a contradiction with the claim at the beginning.

**1 point.**

Since we have  $\{x\}^c \in \mathcal{F}$  we can finish the solution as in the First Solution.

**3 points.**

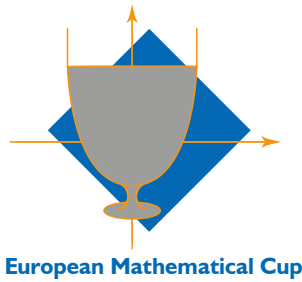

Enjoy solving complex problems using creative mathematical thinking? So do we!

Visit [www.janestreet.com](http://www.janestreet.com) to learn more about our educational programs, internships and full-time roles.

And of course - **Good Luck!**

Voliš rješavati teške probleme koristeći kreativno matematičko razmišljanje? I mi!

Posjeti [www.janestreet.com](http://www.janestreet.com) gdje možeš saznati više o edukacijama, stažiranjima i prilikama za zaposlenje.

I naravno - **Puno sreće!**

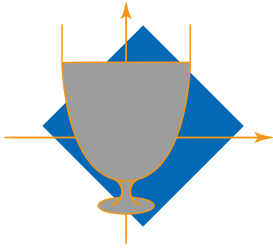

**13<sup>TH</sup> EUROPEAN MATHEMATICAL CUP**  
14<sup>th</sup> December 2024 - 22<sup>nd</sup> December 2024



Senior Category

**Problem 1.** We call a pair of distinct numbers  $(a, b)$  a *binary pair* if  $ab + 1$  is a power of two. Given a set  $S$  of  $n$  positive integers, what is the maximum possible number of binary pairs in  $S$ ?

(Oleksii Masalitin)

**Problem 2.** Let  $n$  be a positive integer. The numbers  $1, 2, \dots, 2n + 1$  are arranged in a circle in that order, and some of them are *marked*.

We define, for each  $k$  such that  $1 \leq k \leq 2n + 1$ , the interval  $I_k$  to be the closed circular interval starting at  $k$  and ending at  $k + n$  (taking remainders modulo  $2n + 1$  if  $k + n > 2n + 1$ ). We call an interval  $I_k$  *magical* if it contains strictly more than half of all the marked elements.

Prove that the following two statements are equivalent:

1. At least  $n + 1$  of the intervals  $I_1, I_2, \dots, I_{2n+1}$  are magical.
2. The number of marked numbers is odd.

(Andrei Constantinescu)

**Problem 3.** Let  $\omega$  be a semicircle with diameter  $\overline{AB}$  and let  $M$  be the midpoint of  $\overline{AB}$ . Let  $X, Y$  be points in the same half-plane as  $\omega$  with respect to the line  $AB$  such that  $AMXY$  is a parallelogram. Let  $I$  be the incenter of the triangle  $MX Y$ . Lines  $MX, MY$  intersect  $\omega$  in points  $C, D$  respectively. Let  $T$  be the intersection of  $AC$  and  $BD$ . The line  $MT$  intersects  $XY$  in  $E$ . If  $P$  is the intersection of  $EI$  and  $AB$ , and  $Q$  is the projection of  $E$  onto the line  $AB$ , show that  $M$  is the midpoint of  $\overline{PQ}$ .

(Michal Pecho)

**Problem 4.** Find all functions  $f: \mathbb{R}^+ \rightarrow \mathbb{R}^+$  such that

$$f(x + yf(x)) = xf(1 + y)$$

for all  $x, y \in \mathbb{R}^+$ .

*Remark.* We denote by  $\mathbb{R}^+$  the set of all positive real numbers.

(Ioannis Galamatis)

Time: 240 minutes.

Each problem is worth 10 points.

*The use of calculators or any other instruments except rulers and compasses is not permitted.*

*Cheating in any form is strictly prohibited. Sharing or posting the problems or solutions before the end of the competition (22nd of December) to anyone who might participate is strictly prohibited.*

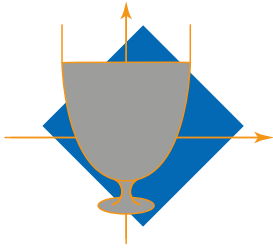

**PROBLEMS AND SOLUTIONS OF THE  
13<sup>TH</sup> EUROPEAN MATHEMATICAL CUP**  
14<sup>th</sup> December 2024 - 22<sup>nd</sup> December 2024



Senior Category

**Problem 1.** We call a pair of distinct numbers  $(a, b)$  a *binary pair* if  $ab + 1$  is a power of two. Given a set  $S$  of  $n$  positive integers, what is the maximum possible number of binary pairs in  $S$ ?

*(Oleksii Masalitin)*

**First Solution.** The answer is  $n - 1$ , achieved by choosing  $2^k - 1$  for  $1 \leq k \leq n$ . One can then easily see that  $1, 2^k - 1$  makes a binary pair for  $n \geq k > 1$ . For the bound, make a graph  $G$  with vertices  $a_1, \dots, a_n$ , and connect  $(a, b)$  if  $a, b$  makes a binary pair.

**2 points.**

The key is the following:

**Claim 1.**  $G$  does not contain a cycle.

*Proof.* Assume otherwise and suppose:

$$\begin{aligned} x_1x_2 + 1 &= 2^{a_1} \\ x_2x_3 + 1 &= 2^{a_2} \\ &\dots \\ x_nx_1 + 1 &= 2^{a_n} \end{aligned}$$

for positive integers  $a_1, \dots, a_n$  and  $n \geq 3$ . WLOG let  $a_1$  be the greatest (not necessarily unique). Notice that all  $x_i$  are odd, this is just parity. Focus on the following three equations:

$$x_nx_1 + 1 = 2^{a_n} \tag{1}$$

$$x_1x_2 + 1 = 2^{a_1} \tag{2}$$

$$x_2x_3 + 1 = 2^{a_2} \tag{3}$$

Subtracting (1) from (2) and (3) from (2) results in:

$$x_1(x_2 - x_n) = 2^{a_n}(2^{a_1 - a_n} - 1) \implies x_1 \mid 2^{a_1 - a_n} - 1 \text{ as } x_1 \text{ is odd}$$

$$x_2(x_1 - x_3) = 2^{a_2}(2^{a_1 - a_2} - 1) \implies x_2 \mid 2^{a_1 - a_2} - 1 \text{ as } x_2 \text{ is odd}$$

**3 points.**

The bound  $x_1x_2 + 1 < (x_nx_1 + 1)(x_2x_3 + 1)$  can be verified by simple expansion. In turn, this gives  $a_2 + a_n > a_1$

**3 points.**

Finally:

$$2^{a_1} - 1 = x_1x_2 \mid (2^{a_1 - a_2} - 1)(2^{a_1 - a_n} - 1) < 2^{a_1} - 2^{a_1 - a_2} - 2^{a_1 - a_n} + 1 \leq 2^{a_1} - 1$$

As  $(2^{a_1 - a_2} - 1)(2^{a_1 - a_n} - 1)$  is nonnegative, the divisibility can hold only if it is equal to 0. This would give  $a_1 = a_n$  or  $a_1 = a_2$ , contradicting  $x_n \neq x_2$  and  $x_1 \neq x_3$  respectively.

□

As a graph with  $n$  vertices not containing cycles can have at most  $n - 1$  edges, the proof of the bound is finished.

**2 points.**

**Second Solution.** Here we present an approach using Zsigmondy's theorem. Assume that  $T = \{b_1, \dots, b_k\}$  is the set of all indices with the maximal value of  $a_i$ , call it  $M$ . Observe that  $a_j$ -s in  $T$  must not be consecutive, otherwise they would violate the distinct  $x_i$  condition. Now we can multiply the equations to get the following:

$$\prod_{i \in T} (2^M - 1) \mid \prod_{i \notin T} (2^{a_i} - 1)$$

**2 points.**

We get a contradiction with Zsigmondy's theorem as  $2^M - 1$  has a primitive prime divisor not dividing  $2^n - 1$  for  $n < M$ , except for the case  $M = 6$

**4 points.**

. Assume  $x_i x_{i+1} = 63$  for some  $i$ .

- if  $x_i = 63$ , then  $x_{i+2} = 63$  as  $2^6$  is the greatest possible value, contradicting distinctness.
- if  $x_i = 21$ , one similarly gets  $x_{i+2} = 21$ , again a contradiction.
- the rest of the cases are similar and brute force

**2 points.**

**Third Solution.** Again, the construction and the comment is the same as in the first solution. For the bound, we claim the following:

If  $(a, b), (a, c)$  are two binary pairs with  $a > b, c$ , then  $b = c$ .

**1 point.**

*Proof.* WLOG assume  $b \geq c$ . As  $ac + 1$  and  $ab + 1$  are powers of 2, we have:

$$\begin{aligned} ac + 1 &\mid ab + 1 \\ ac + 1 &\mid a(b - c) \\ ac + 1 &\mid b - c \end{aligned}$$

**4 points.**

But, if  $b > c$ , then

$$0 < b - c < b < a < ac + 1$$

**2 points.**

, contradiction. □

Now, all elements of  $S$  except the smallest can be the larger element in at most one binary pair, giving the bound  $n - 1$

**1 point.**

**Comment:** One can show no cycles of odd length with little effort: All powers of 2 involved are at least 4. Now subtract one and multiply all equations together, and finish by mod 4.

**Problem 2.** Let  $n$  be a positive integer. The numbers  $1, 2, \dots, 2n + 1$  are arranged in a circle in that order, and some of them are *marked*.

We define, for each  $k$  such that  $1 \leq k \leq 2n + 1$ , the interval  $I_k$  to be the closed circular interval starting at  $k$  and ending at  $k + n$  (taking remainders modulo  $2n + 1$  if  $k + n > 2n + 1$ ). We call an interval  $I_k$  *magical* if it contains strictly more than half of all the marked elements.

Prove that the following two statements are equivalent:

1. At least  $n + 1$  of the intervals  $I_1, I_2, \dots, I_{2n+1}$  are magical.
2. The number of marked numbers is odd.

(Andrei Constantinescu)

**First Solution.** Let  $S$  be the set containing all the marked numbers and  $S_i = S \cap I_i$ . Note that  $S_i \cap S_{i+n} = \emptyset$  or  $\{i+n\}$ . So for each  $i$  we have that

$$|S_{i+n}| = \begin{cases} |S| - |S_i| + 1, & \text{if } i+n \in S \\ |S| - |S_i|, & \text{otherwise.} \end{cases}$$

2 points.

Suppose  $|S|$  is odd. For each interval,  $I_i$ , that isn't magical we have that  $|S_i| < \frac{|S|}{2}$  (since the equality can't hold) hence  $|S_{i+n}| \geq |S| - |S_i| > |S| - \frac{|S|}{2} = \frac{|S|}{2}$  so  $I_{i+n}$  is magical. So for each non magical interval we can find a unique magical one, therefor we must have at least  $n + 1$  magical intervals.

4 points.

Now suppose  $|S|$  is even. For each magical interval  $I_i$ , we have that  $|S_i| > \frac{|S|}{2}$  hence  $|S_{i+n}| \leq |S| - |S_i| + 1 < |S| - \frac{|S|}{2} + 1 = \frac{|S|}{2} + 1 \implies |S_{i+n}| \leq \frac{|S|}{2}$  so  $I_{i+n}$  is not magical. Since for each magical interval we can find a unique non magical one, there must be at least  $n + 1$  non magical intervals, so less than  $n + 1$  magical ones.

4 points.

**Second Solution.** Represent the remainders modulo  $2k + 1$  in a circle in ascending order. For the rest of the solution, *t-good* means the interval  $[t, t + k]$  is magical, and the set being very good means it satisfies property (1). Label the vertices of the graph as  $(0, 1, 2, \dots, 2k)$ . If  $S$  is *t-good*, draw an edge between  $t$  and  $t + k$  (taken modulo  $2k + 1$ ). Now we prove both directions:

- Let  $|S| = 2l$  be **very good**. The critical observation is the following: there is a node with degree 2. Since  $S$  is **very good**, there are at least  $k + 1$  edges. Thus, the total sum of degrees is at least  $2k + 2$ .

1 point.

By the pigeonhole principle, there is a node with degree 2. Let  $a$  be the value of this node.

1 point.

By definition, the intervals  $[a, a + k]$  and  $[a - k, a]$  each contain more than half of the elements of  $S$ , i.e., at least  $l + 1$  elements each. These two intervals share exactly one element.

2 points.

Thus, the total number of distinct elements of  $S$  in these intervals is at least:

$$2l + 2 \quad (\text{if } a \notin S), \quad \text{or} \quad 2l + 1 \quad (\text{if } a \in S).$$

This contradicts  $|S| = 2l$ . Hence, if  $S$  is **very good**,  $S$  must have an odd number of elements.

1 point.

- Now let  $|S| = 2l - 1$ . A similar lemma applies: every node has degree at least 1. Fix a value  $x$ . The intervals  $[x - k, x]$  and  $[x, x + k]$  cover the entire residue class modulo  $2k + 1$  and share exactly one element. Now we split into two cases:
  - If  $x \in S$ , the remaining elements of  $S$  are in two disjoint intervals  $[x - k, x - 1]$  and  $[x + 1, x + k]$ . By the pigeonhole principle, one of these intervals contains at least  $l - 1$  elements. Adding  $x$  creates a good interval with one of its endpoints at  $x$ , so  $x$  has degree at least 1.
  - If  $x \notin S$ , the elements of  $S$  are in two disjoint intervals  $[x - k, x - 1]$  and  $[x + 1, x + k]$ . By the pigeonhole principle, one of these intervals contains at least  $l$  elements, so the conclusion is the same as above.

In either case,  $x$  has degree at least 1.

3 points.

Similarly, every node has degree at least 1, so the total sum of degrees is at least  $2k + 1$ . By the handshake lemma, the total sum of degrees is at least  $2k + 2$ . This gives at least  $k + 1$  edges. Thus,  $S$  is indeed **very good**.

2 points.

**Problem 3.** Let  $\omega$  be a semicircle with diameter  $\overline{AB}$  and let  $M$  be the midpoint of  $\overline{AB}$ . Let  $X, Y$  be the points in the same half-plane as  $\omega$  with respect to the line  $AB$  such that  $AMXY$  is a parallelogram. Let  $I$  be the incenter of the triangle  $MXY$ . Lines  $MX, MY$  intersect  $\omega$  in points  $C, D$  respectively. Let  $T$  be the intersection of  $AC$  and  $BD$ . The line  $MT$  intersects  $XY$  in  $E$ . If  $P$  is the intersection of  $EI$  and  $AB$ , and  $Q$  is the projection of  $E$  onto the line  $AB$ , show that  $M$  is the midpoint of  $\overline{PQ}$ .

(Michal Pecho)

**Solution.** We will work in the context of a triangle  $MXY$ . The solution is in two parts:

**Claim 2.**  $E$  is the  $M$ -excircle touch point with  $XY$

We present two proofs:

*Proof.* We first claim that  $TCD$  is tangent to both  $MX$  and  $MY$ . Observe:

$$\angle MCT = \angle MCA = \angle CAM = \angle CAB = \angle CDB = \angle CDT$$

where the angles are directed. This shows that  $MX$  is tangent to  $CDT$ . Analogous proof gives  $MY$  tangent to  $CDT$ .

**2 points.**

Now we claim that the tangent to  $CDT$  at  $T$  is parallel to  $XY$ . The cleanest way is through negative inversion in  $T$  fixing the circle with diameter  $AB$ . This sends  $(CDT)$  into  $AB$  and fixes the tangent. The tangency is preserved, so the two lines are parallel, as desired.

**1 point.**

If the mentioned tangent meets  $MX$  and  $MY$  at  $R, S$  respectively, we have shown that  $CDT$  is  $M$ -excircle in  $MRS$ . Consider the homothety centred at  $M$  that maps  $RS$  to  $XY$ . It also maps  $T$  into  $E$ , but it also sends the excircle of  $MRS$  into the excircle of  $MXY$ , hence sending the  $M$ -touchpoint in  $MRS$  (i.e.  $T$ ) into  $E$ , which is what we wanted to show.

**3 points.**

□

*Proof.* Let  $U, V$  be points of  $XY$  such that  $U, X, Y, V$  lie on  $XY$  in that order, and  $UX = XM, VY = YM$ . Also let  $R, S$  be the intersections of  $XY$  with  $AC, BD$  respectively (note that these do not correspond to  $R, S$  in the previous proof). Easy angle chase gives:

$$\begin{aligned} \angle YRT &= \angle XRC = \angle MXY - \angle MCA \\ &= \angle BMC - \angle MCA \\ &= \frac{1}{2} \angle YXM \\ &= \angle XUM \end{aligned}$$

, so  $MU \parallel TR$ . Similarly  $MV \parallel TS$ . Now the triangles  $TRS$  and  $MUV$  are homothetic

**4 points.**

, with  $E$  being the homothety center. The idea is that we can now express all the relevant lengths in terms of  $MXY$ . Let  $a = XY, b = YM, c = MX$ . Compute:

$$\begin{aligned} XR &= XC = a - c \\ YS &= YD = a - b \\ RS &= XY - XR - SY = b + c - a \end{aligned}$$

From Thales,

$$\frac{ER}{ES} = \frac{RU}{SV} = \frac{a}{a} = 1$$

and finally  $XE = XR + \frac{1}{2}RS = a - c + \frac{b+c-a}{2} = \frac{a+b-c}{2}$ , which is precisely the distance from  $X$  to  $M$ -extouchpoint.

**2 points.**

□

Having established that, let  $Z$  be the midpoint of  $M$ -altitude in  $MXY$  and  $N$  be its foot. It is well-known that  $Z, I, E$  are collinear, one can get that for example with homothety mapping the incircle to  $M$ -excircle

**2 points.**

. We are now done, check that  $PM = NE$  from congruent  $MPZ$  and  $ZNE$  and  $MQ = NE$  from the rectangle.

**2 points.**

**Problem 4.** Find all functions  $f: \mathbb{R}^+ \rightarrow \mathbb{R}^+$  such that

$$f(x + yf(x)) = xf(1 + y)$$

for all  $x, y \in \mathbb{R}^+$ .

*Remark.* We denote by  $\mathbb{R}^+$  the set of all positive real numbers.

(Ioannis Galamatis)

**First Solution.** The function  $f(x) = x$  for all  $x \in \mathbb{R}^+$  satisfies the condition, and we will show it is the only such function.

Firstly, note that if  $f(x) \neq 1$  and we have that either  $x > 1, f(x) < 1$  or  $x < 1, f(x) > 1$ , plugging in  $x$  and

$$y = \frac{1 - x}{f(x) - 1} > 0$$

gives that  $x = 1$ , a contradiction. Therefore, for all  $x < 1$  we have  $f(x) \leq 1$  and for all  $x > 1$  we have  $f(x) \geq 1$ .

**1 point.**

Now, assume that  $f(t) < t$  for some  $t \in \mathbb{R}^+$ , and take

$$x = f(t), y = \frac{t - f(t)}{f(f(t))}$$

in the starting equation. If we denote  $s = \frac{t - f(t)}{f(f(t))}$  this gives

$$f(t) = f(t)f(1 + s) \implies f(1 + s) = 1$$

as the left-hand side and the  $f(t)$  term on the right cancel out. If we now plug in

$$x = 1 + \frac{s}{2}, y = \frac{s}{2f(1 + \frac{s}{2})}$$

we obtain that

$$1 = f(1 + s) = \left(1 + \frac{s}{2}\right) \cdot f(1 + y) \geq 1 + \frac{s}{2}$$

which is a contradiction.

Therefore,  $f(x) \geq x$  for all  $x \in \mathbb{R}^+$ .

**2 points.**

If we apply this inequality to the left-hand side, we obtain that

$$xf(1 + y) \geq x + yf(x) \iff \frac{f(x)}{x} \leq \frac{f(y + 1) - 1}{y}$$

for all  $x, y \in \mathbb{R}^+$ . Plugging in  $y = 1$ , we obtain that  $f(x)/x$  is bounded by  $f(2) - 1$  for all  $x \in \mathbb{R}^+$ , and we already know it's always at least 1. Define

$$C = \limsup_{x \rightarrow \infty} \frac{f(x)}{x}.$$

We easily obtain that  $\frac{f(y') - 1}{y' - 1} \geq C$  for all  $y' = y + 1 \in \langle 1, \infty \rangle$ , which rearranges to  $f(y') \geq Cy' + 1 - C$  for all  $y' > 1$ . Additionally, by definition of  $C$ , for all  $\varepsilon > 0$  there exists some  $T_\varepsilon > 0$  such that  $x > T_\varepsilon \implies f(x) \leq (C + \varepsilon)x$ . Now, take some  $x, y > \max\{1, T_\varepsilon\}$  and notice that  $x + yf(x) > 1$  and  $y + 1 > T_\varepsilon$  implies that we have

$$Cx + C^2xy + (1 - C)(y + 1) \leq f(x + yf(x)) = xf(y + 1) \leq x(C + \varepsilon)(y + 1) = Cxy + Cx + \varepsilon xy + \varepsilon x$$

which rearranges to

$$(C^2 - C - \varepsilon)y \leq \frac{(C - 1)(y + 1)}{x} + \varepsilon$$

for all  $x, y$  large enough. By fixing  $y$  and taking  $x \rightarrow \infty$  we see that  $C^2 - C \leq \varepsilon + \frac{\varepsilon}{y} < 2\varepsilon$  and as  $\varepsilon$  was arbitrary, we have that  $C^2 - C = 0$  so  $C = 1$ .

**5 points.**

To finish, note that there now exists, for every  $\varepsilon > 0$ , a  $T_\varepsilon$  such that  $y + 1 > T_\varepsilon$  implies  $f(y + 1) \leq (1 + \varepsilon)(y + 1)$  and inserting this  $y$  into the inequality we earlier obtained gives that

$$\frac{f(x)}{x} \leq \frac{y + \varepsilon y + \varepsilon}{y} = (1 + \varepsilon) + \frac{\varepsilon}{y} < 1 + 2\varepsilon$$

for every  $x \in \mathbb{R}^+$  and as  $\varepsilon$  is arbitrary, we obtain  $f(x) \leq x$  for all  $x \in \mathbb{R}^+$  and we are done.

**2 points.**

**Second Solution.** We shall firstly prove the following lemma about the behavior of  $f$ .

**Lema 1.** *The function  $f$  is non-decreasing.*

*Proof.* Assume on the contrary, there are  $a > b$  such that  $f(a) < f(b)$ . Then,  $c = \frac{a-b}{f(b)-f(a)}$  is positive. Now, plugging  $(x, y) = (a, c)$  yields

$$f\left(\frac{af(b) - bf(a)}{f(b) - f(a)}\right) = f\left(a + \frac{a-b}{f(b)-f(a)}f(a)\right) = af(1+c)$$

Plugging  $(x, y) = (b, c)$  yields;

$$f\left(\frac{af(b) - bf(a)}{f(b) - f(a)}\right) = f\left(b + \frac{a-b}{f(b)-f(a)}f(b)\right) = bf(1+c)$$

Yielding,  $a = b$ , a contradiction. This completes our proof.

3 points.

□

Now, it is easy to find that  $f$  is *surjective*, indeed,  $f(x/f(2)) + f(x/f(2)) = x$ .

1 point.

Thus,  $f$  would be *continuous*<sup>1</sup>.

2 points.

Hence,  $f(x) = \lim_{y \rightarrow 0^+} f(x + yf(x)) = x \lim_{y \rightarrow 0^+} f(1 + y) = xf(1)$ .

3 points.

That is,  $f(x) = Cx$ , for some  $C > 0$ . Hence,  $C(x + C^2xy) = Cx(1 + y)$ , yielding  $C = 1$ . It is easy to verify that  $f(x) = x$  indeed satisfies the statement of the problem.

1 point.

**Third Solution.** For  $x > 1$  we have  $f(x) \geq 1$  otherwise plugging in  $y = \frac{1-x}{f(x)-1}$  gives us a contradiction.

Applying this to the *RHS* of the original equation we get  $f(x + yf(x)) \geq x$ .

Putting  $x = s - \epsilon, y = \frac{\epsilon}{f(s-\epsilon)}, \epsilon \rightarrow 0$  we get  $f(s) \geq s$  for all  $s \in \mathbb{R}^+$ .

3 points.

Applying this to the *LHS* of the original equation, yielding;

$$f(y + 1) \geq 1 + y \frac{f(x)}{x} \quad \forall x, y \in \mathbb{R}^+$$

1 point.

If there exist  $c > 1$  such that  $\frac{f(c)}{c} > 1$ . Put  $K = \frac{f(c)}{c}$ .

**Claim 3.**  $f(y + 1) \geq yK^n \quad \forall n \in \mathbb{N}, \forall y \in \mathbb{R}^+$ .

*Proof.* We shall prove it through induction. The base is clear. Putting  $(x, y) = (c, y)$  into original equation and assuming  $f(y + 1) \geq yK^n$  for all  $y$  and fixed  $n$ :

$$cf(y + 1) = f(c + yf(c)) \geq (c + yf(c) - 1)K^n \geq yf(c)K^n$$

gives us  $f(y + 1) \geq yK^n \implies f(y + 1) \geq yK^{n+1}$ .

4 points.

□

Back to our problem, fixing  $y$  and using the claim letting  $n \rightarrow \infty$  we get that such  $K$  can't exist, that is  $f(x) \leq x$  for  $x > 1$ . Since we already proved  $f(x) \geq x$  we have  $f(x) = x$  for  $x > 1$ , but returning to  $f(y + 1) = y + 1 \geq 1 + y \frac{f(x)}{x}$  gives us  $f(x) = x$  for all  $x$ . It is easy to check that  $f(x) = x$  indeed satisfies the original equation.

2 points.

---

<sup>1</sup>For sake of completeness, in the following we shall provide the *outline* of the proof of this claim: Since  $f$  is non-decreasing, for an arbitrary positive  $a$ ,  $\lim_{x \rightarrow a^-} f(x)$ ,  $\lim_{x \rightarrow a^+} f(x)$  exist and  $\lim_{x \rightarrow a^-} f(x) \leq \lim_{x \rightarrow a^+} f(x)$ . Now, we prove these two limits are equal. Assume for contradiction,  $b = \lim_{x \rightarrow a^-} f(x) < \lim_{x \rightarrow a^+} f(x) = c$ . Thus, for all  $x < a$  we have  $f(x) \leq b$ , for all  $x > a$ , we have  $f(x) \geq c$ . Hence the image of function is a subset of  $(0, b) \cup (c, +\infty) \cup \{f(a)\}$ . This, can not be the whole  $\mathbb{R}^+$ . The derived contradiction, completes our proof.



# Statistics of the 13th European Mathematical Cup

14th Dec 2024 - 22th Dec 2024



## Junior Category

#	J1	J2	J3	J4
0	206	378	448	532
1	31	23	13	2
2	114	11	21	11
3	9	13	2	0
4	8	9	1	0
5	16	2	0	0
6	21	2	1	0
7	8	3	0	0
8	16	2	2	1
9	17	4	1	2
10	104	103	61	2
$\Sigma$	550	550	550	550
$\mu$	3.46	2.26	1.28	0.13
$\sigma$	3.93	3.94	3.19	0.92

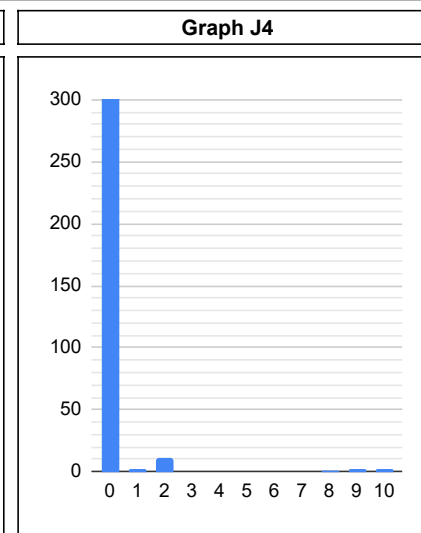
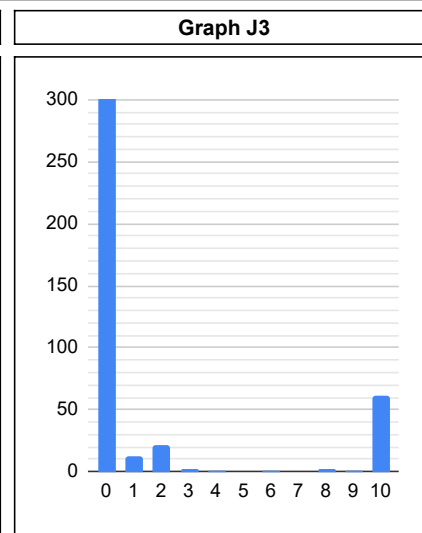
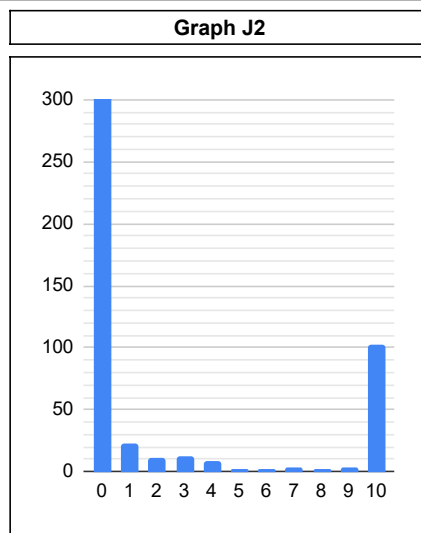
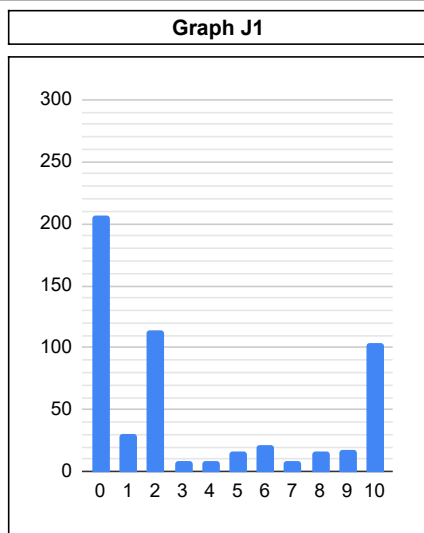

## Senior Category

#	S1	S2	S3	S4
0	147	197	320	250
1	34	8	13	89
2	59	6	10	9
3	22	1	1	20
4	24	7	2	3
5	3	6	1	4
6	6	7	1	3
7	9	3	0	2
8	10	13	0	2
9	1	5	3	5
10	83	145	47	11
$\Sigma$	398	398	398	398
$\mu$	3.38	4.38	1.39	1.01
$\sigma$	3.90	4.71	3.30	2.18

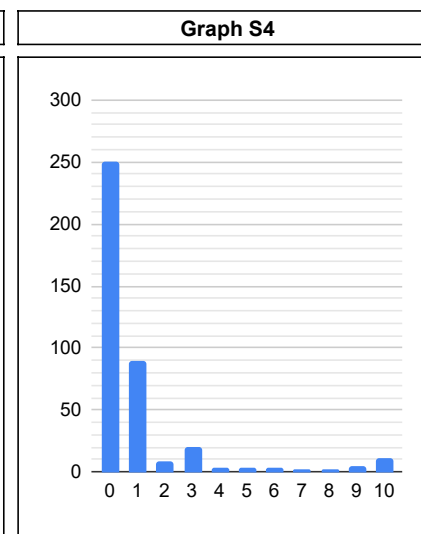
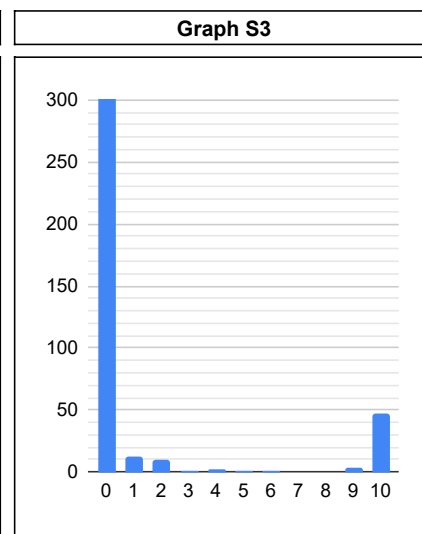
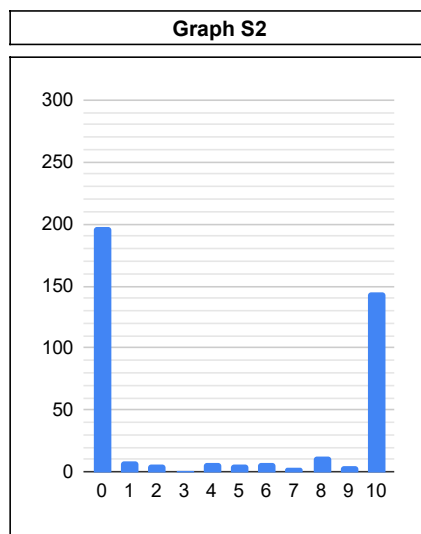
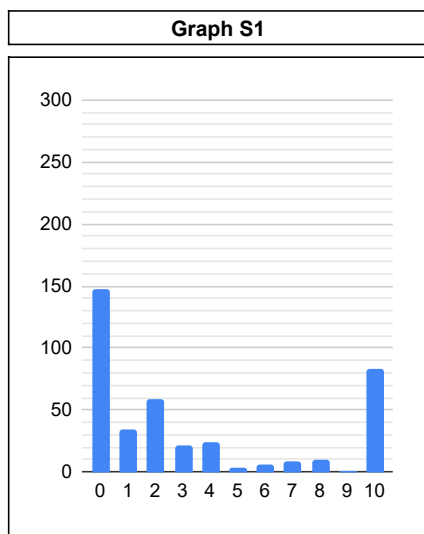



Enjoy solving complex problems using creative mathematical thinking? So do we!

Visit [www.janestreet.com](http://www.janestreet.com) to learn more about our educational programs, internships and full-time roles.

And of course - **Good Luck!**

Voliš rješavati teške probleme koristeći kreativno matematičko razmišljanje? I mi!

Posjeti [www.janestreet.com](http://www.janestreet.com) gdje možeš saznati više o edukacijama, stažiranjima i prilikama za zaposlenje.

I naravno - **Puno sreće!**

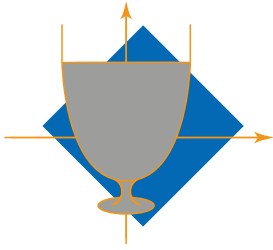

**14<sup>TH</sup> EUROPEAN MATHEMATICAL CUP**  
 13<sup>th</sup> December 2025 - 21<sup>st</sup> December 2025



Junior Category

**Problem 1.** Let  $\omega_1$  and  $\omega_2$  be two circles intersecting at  $A$  and  $B$ . The common tangent, closer to  $A$ , of  $\omega_1$  and  $\omega_2$  touches  $\omega_1$  at  $P$  and  $\omega_2$  at  $Q$ . The tangent of  $\omega_1$  at  $A$  meets  $\omega_2$  at  $C$ , which is different from  $A$ , and the extension of  $AP$  meets  $QC$  at  $D$ . Let  $E$  be the center of circumcircle of triangle  $ABD$ . The lines  $AD$  and  $QE$  intersect at  $F$ . Prove that  $F$  lies on the circle with diameter  $PQ$ .

(Steve Vo Dinh)

**Problem 2.** Let  $n$  be a positive integer. Divide an equilateral triangle of side length  $n$  into equilateral triangles of side length one. Here is an example shown below for  $n = 4$ :

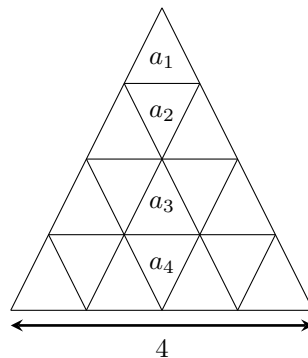

Label the small equilateral triangles through which one of the altitudes of the large equilateral triangle passes as  $a_1, a_2, \dots, a_n$  (see illustration above how to do in case of  $n = 4$ ).

Let  $f(i)$  denote the number of ways to tile the large equilateral triangle using exactly one of each

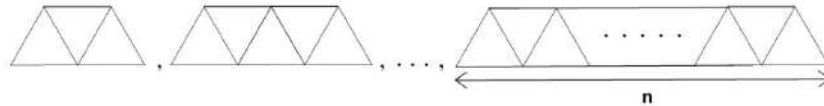

such that the triangle  $a_i$  is removed.

- If  $n$  is even, determine  $f(2) + f(4) + \dots + f(2k) + \dots + f(n)$ .
- Prove that  $f(1) + f(2) + \dots + f(n) \geq 2^{n-2}$ , for all positive integers  $n$ .

(Karlo Jokoš)

**Problem 3.** Determine the largest positive integer  $n$  for which there exist positive integers  $a$  and  $q$  such that

$$q^6 \leq n \quad \text{and} \quad \left| \sqrt{2} - \frac{a}{q} \right| \leq \frac{1}{\sqrt{n}}.$$

(Miroslav Marinov)

**Problem 4.** Find all positive integers  $n$  with the following property:

For every positive integer  $d$  which divides  $n$ , there exists a positive integer  $k$  which divides  $n$  such that

$$d + n \mid dn + k.$$

(Ivan Novak)

Time: 240 minutes.

Each problem is worth 10 points.

The use of calculators or any other instruments except rulers and compasses is not permitted.

Cheating in any form is strictly prohibited. Sharing or posting the problems or solutions before the end of the competition (22nd of December) to anyone who might participate is strictly prohibited.

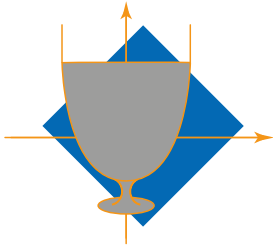

**PROBLEMS AND SOLUTIONS OF THE  
14<sup>TH</sup> EUROPEAN MATHEMATICAL CUP**  
13<sup>th</sup> December 2025 - 21<sup>th</sup> December 2025



Junior Category

**Problem 1.** Let  $\omega_1$  and  $\omega_2$  be two circles intersecting at  $A$  and  $B$ . The common tangent, closer to  $A$ , of  $\omega_1$  and  $\omega_2$  touches  $\omega_1$  at  $P$  and  $\omega_2$  at  $Q$ . The tangent of  $\omega_1$  at  $A$  meets  $\omega_2$  at  $C$ , which is different from  $A$ , and the extension of  $AP$  meets  $QC$  at  $D$ . Let  $E$  be the centre of the circumcircle of triangle  $ABD$ . The lines  $AD$  and  $QE$  intersect at  $F$ . Prove that  $F$  lies on the circle with diameter  $PQ$ .

*(Steve Vo Dinh)*

**Solution.** It suffices to show that  $\angle PFQ = 90^\circ$ . Since  $AE = DE$  (since  $E$  is the centre of the circumcircle of  $ABD$ ), this is equivalent to  $QE$  being the perpendicular bisector of  $\overline{AD}$ , since we know that all points on the perpendicular bisector are equidistant from the endpoints of  $\overline{AD}$ . So, it is sufficient to prove  $QA = QD$ , and with this, we completely remove  $E$  from the diagram.

**3 points.**

For convenience, denote  $\angle AQP = \alpha$ ,  $\angle APQ = \beta$ . Then:

$$\angle QAD = \alpha + \beta$$

from triangle  $APQ$  (since the exterior angle is equal to the sum of the two remaining interior angles).

**1 point.**

It remains to compute  $\angle QDA = \angle ACD + \angle DAC$ . We have

$$\angle ACD = \angle ACQ = \angle AQP = \alpha$$

from the tangent  $QP$  to  $\omega_2$  (by the Chord Tangent Lemma, also known as the Alternate Segment Theorem)

**1 point.**

On the other hand,  $\angle DAC = 180^\circ - \angle PAC$  since  $P$ ,  $A$  and  $D$  lie on the same line. However, since  $AC$  is tangent to  $\omega_1$ , we can find  $\angle CAB = \angle APB$  (again by the Chord Tangent Lemma).

Now, we can break the  $180^\circ = \angle PAD = \angle PAB + \angle BAC + \angle CAD$  around point  $A$ , but we can also find the sum of internal angles in  $APB$  to be  $\angle PAB + \angle BPA + \angle ABP = 180^\circ$ , so by previous conclusion, we get that  $\angle ABP = \angle CAD$ .

**3 points.**

Lastly,  $\angle ABP = \angle APQ = \beta$  since  $PQ$  is tangent to  $\omega_1$  (using the Chord Tangent Lemma one last time).

By looking at triangle  $CDA$ , we conclude that  $\angle QDA = \angle ACD + \angle DAC$ , so we have

$$\angle QDA = \angle ACD + \angle DAC = \alpha + \beta = \angle AQP + \angle APQ = \angle QAD$$

concluding  $QA = QD$ , as desired.

**2 points.**

**Problem 2.** Let  $n$  be a positive integer. Divide an equilateral triangle of side length  $n$  into equilateral triangles of side length one. (example shown below for  $n = 4$ ):

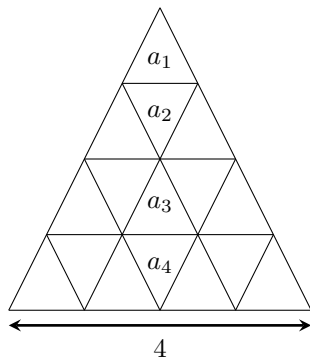

Label the small equilateral triangles through which one of the altitudes of the large equilateral triangle passes as  $a_1, a_2, \dots, a_n$  (see illustration above).

Let  $f(i)$  denote the number of ways to tile the large equilateral triangle using exactly one of each

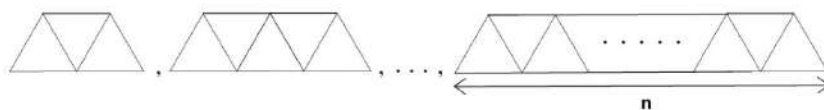

such that the triangle  $a_i$  is removed.

- If  $n$  is even, determine  $f(2) + f(4) + \dots + f(2k) + \dots + f(n)$ .
- Prove that  $f(1) + f(2) + \dots + f(n) \geq 2^{n-2}$ , for all positive integers  $n$ .

(Karlo Jokiš)

**First Solution. First Part**

Suppose there is a tiling with triangle  $a_{2k}$  missing, we tile the triangle starting with the largest tile, we can put it at three places (left, right or down), and we are left with a triangle of side length  $n - 1$ . We repeat that step repeatedly, choosing to put the tile left, right or down, until we are left with the triangle  $a_{2k}$ . But then we had to choose down  $n - 2k$  times, and left and right both the same number of times, so  $\frac{n-1-(n-2k)}{2} = \frac{2k-1}{2} \notin \mathbb{N}$ , which is impossible, hence  $f(2k) = 0$  and the sum is 0.

**Alternative proof of first part**

Colour all the triangles pointing upward black and the others white. The full triangle has  $n$  more black triangles than white triangles. Each of the  $n - 1$  shapes we are filling the big triangle with has one more black than white triangles, so the last unfilled triangle must be black. This is not the case for even numbers, so  $f(2k) = 0$  and the sum is 0.

*Regardless of the way the student have proved the first part, they should be awarded 4 points.*

**Second Part**

Let  $S_n$  be the sum we are bounding, and assume that the inequality holds for  $1, 2, \dots, n$ .

Let us prove the  $n + 1$  case, there are three places where we can put the largest tile, at the bottom of the big triangle, to the left or to the right.

In the first case there are  $S_n$  ways to tile the rest of the triangle, in the second case if we put the second largest tile on the right, we end up with a triangle of side length  $n - 1$  so there are at least  $S_{n-1}$  ways to tile the triangle in that case, and the same bound holds for the case where the largest tile is to the right. So we have  $S_{n+1} \geq S_n + 2S_{n-1} \geq 2^{n-2} + 2 \cdot 2^{n-3} = 2^{n-1}$ . So we have to check the base case for  $n = 1, 2$  and we get

$$S_1 = 1 \geq \frac{1}{2}, \quad S_2 = 1 \geq 1$$

**6 points.**

**Second Solution.** Suppose there is a tiling with triangle  $a_k$  missing, we tile the triangle starting with the largest tile, we can put it at three places (left, right or down) and we are left with a triangle of side length  $n - 1$ . We repeat that step repeatedly, choosing to put the tile left, right or down, until we are left with the triangle  $a_k$ . But then we had to choose down  $n - k$  times, and left and right both the same number of times so  $\frac{n-1-(n-k)}{2} = \frac{k-1}{2}$ . So we count the number of  $n - 1$ -tuples with entries from {down, left, right}, such that there are  $n - k$  downs, and  $\frac{k-1}{2}$  lefts and rights. So  $f(k) = \binom{n-1}{n-k} \binom{\frac{k-1}{2}}{\frac{k-1}{2}}$

**6 points.**

**First Part**

For even  $k$  we get that  $f(k) = 0$  so if  $n$  is even the sum over the even numbers is 0.

**1 point.**

**Second Part**

The sum is equal to

$$\sum_{k \text{ odd}} \binom{n-1}{n-k} \binom{\frac{k-1}{2}}{\frac{k-1}{2}} \geq \sum_{k \text{ odd}} \binom{n-1}{n-k} = \frac{1}{2} \sum \binom{n-1}{n-k} = 2^{n-2}$$

**3 points.**

**Problem 3.** Determine the largest positive integer  $n$  for which there exist positive integers  $a$  and  $q$  such that

$$q^6 \leq n \quad \text{and} \quad \left| \sqrt{2} - \frac{a}{q} \right| \leq \frac{1}{\sqrt{n}}.$$

(Miroslav Marinov)

**First Solution.** Assume  $q \geq 2$ . Then

$$\left| \sqrt{2} - \frac{a}{q} \right| \leq \frac{1}{\sqrt{n}} \leq \frac{1}{q^3} \leq \frac{1}{8}.$$

In particular,

$$\frac{a}{q} \leq \sqrt{2} + \frac{1}{8},$$

so

$$\sqrt{2} + \frac{a}{q} \leq 2\sqrt{2} + \frac{1}{8} < 3.$$

On the other hand, using the fact that  $|2q^2 - a^2| \geq 1$  (since  $\sqrt{2}$  is irrational and hence  $2q^2 - a^2 \neq 0$ ), we obtain

$$\frac{1}{q^2} \leq \frac{|2q^2 - a^2|}{q^2} = \left| \sqrt{2} - \frac{a}{q} \right| \left| \sqrt{2} + \frac{a}{q} \right| < \frac{3}{q^3}.$$

Therefore  $q < 3$ . Since  $q$  is a positive integer, it remains to consider only  $q = 1$  and  $q = 2$ .

**Case 1:**  $q = 1$ . We would need

$$\left| \sqrt{2} - a \right| \leq \frac{1}{8}.$$

However, since  $1.4 < \sqrt{2} < 1.5$ , the distance from  $\sqrt{2}$  to the nearest integer is greater than 0.4, which is larger than  $1/8$ . (Alternatively, we can proceed directly to  $q = 2$  by arguing that if we find a possible  $n$  with  $q = 2$ , then the case  $q = 1$  is automatically covered by the case  $q = 2$ , since any integer can be written as a fraction with denominator 2.)

**Case 2:**  $q = 2$ . For  $n \geq 2^6$  we must have

$$\left| \sqrt{2} - \frac{a}{2} \right| \leq \frac{1}{8}.$$

If  $a \neq 3$ , then

$$\left| \sqrt{2} - \frac{a}{2} \right| \geq \left| \sqrt{2} - 1 \right| > \frac{1}{8},$$

so the only possible value is  $a = 3$ .

**7 points.**

It remains to compute the largest  $n$  such that

$$\left| \sqrt{2} - \frac{3}{2} \right| \leq \frac{1}{\sqrt{n}}.$$

Equivalently,

$$n \leq \frac{1}{\left(\frac{3}{2} - \sqrt{2}\right)^2} = \left(\frac{3}{2} + \sqrt{2}\right)^2 = 68 + 48\sqrt{2}.$$

Since  $68 + 48\sqrt{2} < 136$  and  $68 + 48\sqrt{2} > 135$ , the largest possible integer value is

$$\boxed{135}.$$

**3 points.**

**Second Solution. (Alternative proof of  $q \leq 2$ )**

We will find the largest integer  $n$  when  $q \leq 2$  in the same order as in the first solution.

**3 points.**

We have

$$\begin{aligned} \left| \sqrt{2} - \frac{a}{q} \right| &\leq \frac{1}{n} \leq \frac{1}{q^3} \\ \implies |\sqrt{2}q^3 - aq^2| &\leq 1 \\ \implies \sqrt{2}q - \frac{1}{q^2} &\leq a \leq \sqrt{2}q + \frac{1}{q^2} \end{aligned}$$

Squaring gives

$$2q^2 - \frac{2\sqrt{2}}{q} + \frac{1}{q^4} \leq a^2 \leq 2q^2 + \frac{2\sqrt{2}}{q} + \frac{1}{q^4}$$

Now assume for contradiction that  $q \geq 3$  and notice that we have  $\frac{2\sqrt{2}}{q} - \frac{1}{q^4} < \frac{2\sqrt{2}}{q} + \frac{1}{q^4} \leq \frac{2\sqrt{2}}{3} + \frac{1}{81} < \frac{29}{30} + \frac{1}{30} = 1$ . Hence  $2q^2 - 1 < a^2 < 2q^2 + 1$ . Since  $a$  and  $q$  are integers, we must have  $a^2 = 2q^2$ , but this is impossible, as  $\sqrt{2}$  is irrational.

**7 points.**

**Problem 4.** Find all positive integers  $n$  with the following property:  
 For every positive integer  $d$  which divides  $n$ , there exists a positive integer  $k$  which divides  $n$  such that

$$d + n \mid dn + k.$$

(Ivan Novak)

**Solution.** Note that  $n = 1$  is obviously a solution. Now consider  $n > 1$ .

Taking  $d = n$  yields  $2n \mid n^2 + k$ , which gives us  $k = n$  and  $2n \mid n^2 + n$ , which implies that  $n$  must be odd.

We'll now prove that  $n$  must be a prime power.

Note that  $d \mid d + n$  for any divisor  $d$  of  $n$ , so if  $d + n \mid dn + k$ , it follows that  $d \mid k$ .

We can rewrite the condition as

$$1 + \frac{n}{d} \mid n + \frac{k}{d}.$$

Now note that  $n \equiv -d \pmod{1 + \frac{n}{d}}$ , so the condition is equivalent to

$$1 + \frac{n}{d} \mid \frac{k}{d} - d.$$

If  $\frac{n}{d} \geq d$ , then  $|\frac{k}{d} - d| \leq \frac{n}{d} < 1 + \frac{n}{d}$ , so we must have  $\frac{k}{d} = d$ , or  $k = d^2$ .

This means that for any divisor  $d \leq \sqrt{n}$  of  $n$ ,  $d^2$  also divides  $n$ .

**2 points.**

Now suppose that  $n$  is not a power of a prime. Let  $n = ab$  with  $a > b$  coprime and greater than 1. Then  $b^2$  divides  $n = ab$ , but then  $b$  divides  $a$ , a contradiction. Thus,  $n$  is a power of a prime.

**1 point.**

Let  $n = p^m$  for some positive integer  $m$ .

Let  $d = p^j$  with  $m \geq j > \frac{m}{2}$ . Then there exists  $p^\ell$  with  $j \leq \ell \leq m$  such that

$$p^j + p^m \mid p^{m+j} + p^\ell,$$

which is equivalent to

$$p^{m-j} + 1 \mid p^{m-\ell+j} + 1.$$

Recall the well known fact that if  $a \geq 2$ ,  $x$  and  $y$  are positive integers such that  $a^x + 1$  divides  $a^y + 1$ , then  $\frac{y}{x}$  is an odd integer. Hence  $m - \ell + j$  must be an odd number times  $m - j$ , i.e. there exists a nonnegative integer  $r$  with

$$m - \ell + j = (2r + 1)(m - j),$$

or equivalently

$$2r(m - j) = 2j - \ell \leq j.$$

Now take  $j = \lfloor m/2 \rfloor + 1$ . We get  $2r(\lfloor m/2 \rfloor - 1) = 2\lfloor m/2 \rfloor + 2 - \ell$ . For  $r = 0$  this doesn't work as then we'd have  $\ell > m$ .

For  $r > 0$  the left hand side is at least  $m - 2$ , and the right hand side is at most  $m/2 + 1$ , so we have  $m - 2 \leq m/2 + 1$ , or  $m \leq 6$ .

**4 points.**

For  $m = 5$ , we must have

$$2r(5 - j) = 2j - \ell.$$

Take  $j = 3$ . We get  $4r = 6 - \ell \leq 3$ , impossible. Thus,  $m = 5$  is also not a solution.

**1 point.**

For  $m \in \{1, 2, 3, 4, 6\}$ , we can easily check that for any  $j > m/2$  we can find  $r$  and  $\ell$  satisfying the condition

$$2r(m - j) = 2j - \ell.$$

Thus, the set of solutions is

$$\{p^m \mid p \text{ an odd prime, } m \in \{0, 1, 2, 3, 4, 6\}\}.$$

**2 points.**

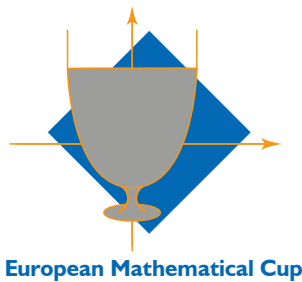

Enjoy solving complex problems using creative mathematical thinking? So do we!

Visit [www.janestreet.com](http://www.janestreet.com) to learn more about our educational programs, internships and full-time roles.

And of course - **Good Luck!**

Voliš rješavati teške probleme koristeći kreativno matematičko razmišljanje? I mi!

Posjeti [www.janestreet.com](http://www.janestreet.com) gdje možeš saznati više o edukacijama, stažiranjima i prilikama za zaposlenje.

I naravno - **Puno sreće!**

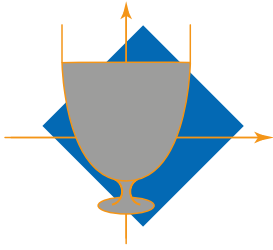

14<sup>TH</sup> EUROPEAN MATHEMATICAL CUP  
13<sup>th</sup> December 2025 - 21<sup>st</sup> December 2025



Senior Category

**Problem 1.** Let  $k \geq 2$  be an integer. Let  $m$  and  $n$  be coprime positive integers with exactly  $k$  positive divisors such that  $m < n$ .

For  $i \in \{1, \dots, k\}$ , denote by  $f_i$  and  $d_i$  the  $i$ -th smallest divisor of  $m$  and  $n$ , respectively. Suppose that

$$d_i - f_i \mid n - m$$

for all  $i \in \{2, \dots, k\}$ . Prove that  $d_i \geq f_i$  for all  $i \leq \frac{k}{2}$ .

(Ivan Novak)

**Problem 2.** Let  $f: \mathbb{N} \rightarrow \mathbb{N}$  (where  $\mathbb{N}$  is a set of positive integers) be a function such that for every positive integer  $k$ , the set  $\{f(1), f(2), \dots, f(k)\}$  contains exactly  $f(f(k))$  elements. Prove that

$$f(f(f(k))) = f(k)$$

for every positive integer  $k$ .

(Ivan Novak)

**Problem 3.** Let  $ABC$  be an acute triangle with circumcircle  $\omega$ . Let the angle bisector of  $\angle B$  intersect  $AC$ ,  $\omega$ , and the parallel to  $AB$  from  $C$  in  $D$ ,  $E$  and  $F$  respectively. Let  $X$  be the intersection of  $\omega$  and the circumcircle of triangle  $DCF$ , and let  $Y$  be a point on  $CF$  such that  $YF = YD$ . The line  $XF$  intersects  $\omega$  and  $DY$  in  $T$  and  $P$  respectively. The circumcircle of triangle  $\triangle TDE$  meets the lines  $PF$  and  $EY$  in  $R$  and  $S$ . Prove that the circumcircles of triangles  $\triangle PRS$  and  $\triangle BDC$  are internally tangent.

(Yasser Merabet)

**Problem 4.** Determine all sequences of positive real numbers  $a_1, a_2, a_3, \dots$ , such that for each positive integer  $n$  the following equality holds:

$$a_n + \max(a_{n+1}, a_{n+2}) = \frac{1}{\min(a_n, a_{n+1})}.$$

(Ivan Novak)

Time: 240 minutes.

Each problem is worth 10 points.

The use of calculators or any other instruments except rulers and compasses is not permitted.

Cheating in any form is strictly prohibited. Sharing or posting the problems or solutions before the end of the competition (22nd of December) to anyone who might participate is strictly prohibited.

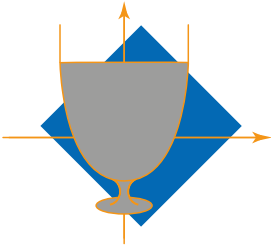

**PROBLEMS AND SOLUTIONS OF THE  
14<sup>TH</sup> EUROPEAN MATHEMATICAL CUP**  
13<sup>th</sup> December 2025 - 21<sup>th</sup> December 2025



Senior Category

**Problem 1.** Let  $k \geq 2$  be an integer. Let  $m$  and  $n$  be coprime positive integers with exactly  $k$  positive divisors such that  $m < n$ .

For  $i \in \{1, \dots, k\}$ , denote by  $f_i$  and  $d_i$  the  $i$ -th smallest divisor of  $m$  and  $n$ , respectively. Suppose that

$$d_i - f_i \mid n - m$$

for all  $i \in \{2, \dots, k\}$ . Prove that  $d_i \geq f_i$  for all  $i \leq \frac{k}{2}$ .

(Ivan Novak)

**First Solution.** We have by the condition of the problem:

$$f_1 < f_2 < \dots < f_k \quad \text{and} \quad d_1 < d_2 < \dots < d_k$$

Pairing up the divisors, we get:

$$n = d_{k+1-j}d_j \quad \text{and} \quad m = f_{k+1-j}f_j, \quad \forall j \in \{1, 2, \dots, k\}$$

**1 point.**

Suppose for the sake of contradiction that there is  $i \leq \frac{k}{2}$  such that  $d_i < f_i$ . So, we have:

$$j = k + 1 - i \geq k + 1 - \frac{k}{2} \geq \frac{k}{2} + 1 \geq 2$$

The last inequality implies  $f_i < f_j$  and  $d_j > f_j$ , otherwise  $m > n$  which is impossible.

**1 point.**

Setting  $a = f_i - d_i$  and  $b = d_j - f_j$ , we see that both  $a$  and  $b$  are positive integers and by the condition of the problem we have:

$$a \mid n - m \quad \text{and} \quad b \mid n - m$$

We have now:  $n - m = d_i d_j - f_i f_j = (d_i - f_i)d_j + (d_j - f_j)f_i = -ad_j + bf_i$ . The last equation gives:

$$a \mid f_i b \quad \text{and} \quad b \mid d_j a$$

**3 points.**

But since  $\gcd(m, n) = 1$ , then we get:

$$1 = \gcd(f_i, d_j) = \gcd(f_i, f_i - d_j) = \gcd(f_i, a)$$

**1 point.**

We deduce that  $a$  divides  $b$  and by symmetry that  $b$  divides  $a$ , hence  $a = b$ .

**1 point.**

Returning to the initial equation and plugging this result gives:

$$n - m = a(f_i - d_j) = a(f_i - f_j - a)$$

But  $a(f_i - f_j - a) < 0$  because  $f_i - f_j \leq 0$  and  $a > 0$ , so  $n - m < 0$  which is a contradiction, thus such  $i$  does not exist which solves the problem. ■

**3 points.**

**Second Solution.** For the sake of contradiction, suppose  $f_i > d_i$  for some  $i \leq \frac{k}{2}$ . Then, since

$$n = d_i \cdot d_{k+1-i} > f_i \cdot f_{k+1-i} = m$$

**1 point.**

we must have  $d_{k+1-i} > f_{k+1-i}$ .

**1 point.**

We notice that:

$$\begin{aligned} & d_i - f_i \mid n - m \\ \implies & d_i - f_i \mid n - m - \frac{n}{d_i} \cdot (d_i - f_i) \\ \implies & d_i - f_i \mid \frac{n \cdot f_i}{d_i} - \frac{m \cdot f_i}{f_i} \\ \implies & d_i - f_i \mid \frac{n}{d_i} - \frac{m}{f_i} \\ \implies & d_i - f_i \mid d_{k+1-i} - f_{k+1-i} \end{aligned}$$

**4 points.**

This gives us

$$d_i - f_i \mid d_{k+1-i} - f_{k+1-i} \quad \text{and} \quad d_{k+1-i} - f_{k+1-i} \mid d_i - f_i \quad (\text{in a similar way})$$

**1 point.**

From which we deduce that

$$f_i - d_i = d_{k+1-i} - f_{k+1-i} \iff \frac{n}{d_i} + d_i = \frac{m}{f_i} + f_i$$

Now since  $n > m$  we have:

$$\frac{n}{d_i} + d_i > \frac{m}{d_i} + d_i$$

And from  $(a+b)^2 = (a-b)^2 + 4ab$  and noting that since we supposed  $d_i < f_i$  we have  $\frac{m}{d_i} - d_i > \frac{m}{f_i} - f_i$  we have:

$$\frac{m}{f_i} + f_i < \frac{m}{d_i} + d_i$$

The last two inequalities give us:

$$\frac{m}{d_i} + d_i < \frac{n}{d_i} + d_i = \frac{m}{f_i} + f_i < \frac{m}{d_i} + d_i$$

which is a contradiction. ■

**3 points.**

**Problem 2.** Let  $f: \mathbb{N} \rightarrow \mathbb{N}$  be a function such that for every positive integer  $k$ , the set  $\{f(1), f(2), \dots, f(k)\}$  contains exactly  $f(f(k))$  elements. Prove that

$$f(f(f(k))) = f(k)$$

for every positive integer  $k$ .

(Ivan Novak)

**First Solution.** Note that  $f \circ f$  is increasing and  $f(f(n+1)) - f(f(n)) \leq 1$  for all  $n \geq 1$ .

**1 point.**

Therefore, the image of  $f \circ f$  is either the whole of  $\mathbb{N}$ , or a set of the form  $\{1, 2, \dots, a\}$  for some  $a \geq 1$ .

If the image is the whole of  $\mathbb{N}$ , let  $a_1, a_2, \dots$  be a sequence such that  $a_i$  is the smallest positive integer satisfying  $f(f(a_i)) = i$ . Note that the image of  $f$  is also  $\mathbb{N}$ . Also, if  $f(x)$  is distinct from  $f(1), f(2), \dots, f(x-1)$ , then  $f(f(x)) > f(f(x-1))$ . This means that  $x$  is an element of the sequence  $a_1, a_2, \dots$ . From this we can conclude that the image of  $f$  is equal to  $\{f(a_1), f(a_2), \dots\}$ .

Now for any  $x \in \mathbb{N}$ , if  $f(a_j) = x$  for some  $j$ , we must have  $f(x) = j$ . Hence, if  $f(x) = f(y) = j$  for some positive integers  $j, y$  and  $x$ , we must also have  $f(a_j) = x = y$ . Therefore,  $f$  is injective. Now it's easy to see that  $f(f(n)) = n$ , from which the claim follows.

**4 points.**

Suppose the image of  $f \circ f$  is equal to  $\{1, \dots, a\}$  for some  $a \geq 1$ . Then if the image of  $f$  contained more than  $a$  elements, taking the least  $n$  such that  $\{f(1), \dots, f(n)\}$  contains  $a+1$  elements would yield a contradiction. Hence, the image of  $f$  is equal to  $\{1, \dots, a\}$  as well. However, this means that

$$\{1, \dots, a\} = f(\mathbb{N}) = f(f(\mathbb{N})) = f(\{1, \dots, a\}),$$

which means that the restriction of  $f$  to the set  $\{1, \dots, a\}$  is a bijection. Now it's easy to see from the condition that  $f(f(j)) = j$  for all  $j \leq a$ . For any  $j > a$ , we must have  $f(f(j)) = a$  and  $f(j) \leq a$ . Hence,  $f(j)$  is the unique integer  $k \leq a$  such that  $f(k) = a$ . Then we have

$$f(f(f(j))) = f(a) = f(f(k)) = k = f(j),$$

which proves the claim.

**5 points.**

**Second Solution.** Like in previous solution we notice that  $0 \leq f(f(n+1)) - f(f(n)) \leq 1$ .

**1 point.**

Lemma 1:  $f(f(a)) = f(f(b)) \implies f(a) = f(b)$

Let  $k$  and  $l$  respectively be the smallest integers such that  $f(k) = f(a)$  and  $f(l) = f(b)$ . Then we have

$$f(f(k)) = f(f(a)) = f(f(b)) = f(f(l)).$$

**1 point.**

Now, if  $k > l$ , we have  $f(f(k)) > f(f(l))$  because  $f(k) \notin \{f(1), f(2), \dots, f(k-1)\}$  (we know that  $k-1$  exists since  $k > l$ ), so it must be that  $f(f(k)) > f(f(l))$ , and  $f \circ f$  is increasing. Similarly, we solve  $l > k$ . So we must have  $k = l$  which implies

$$f(a) = f(k) = f(l) = f(b).$$

**5 points.**

We do a proof by induction.

Base  $k = 1$ : It is obvious that  $f(f(1)) = 1$  from problem statement. So we have  $f(f(f(1))) = f(1)$ .

Assumption for all  $k \leq n$ : Assume that  $f(f(f(k))) = f(k)$ .

Step for  $k = n + 1$ : We will split this in 2 cases.

Case 1:  $f(f(n+1)) = f(f(n))$ .

Using the lemma, we have  $f(n+1) = f(n)$ . And then we have  $f(f(f(n+1))) = \underbrace{f(f(f(n)))}_{\text{Assumption}} = f(n) = f(n+1)$ .

**1 point.**

Case 2:  $f(f(n+1)) = f(f(n)) + 1$ .

If  $f(f(n)) = n$ , this is trivial since  $f(f(f(n+1))) = f(f(f(n)) + 1) = f(n+1)$ .

Assume that  $f(f(n)) < n$ . This implies  $f(f(n+1)) \leq n$  so we can use the assumption of induction for selecting  $k = f(f(n+1))$ , so we get  $f(f(f(f(f(n+1)))))) = f(f(f(n+1)))$ . Using the lemma twice, we get  $f(f(f(n+1))) = f(n+1)$ .

**2 points.**

**Third Solution.** Let  $n$  be the biggest integer such that  $f(f(n)) = n$  if it exists. Otherwise since we know  $f(f(1)) = 1$  it implies that it must hold for all  $n \in \mathbb{N}$  so we have  $f(f(f(k))) = f(k)$  for all  $k \in \mathbb{N}$ .

**1 point.**

By the fact that  $n$  is the biggest such integer, we must have  $f(f(n+1)) = f(f(n)) = n$  because, as in previous solutions, we have  $0 \leq f(f(n+1)) - f(f(n)) \leq 1$ .

**1 point.**

By the definition of  $n$  and the condition from problem we have  $f(f(i)) = i$  for all  $i \leq n$  this gives  $f(f(f(i))) = f(i)$  which means that  $f(i)$  is a fixed point of  $f \circ f$  and since  $n$  is the biggest fixed point of  $f \circ f$  by our definition we have  $f(i) \leq n$ .

**1 point.**

We will prove that  $f(m) = f(n)$  for all  $m > n$ . Assume that  $m > n$  is the first integer such that  $f(m) \neq f(n)$  this means that

$$f(n) = f(n+1) = \dots = f(m-1)$$

Case 1:  $f(f(m)) = f(f(n))$ .

We can proceed to prove it as in the **Lemma 1 of Second Solution** that we must have  $f(m) = f(n)$ . However, due to many more assumptions, easier proofs also work.

**3 points.**

Case 2:  $f(f(m)) = f(f(n)) + 1 = n + 1$  Considering  $f(f(f(m))) = f(n+1) \leq n < n+1 = f(f(m))$  we must have  $f(m) < m$ . But now we get

$$f(f(m)) \in \{f(1), f(2), \dots, f(m-1)\} = \{f(1), f(2), \dots, f(n)\}$$

. And since we know that all of those numbers are less than  $n$  (as we have proven). We get  $n+1 = f(f(n+m)) < n$ , which is a contradiction. ■

**4 points.**

**Problem 3.** Let  $ABC$  be an acute triangle with circumcircle  $\omega$ . Let the angle bisector of  $\angle B$  intersect  $AC$ ,  $\omega$ , and the parallel to  $AB$  from  $C$  in  $D$ ,  $E$  and  $F$  respectively. Let  $X$  be the intersection of  $\omega$  and the circumcircle of triangle  $\triangle DCF$  and let  $Y$  be a point on  $CF$  such that  $YF = YD$ . The line  $XF$  intersects  $\omega$  and  $DY$  in  $T$  and  $P$  respectively. The circumcircle of triangle  $\triangle TDE$  meets the lines  $PF$  and  $EY$  in  $R$  and  $S$ . Prove that the circumcircles of triangles  $\triangle PRS$  and  $\triangle BDC$  are internally tangent.

(Yasser Merabet)

**Solution.** Define the point  $R$  as the intersection of the circumcircle of triangle  $\triangle TDE$  with the line  $PF$ , and the point  $S$  as the intersection of the circumcircles of triangles  $\triangle TDE$  with the line  $EY$ . We will show that the circumcircles of triangles  $\triangle PRS$  and  $\triangle BDC$  are internally tangent which solves the problem. To do so, define the point  $Z$  as the intersection of the lines  $PB$  and  $CF$ .

Let  $\sphericalangle$  denote directed angles throughout this solution, (signed mod  $180^\circ$ ). The notation  $(AB)$  means the line which passes through the points  $A$  and  $B$  and the notation  $(ABC)$  means the circumcircle of triangle  $\triangle ABC$ .

Claim 1:  $(XB) \parallel (RD)$

Proof: We have:

$$\underbrace{\sphericalangle EDR = \sphericalangle ETR}_{RTDE \text{ cyclic}} = \underbrace{\sphericalangle ETX = \sphericalangle EBX}_{XTBE \text{ cyclic}}$$

Which proves claim 1.

2 points.

Claim 2:  $XDBP$  is cyclic

Proof: Note that:

$$\underbrace{\sphericalangle CBF = \sphericalangle FBA}_{BF \text{ is the angle bisector of } \sphericalangle CBA} \stackrel{(AB) \parallel (CF)}{=} \sphericalangle BFC \stackrel{YD \equiv YF}{=} \sphericalangle YDF$$

hence,  $(DY) \parallel (BC)$ . Now, in one hand, we have:

$$\begin{aligned} \sphericalangle DPX + \sphericalangle FYP + \sphericalangle PFY &= 0 \\ \sphericalangle DPX + \sphericalangle ABC + \sphericalangle PFY &= 0 \quad (DY) \parallel (BC) \end{aligned}$$

So, we get:

$$\sphericalangle DPX = \sphericalangle CBA + \sphericalangle YFP$$

(1)

In other hand, we have:

$$\begin{aligned} \sphericalangle CBA &= \sphericalangle DBX + \sphericalangle XBA + \sphericalangle CBE \\ &= \sphericalangle DBX + \sphericalangle XCA + \sphericalangle CBF \quad (ABCX \text{ is cyclic}) \\ &= \sphericalangle DBX + \sphericalangle XFD + \sphericalangle DFC \quad (DCFX \text{ is cyclic}) \\ &= \sphericalangle DBX + \sphericalangle XFC \\ &= \sphericalangle DBX + \sphericalangle PFY \end{aligned}$$

So, we get:

$$\sphericalangle DBX = \sphericalangle CBA + \sphericalangle YFP$$

(2)

Combining the two previous results ((1) and (2)), we deduce that the quadrilateral  $XDBP$  is cyclic.

2 points.

Notice that:

$$\sphericalangle DCZ = \sphericalangle DCF = \sphericalangle DXF = \sphericalangle DXP = \sphericalangle DBP = \sphericalangle DBZ$$

which implies  $DCZB$  is cyclic, so  $Z \in (BDC)$ . Now, we have to show that  $Z \in (PRY)$ .

1 point.

Claim 3:  $FRDZ$  is cyclic

Proof: We have:

$$\sphericalangle FRD = \sphericalangle PRD \stackrel{Claim 1}{=} \sphericalangle PXB \stackrel{Claim 2}{=} \sphericalangle PDB \stackrel{(DY) \parallel (BC)}{=} \sphericalangle CBD \stackrel{DCZB \text{ cyclic}}{=} \sphericalangle CZD = \sphericalangle FZD$$

which proves claim 3.

1 point.

Claim 4:  $ZPRY$  cyclic

Proof: We have:

$$\begin{aligned}\angle PRZ &= \angle PRD + \angle DRZ \\ &= \angle PXB + \angle DFZ \quad (\text{claim 1 and claim 3}) \\ &= \angle PDB + \angle DFY \quad (\text{claim 2}) \\ &= \angle YDF + \angle DFY \\ &= \angle FYD \\ &= \angle PYD\end{aligned}$$

which shows the desired claim.

**2 points.**

Before we finish, we show that  $S \in (PRY)$ . To do so, notice that:

$$\angle YSR = \angle ESR \stackrel{ETSR \text{ cyclic}}{=} \angle ETR \stackrel{EDTR \text{ cyclic}}{=} \angle EDR = \angle FDR \stackrel{\text{Claim 3}}{=} \angle FZR = \angle YZR \stackrel{\text{Claim 4}}{=} \angle YPR$$

Hence, we deduce that the points  $R, P, S$  and  $Y$  are concyclic and from what we did before, we find that the circumcircles of triangles  $\triangle PRS$  and  $\triangle BDC$  pass through the point  $Z$ .

**1 point.**

We finish the proof by taking the homothety centered at  $Z$  with ratio  $\frac{ZC}{ZY}$ , we get that  $C$  must be sent to  $Y$  and  $B$  must be sent to  $P$  (as  $(BC) \parallel (PY)$ ), but  $Z$  belongs to  $(DBC)$  and  $(PRY)$ , thus the circumcircles of triangles  $\triangle DBC$  and  $\triangle PRS$  are internally tangent which solves the problem. ■

**1 point.**

**Problem 4.** Determine all sequences of positive real numbers  $a_1, a_2, a_3, \dots$ , such that for each positive integer  $n$  the following equality holds:

$$a_n + \max(a_{n+1}, a_{n+2}) = \frac{1}{\min(a_n, a_{n+1})}.$$

(Ivan Novak)

**Solution.** The only constant sequence that is a solution is the sequence satisfying  $a_n = \frac{1}{\sqrt{2}}$  for all  $n$ . Also, one can easily check that any sequence which contains two consecutive elements equal to  $\frac{1}{\sqrt{2}}$  is constant. Now consider a nonconstant sequence  $(a_n)_n$  satisfying the conditions.

Now suppose that  $a_n \geq \frac{1}{\sqrt{2}}$  for some  $n$ . If  $a_{n+1} > \frac{1}{\sqrt{2}}$ , then the right hand side of the equality

$$a_n + \max(a_{n+1}, a_{n+2}) = \frac{1}{\min(a_n, a_{n+1})}$$

is at most  $\sqrt{2}$ , and the left hand side is greater than  $\sqrt{2}$ , which is a contradiction.

Thus, if  $a_n \geq \frac{1}{\sqrt{2}}$ , then  $a_{n+1} \leq \frac{1}{\sqrt{2}}$ .

Now suppose that  $a_{n+2} \geq \frac{1}{\sqrt{2}}$ . Then  $a_n + a_{n+2} = \frac{1}{a_{n+1}}$ . Furthermore, since  $a_{n+2} \geq \frac{1}{\sqrt{2}}$ , one has  $a_{n+3} \leq \frac{1}{\sqrt{2}}$  and from the recurrence for  $n+1$  one obtains

$$a_{n+1} + a_{n+2} = \frac{1}{a_{n+1}},$$

so  $a_n = a_{n+1} = \frac{1}{\sqrt{2}}$  and the sequence is constant, a contradiction.

We have thus proved that if  $a_n \geq \frac{1}{\sqrt{2}}$ , then  $a_{n+1} \leq \frac{1}{\sqrt{2}}$  and  $a_{n+2} \leq \frac{1}{\sqrt{2}}$ .

**1 point.**

Now suppose  $a_n, a_{n+1}, a_{n+2}$  are all  $\leq \frac{1}{\sqrt{2}}$ . Then the left hand side of the assertion is at most  $\sqrt{2}$ , and the right hand side is at least  $\sqrt{2}$ , with equality holding if  $a_n = \frac{1}{\sqrt{2}} = a_{n+1}$ , which would yield a constant sequence, a contradiction.

Thus, exactly every third element of the sequence is  $\geq \frac{1}{\sqrt{2}}$ , and the others are  $\leq \frac{1}{\sqrt{2}}$ .

Now if  $a_n = \frac{1}{\sqrt{2}}$  and  $a_{n+1} < \frac{1}{\sqrt{2}}$ , then the right hand side is greater than  $\sqrt{2}$ , and the left hand side is at most  $\sqrt{2}$ , a contradiction. Thus, we may also assume that  $\frac{1}{\sqrt{2}}$  does not occur in the sequence.

Now suppose  $a_n > \frac{1}{\sqrt{2}}$ . Then  $a_{n+3} > \frac{1}{\sqrt{2}}$ .

**2 points.**

If  $a_{n+1} < a_{n+2}$ , then from the assertion for  $n+1$  one has

$$a_{n+1} + a_{n+3} = \frac{1}{a_{n+1}},$$

and from the assertion for  $n+2$  one has

$$a_{n+2} + a_{n+3} = \frac{1}{a_{n+2}}.$$

From here, it follows that  $a_{n+1} = a_{n+2}$ , a contradiction.

If  $a_{n+1} > a_{n+2}$ , one has  $a_{n+1} + a_{n+3} = \frac{1}{a_{n+2}}$  and  $a_{n+2} + a_{n+3} = \frac{1}{a_{n+1}}$ , so  $a_{n+1} = a_{n+2}$ , a contradiction.

Thus,  $a_{n+1} = a_{n+2}$  whenever  $a_n > \frac{1}{\sqrt{2}}$ .

**2 points.**

Now we also have  $a_n + a_{n+1} = \frac{1}{a_{n+1}}$  and  $a_{n+2} + a_{n+3} = \frac{1}{a_{n+2}}$ , so  $a_n = a_{n+3}$  and the sequence is periodic with period 3, and of the form

$$(\dots, \frac{1}{x} - x, x, x, \dots)$$

for some  $x < \frac{1}{\sqrt{2}}$ , with possibly two initial members of the sequence being  $< \frac{1}{\sqrt{2}}$  not being equal to  $\frac{1}{x} - x$ .

Now suppose that  $a_n = \frac{1}{x} - x$ ,  $a_{n+1} = x$  for some  $x < \sqrt{2}$ , and suppose that  $a_{n-1}$  exists.

Then  $a_{n-1} + a_n = \frac{1}{a_{n-1}}$ , so  $a_{n-1} = x$ . This means that even the first part of the sequence is periodic.

**2 points.**

In conclusion, the answer is all periodic sequences of length 3 of the form

$$(\dots, \frac{1}{x} - x, x, x, \dots),$$

where  $x < \frac{1}{\sqrt{2}}$ , and the constant sequence  $a_n = \frac{1}{\sqrt{2}}$ .

**1 point.**

Now suppose  $a_n \leq \frac{1}{\sqrt{2}}$  and  $a_{n+1} > \frac{1}{\sqrt{2}}$ . Then  $a_{n+2} \leq \frac{1}{\sqrt{2}}$  and  $a_n + a_{n+1} = \frac{1}{a_n}$ .

Now suppose that  $a_n \leq \frac{1}{\sqrt{2}}$  and  $a_{n+1} \leq \frac{1}{\sqrt{2}}$ . Then the right hand side is at least  $\sqrt{2}$ , so  $\max(a_{n+1}, a_{n+2})$  is at least  $\frac{1}{\sqrt{2}}$ , which means that  $a_{n+2} \geq \frac{1}{\sqrt{2}}$ , or  $a_n = a_{n+1} = \frac{1}{\sqrt{2}}$  and  $a_{n+2} \leq \frac{1}{\sqrt{2}}$ .

**2 points.**



# Statistics of the 14th European Mathematical Cup

13th Dec 2025 - 21st Dec 2025



## Junior Category

#	J1	J2	J3	J4
0	439	503	687	674
1	27	47	17	21
2	8	17	10	25
3	32	13	20	18
4	1	93	1	2
5	5	14	1	7
6	1	10	1	1
7	5	8	2	3
8	2	5	5	2
9	8	6	4	2
10	238	50	18	11
$\Sigma$	766	766	766	766
$\mu$	3.49	1.66	0.50	0.44
$\sigma$	4.57	2.92	1.87	1.58

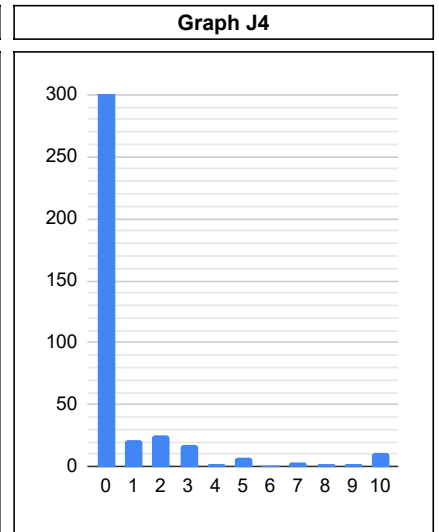
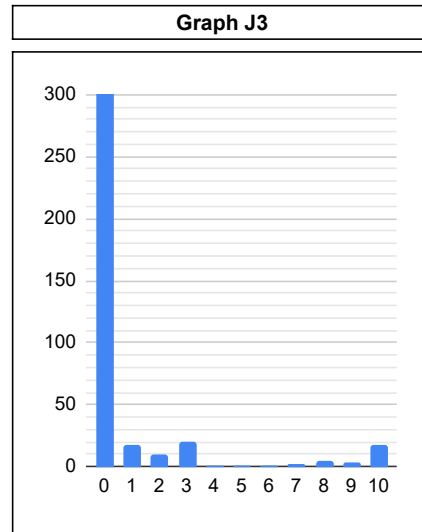
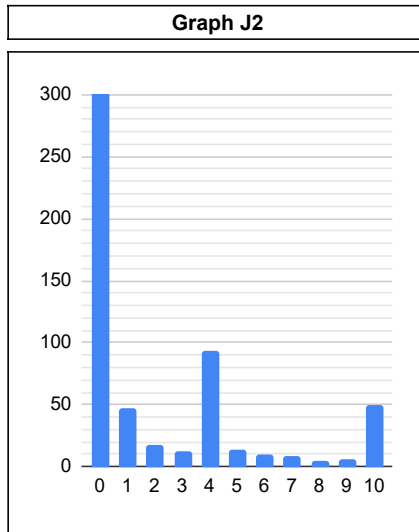
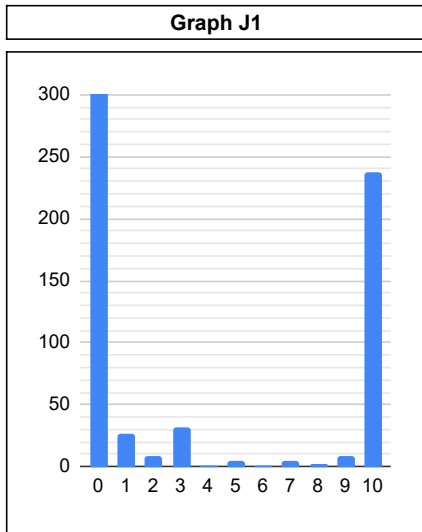

## Senior Category

#	S1	S2	S3	S4
0	233	294	470	521
1	64	49	28	5
2	4	26	11	1
3	1	17	7	1
4	10	7	4	2
5	13	12	0	0
6	19	9	3	0
7	25	9	1	2
8	2	13	0	0
9	2	11	0	3
10	169	95	18	7
$\Sigma$	542	542	542	542
$\mu$	4.05	2.79	0.54	0.24
$\sigma$	4.47	3.96	1.92	1.40

